

**CASTELO DE SONHOS PROJECT
PRE-FEASIBILITY STUDY**

**Castelo de Sonhos District, Pará State,
Brazil**

Prepared by GE21 Consultoria Mineral on behalf of:

TriStar Gold Inc.

Effective Date: October 4th, 2021

Author: Leonardo de Moraes Soares – MAIG

Author: Guilherme Gomides – MAIG

Author: Ricardo Reis de Paula – MAIG

Author: Porfirio Cabaleiro – FAIG

Author: Andries Jacobus Strauss – Pr.Eng. ECSA

Author: Martin Paul Boland – CGeol. GSL

Pre-Feasibility Study

Authors	Porfirio Cabaleiro Rodriguez	Mining Engineer	BSc (Mine Eng), FAIG
	Guilherme Gomides Ferreira	Mining Engineer	BSc (Mine Eng), MAIG
	Ricardo Reis de Paula	Mining Engineer	BSc (Mine Eng), MAIG
	Leonardo de Moraes Soares	Geologist	BSc (Geo.), MAIG
	Andries Jacobus Strauss	Civil Engineer	BSc (Civil Eng.), Pr.Eng. ECSA
	Martin Paul Boland	Geologist	PhD (Geo.), CGeol. GSL

Effective date: October 4th, 2021

Issue date: November 19th, 2021

GE21 Project nº: GE21- 210304

Version: Final

Work directory: S:\Projetos\TriStar\210304-PFS-CDS\23_Relatorio

Print date: 19th November, 2021

Copies:

TriStar Gold	(1)
GE21 Consultoria Mineral	(1)

Change Control

Version	Description	Authors	Date
Final			19/11/2021

<i>Original document signed and sealed.</i>	<i>Original document signed and sealed.</i>	<i>Original document signed and sealed.</i>
Porfirio Cabaleiro Rodriguez BSc (Mine Eng.), FAIG	Guilherme Gomides Ferreira BSc (Mine Eng.), MAIG	Ricardo Reis de Paula BSc (Mine Eng.), MAIG
<i>Original document signed and sealed.</i>	<i>Original document signed and sealed.</i>	<i>Original document signed and sealed.</i>
Leonardo de Moraes Soares BSc (Geo.), MAIG	Andries Jacobus Strauss BSc (Civil Eng.), Pr.Eng. ECSA	Martin Paul Boland PhD (Geo.), CGeol. GSL

Pre-Feasibility Study

Date and Signature

This report, entitled “CASTELO DE SONHOS PROJECT PRE-FEASIBILITY STUDY”, effective date October 4th, 2021, was prepared and signed by the following authors.

Dated in Belo Horizonte, Brazil, on November 19th, 2021.

Original document signed and sealed.

Porfirio Cabaleiro Rodriguez, BSc (Mine Eng.), FAIG

Original document signed and sealed.

Ricardo Reis de Paula, BSc (Mine Eng.), MAIG

Original document signed and sealed.

Guilherme Gomides Ferreira, BSc (Mine Eng.), MAIG

Original document signed and sealed.

Leonardo de Moraes Soares, BSc (Geo.), MAIG

Original document signed and sealed.

Andries Jacobus Strauss, BSc (Civil Eng.), Pr.Eng. ECSA

Original document signed and sealed.

Martin Paul Boland, PhD (Geo.), CGeol. GSL

Pre-Feasibility Study

IMPORTANT NOTICE

This report was prepared as National Instrument 43-101 Technical Report for TriStar Gold Inc. (TriStar) by GE21 Consultoria Mineral Ltda. (GE21) as part of a team of consultants contracted by TriStar. The quality of information, conclusions, and estimates contained herein is consistent with the level of effort involved in the report authors' services, based on i) information available at the time of preparation, ii) data supplied by outside sources, and iii) the assumptions, conditions, and qualifications set forth in this report. This report is intended for use by TriStar subject to terms and conditions of its individual contracts with the report authors and to the relevant securities legislation. The contracts between TriStar and the authors allow TriStar to file this report as a Technical Report with Canadian securities regulatory authorities, pursuant to National Instrument 43-101, Standards of Disclosure for Mineral Projects. Except for the purposed legislated under Canadian provincial and territorial securities law, any other use of this report by any third party is at that party's sole risk. The responsibility for this disclosure remains with TriStar. GE21 is under no obligation to update this Technical Report, except as may be agreed to between TriStar and GE21 by contract from time to time. The user of this document should ensure that this is the most recent Technical Report for the property as it is not valid if a new Technical Report has been issued.

Currency is expressed in U.S. dollars and metric units are used, unless otherwise stated.

© 2021 GE21 Consultoria Mineral Ltda.

This document, as a collective work of content and the coordination, arrangement and any enhancement of said content, is protected by copyright vested in GE21 Consultoria Mineral Ltda. Outside the purposes legislated under provincial securities laws or as otherwise stipulated in GE21's client contract, this document shall not be reproduced in full or in any edited, abridged or otherwise amended form unless expressly agreed in writing by GE21.

Pre-Feasibility Study

TABLE OF CONTENTS

1	EXECUTIVE SUMMARY	23
1.1	Qualified Persons, Experience, and Independence	23
1.2	Introduction	23
1.3	Reliance on Other Experts	23
1.4	Property Description and Location	23
1.5	Accessibility, Climate, Local Resources, Infrastructure, and Physiography	24
1.6	History	24
1.7	Geological Setting and Mineralization	24
1.8	Deposit Types	25
1.9	Exploration	25
1.10	Drilling	25
1.11	Sample Preparation, Analyses, and Security	26
1.12	Data Verification	26
1.13	Mineral Processing and Metallurgical Testing	27
1.14	Mineral Resource Estimates	27
1.15	Mineral Reserve Estimates	28
1.16	Mining Methods	29
1.17	Recovery Methods	30
1.18	Project Infrastructure	30
1.18.1	Site Access Road	30
1.18.2	Tailings Storage Facilities (TSF)	30
1.18.3	Camp Accommodation	30
1.18.4	Water Supply	31
1.18.5	Transmission Line	31
1.18.6	Airstrip	31
1.18.7	Buildings	31
1.19	Market Studies and Contracts	34
1.20	Environmental Studies, Permitting and Social or Community Impact	34
1.21	Capital and Operating Costs	34
1.22	Economic Analysis	34
1.23	Adjacent Properties	34
1.24	Other Relevant Data and Information	34
1.25	Interpretation and Conclusions	34

Pre-Feasibility Study

1.26	Recommendations	35
2	INTRODUCTION.....	37
2.1	Qualifications, Experience, and Independence.....	37
2.2	Effective Date	45
3	RELIANCE ON OTHER EXPERTS.....	46
4	PROPERTY DESCRIPTION AND LOCATION.....	47
4.1	Location.....	47
4.2	Mining Legislation, Administration and Rights	48
4.3	Mineral Concessions	48
4.4	Coordinate System.....	49
5	ACCESSIBILITY, CLIMATE, LOCAL RESOURCES, INFRASTRUCTURE, AND PHYSIOGRAPHY.....	50
5.1	Accessibility.....	50
5.2	Climate	50
5.3	Geomorphology.....	51
5.4	Local Resources and Infrastructure	51
6	HISTORY	54
6.1	History of Exploration	54
6.2	History of Mineral Tenure.....	54
6.3	Property Results – Previous Owners	56
6.4	History of Resource Estimation.....	56
6.4.1	2004 historical resource estimate (not compliant with NI 43-101).....	56
6.4.2	2014 historical resource estimate.....	57
6.4.3	2017 historical resource estimate.....	57
6.4.4	2018 historical resource estimate.....	57
6.4.5	2021 historical resource estimate.....	59
6.4.6	Summary of historical resource estimate	61
7	GEOLOGICAL SETTING AND MINERALIZATION	63
7.1	Regional Geology.....	63
7.2	Stratigraphy.....	64
7.3	Metamorphism and Structural Deformation	66
7.4	Hydrothermal Alteration.....	67
7.5	Mineralization	68
7.6	Mineralization Thicknesses and Orientation	69
7.6.1	Esperança South.....	69
7.6.2	Esperança Center	70

Pre-Feasibility Study

7.6.3	Esperança East.....	70
7.6.4	True Thickness.....	70
8	DEPOSIT TYPE	71
9	EXPLORATION	72
9.1	Exploration Program.....	72
9.1.1	Barrick (1995 to 1996).....	72
9.1.2	TriStar (2011 to Present).....	73
9.2	Geochemical Soil Sampling	73
9.3	Mapping.....	73
9.4	Geophysical Surveys.....	75
9.5	Petrophysical Downhole Surveying and Optical Televiewer (OTV).....	75
9.6	Multi-Element Chemistry	77
9.7	LIDAR Topography and Aerial Imagery	80
9.8	Density	81
10	DRILLING	82
10.1	Diamond Drilling	83
10.2	Reverse Circulation Drilling.....	83
10.1	Summary of Drilling	84
10.1	Sampling	84
10.1.1	RC Sampling.....	84
10.1.2	Core Sampling	85
10.1.3	Core Logging.....	85
10.1.4	Assay Accuracy and Reliability	85
10.2	Surveying	86
10.2.1	Collar Surveying.....	86
10.2.2	Downhole Surveying	86
10.3	Interpretation	87
10.3.1	Esperança South.....	87
10.3.2	Esperança Center	87
10.3.3	Esperança East.....	87
10.3.4	True Thickness.....	88
11	SAMPLE PREPARATION, ANALYSES, AND SECURITY	89
11.1	Bulk Density	89
11.2	Sample Custody Security.....	90
11.3	Laboratory Sample Preparation	91
11.3.1	Diamond Drillholes	91

Pre-Feasibility Study

11.3.2	Reverse Circulation Drillholes	92
11.3.3	Lab Preparation for Fire Assays	92
11.3.4	Lab Preparation for Leachwell Assays	92
11.4	Sample Analysis	93
11.4.1	Fire Assays	93
11.4.1	Leachwell Assays	93
11.5	Quality Assurance and Quality Control (QAQC)	93
11.5.1	Analysis of Standards	93
11.5.2	Prepared Reference Material (PRM)	93
11.5.3	Duplicate Analysis	94
11.5.4	Blanks Analysis	95
11.5.5	Metallic Screen Assays	95
11.5.6	Leachwell Assays	96
11.6	Adequacy of Procedures	97
12	DATA VERIFICATION	98
12.1	Verification of Drillhole Data	98
12.1.1	TriStar assay data	98
12.1.2	TriStar collar coordinates	98
12.1.3	Barrick assay data	99
12.1.4	Barrick collar coordinates	101
12.2	Verification of Topography Data	101
12.3	Adequacy of Data	102
12.4	Site Visit	102
13	MINERAL PROCESSING AND METALLURGICAL TESTING	103
13.1	Introduction	103
13.2	Previous Testwork by Others	104
13.3	Phase One Testwork	105
13.3.1	Sample Collection	105
13.3.2	Sample Preparation	105
13.3.3	Analysis and Assay	105
13.3.4	Bond Grinding and Abrasion Testing	106
13.3.5	Whole Ore Cyanidation	106
13.3.6	GRG Gravity Concentration	106
13.3.7	Bulk Gravity Concentration	106
13.3.8	Cyanidation of Gravity Concentration Products	106
13.3.9	Flotation	107
13.3.10	Cyanidation of Flotation Products	107

Pre-Feasibility Study

13.4	Phase Two Testwork, TriStar	107
13.5	Phase Three Testwork, TriStar	109
14	MINERAL RESOURCE	111
14.1	Database	112
14.1.1	Coordinate System	112
14.1.2	Drillhole database	112
14.1.3	Collars	113
14.1.4	Down-hole surveys	113
14.1.5	Assays	114
14.1.6	Topography	115
14.1.7	Density	117
14.2	Modelling of Local Bedding Orientation	117
14.3	Data Analysis and Interpretation	117
14.3.1	Erosional surfaces	117
14.3.2	Surface enrichment layer	121
14.3.3	Litho-geochemical units	123
14.3.4	Variograms	126
14.4	Domains for Resource Modelling	129
14.5	Estimation Method	130
14.5.1	Recoverable resources within large blocks	130
14.5.2	Estimation parameters	132
14.6	Classification	135
14.6.1	Conditional simulation	136
14.6.2	Procedure for quantifying uncertainty on in situ gold content in annual production increments	136
14.7	Reporting Pit Shell	139
14.8	Block Model Validation	139
14.8.1	Validation with independent block model	140
14.9	QP Opinion	141
14.10	Current Resource Estimate	154
14.10.1	Comparison to the previous estimate	155
15	MINERAL RESERVE ESTIMATES	156
16	MINING METHODS	157
16.1	Geotechnical Investigation	157
16.1.1	Field Visit	157
16.1.2	Rock Mass Classification	164
16.1.3	Kinematic and Stability Analysis – Pit 1	171

Pre-Feasibility Study

16.1.4	Kinematic and Stability Analysis – Pit 2	178
16.1.5	Kinematic and Stability Analysis – Pit 3	183
16.1.6	Stability Analysis – Pit 4	189
16.1.7	Waste Deposition Stability Analysis	191
16.1.8	Final Considerations Based on Slope Stability Analysis Results.....	195
16.2	Pit Optimization	196
16.3	Mining Dilution and Losses	200
16.3.1	Selective Mining Unit (SMU)	200
16.3.2	Dilution Estimate	201
16.3.3	Results	203
16.4	Pit Design	203
16.5	Mine Schedule.....	206
16.5.1	Mine Schedule Design	206
16.6	Waste Disposal	218
16.7	Production Plan	218
16.7.1	Mining Fleet.....	219
16.7.2	Access Routes	219
16.7.3	Drilling and Blasting	219
16.8	Mine Fleet Sizing.....	220
16.8.1	Ore and Waste Rock Excavation and Load.....	222
16.8.2	Wheel Loader for reclaiming Ore from ROM Stockyard.....	223
16.8.3	Transport.....	224
16.8.4	Truck Fleet.....	224
16.8.5	Mine Support Services	226
16.9	Hydrology	227
17	RECOVERY METHODS.....	228
17.1	Process Flowsheet and Basic Project Criteria	228
17.1.1	Primary Crusher	230
17.1.2	Primary Stockpile	231
17.1.3	Grinding	231
17.1.4	Leach/CIL.....	231
17.1.5	Tailings Wash Thickener.....	232
17.1.6	Acid Washing and Carbon Regeneration	233
17.1.7	Carbon Regeneration and Gold Smelting	234
17.2	Processing Plant Operations.....	235
17.3	Reagents and Consumables Facility.....	236
17.4	Freshwater Catchment and Distribution System.....	239

Pre-Feasibility Study

17.5	Ancillary Facilities	239
17.6	Power Distribution	240
17.6.1	Preliminary Conceptual Plant Layout	240
18	PROJECT INFRASTRUCTURE	242
18.1	Explosive Magazine	242
18.2	Waste Dump.....	242
18.3	Tailings Facilities	244
18.4	Camp Accommodation	245
18.5	Site Infrastructure	246
18.5.1	Mine dewatering and conveyance.....	246
18.5.2	Potable Water	247
18.5.3	Water Supply.....	247
18.5.4	Sewage Treatment.....	248
18.5.5	Airstrip	248
18.5.6	Communication	248
18.6	Buildings.....	248
18.6.1	Administration Building.....	248
18.6.2	Maintenance Facility	248
18.6.3	Fuel and Lubricant Storage and Distribution	248
18.6.4	Air.....	249
18.6.5	Assay Laboratory	249
18.6.6	Security Building	249
18.6.7	Miscellaneous Buildings	249
18.7	Site Access.....	249
18.7.1	Site Access Road.....	249
18.7.2	Site Roads.....	249
18.8	Power Supply	249
18.8.1	Future Expansion	250
18.9	Project Layout	250
19	MARKET STUDY AND CONTRACTS	252
19.1	Market Study	252
19.2	Refining, Transportation, and Insurance	252
20	ENVIRONMENTAL STUDIES, PERMITTING AND SOCIAL OR COMMUNITY IMPACT	253
20.1	Overview of Regulatory Framework for Environmental Licensing	253
20.2	Environmental Permitting Activities 2020/2021.....	254
20.3	Key Socio-Environmental Considerations.....	256

Pre-Feasibility Study

20.4	Closure and Reclamation	257
21	CAPITAL AND OPERATING COSTS	258
21.1	Capital Costs	258
21.1.1	Basis of Estimate	258
21.1.2	Mining Costs	258
21.1.3	Tailings Facility.....	262
21.1.4	Processing Plant and Infrastructure	262
21.1.5	Capital Cost Summary	266
21.1.6	QP Opinion.....	267
21.2	Operating Costs	267
21.2.1	Summary of OPEX.....	267
21.2.2	Manpower	268
21.2.3	Mining	268
21.2.4	Processing	272
21.2.5	General and Administration.....	273
22	ECONOMICAL ANALYSIS	274
22.1	Taxes.....	274
22.1.1	List of relevant taxes	274
22.1.2	Tax regime	274
22.2	Fiscal Benefits at Federal Level	274
22.2.1	SUDAM – Income Tax Benefit (Government Grant)	274
22.2.2	Social Contribution	275
22.2.3	Refundable Tax.....	275
22.3	Royalties.....	275
22.3.1	Royalty payable to the Federal Government – CFEM.....	275
22.3.2	Private Royalties (NSR)	275
22.4	Depreciation	275
22.5	Sensitivity Analysis.....	279
23	ADJACENT PROPERTIES	281
24	OTHER RELEVANT DATA INFORMATION	282
25	INTERPRETATION AND CONCLUSIONS	283
26	RECOMMENDATIONS	284
27	REFERENCES.....	286

Pre-Feasibility Study

TABLE LIST

Table 1-1 Mineral Resource Estimate	28
Table 1-2 Mineral Reserves	29
Table 1-3 Mining schedule of CDS Project	30
Table 2-1 Qualified Persons	38
Table 6-1 Mineral resource estimate for the Castelo de Sonhos gold project (with an effective date of December 31, 2020) above a reporting cut-off of 0.3 g/t Au.....	59
Table 6-2 Historical Mineral Resources for the Castelo de Sonhos Gold Project	62
Table 8-1 Geological characteristics of Castelo de Sonhos and other modified paleo-placers.....	71
Table 9-1 Summary of exploration work completed on the Castelo de Sonhos property.....	72
Table 10-1 Summary of the drilling campaign completed in the Project.	84
Table 11-1 Commercial Analytical Laboratories utilized by TriStar	89
Table 11-2 External QAQC samples included at the site by TriStar in the sample stream	93
Table 14-1 Numbers and file names for erosional surfaces.....	118
Table 14-2 Parameters for median indicator variogram models.....	126
Table 14-3 Block model configuration in each sub-area.....	132
Table 14-4 – Variogram model parameters used for independent ordinary kriging block model.....	140
Table 14-5 - Kriging search neighborhood parameters for independent ordinary kriging model.....	141
Table 14-6 Mineral Resource Estimate for the Castelo de Sonhos gold project	154
Table 14-7 Comparison of current and previous resource estimates for the Castelo de Sonhos Project.....	155
Table 15-1 Mineral Reserves	156
Table 16-1 Uniaxial compressive test results (UCS).....	166
Table 16-2 Uniaxial compression test (UCS) purged.....	166
Table 16-3 Indirect tensile strength test.....	167
Table 16-4 Indirect tensile strength test.....	167
Table 16-5 Intact rock parameters	167
Table 16-6 Rock mass properties	168
Table 16-7 Waste Pile Geometric Parameters.....	191
Table 16-8 Rock Mass Parameters.....	193
Table 16-9 Results of safety factors.....	193
Table 16-10 Summary results for limit-equilibrium slope stability analysis.....	195
Table 16-11 Pit Optimization First Pass Parameters	197
Table 16-12 Nested pits results for Esperança South.....	198
Table 16-13 Nested pits results for Esperança Center	199
Table 16-14 Nested pits results for Esperança East.....	200
Table 16-15 Pit Optimization Results Summary.....	200
Table 16-16 Mining dilution block model properties	201
Table 16-17 Pit design parameters	203
Table 16-18 Pit Design Results.....	204
Table 16-19 Mining Schedule Production	206
Table 16-20 Waste dumps design parameters	218
Table 16-21 Waste dumps volume and areas.....	218
Table 16-22 Equipment Quantitative.....	221
Table 16-23 Equipment Specification	222
Table 16-24 Excavation and Load Equipment	223

Pre-Feasibility Study

Table 16-25 Wheel Loader	224
Table 16-26 Truck Productivity	225
Table 16-27 Year-by-year summary of usage of 42t trucks	225
Table 16-28 Fleet worked hours per year per Equipment	226
Table 16-29 Complete List of Equipment.....	227
Table 17-1 Reagents and Consumables Consumption.....	237
Table 21-1 Fleet Acquisitions by Year	259
Table 21-2 Initial Mine Fleet and Sustaining CAPEX.....	261
Table 21-3: Summary of tailings dam costs	262
Table 21-4: Process and Infrastructure Initial Capital Cost Summary.....	266
Table 21-5: Initial Capital Cost Summary.....	267
Table 21-6: Sustaining Capital Cost Summary	267
Table 21-7: Life of Mine Operating Costs	268
Table 21-8 Project Direct Labor	268
Table 21-9 Hourly Costs for Mining Equipment.....	269
Table 21-10 Summary of Mining Operating Costs	271
Table 21-11: Process Plant Operating Cost.....	272
Table 21-12: Process Plant Reagents and Consumables Costs.....	273
Table 21-13: General and Administration	273
Table 22-1 Selling Prices and Taxes	276
Table 22-2 Operating income statement.....	277
Table 22-3 Project cash flow.....	278
Table 22-4 Economical Analysis Summary.....	279

Pre-Feasibility Study

FIGURE LIST

Figure 1-1: Project Layout.....	33
Figure 4-1 The location of the Project in Brazil	47
Figure 4-2 Mineral concessions for the Project area are shown by yellow outline.	49
Figure 5-1 Image taken from a drone showing the airstrip located in Esperança Center, with camp buildings in the background.	50
Figure 5-2 Variations in average daily temperature highs and lows (orange graph in degrees Celsius) and total monthly rainfall (teal graph in millimeters), from 1985 to 2015 for southern Pará State.....	51
Figure 5-3 Panoramic view of the village of Castelo de Sonhos, looking north along highway BR-163.....	52
Figure 6-1 Artisanal miners or garimpeiros (left) and abandoned excavations or garimpos (right) at Castelo de Sonhos Gold Project.	54
Figure 6-2 Plan map showing the continuity of the hand-dug garimpos (in blue) mirroring the mineralized conglomerate band outcrop (in green).	55
Figure 6-3, Model of litho-geochemical units on cross-section B-B' on the southwest arm of Esperança South, where the mafic dykes cross.....	60
Figure 6-4 Median indicator variography for the ferrous sediments, with the red line showing the omnidirectional variogram in the bedding plane and the dotted dark red line showing the variogram perpendicular to bedding. ...	61
Figure 7-1 Map of the Nuna Super-Continent, with location, at the time, of 10 gold deposits that are at least 2.0 billion years old. The "S" marks the location of the South Pole when Nuna formed; (right) The modern positions of the continental crust that comprised Nuna. (Source: Eglington, 2015).	63
Figure 7-2 Amazonian Craton and its major geochronological domains (Source: Klein et al., 2017).....	64
Figure 7-3 Schematic stratigraphy of the Castelo dos Sonhos Formation.	65
Figure 7-4 Schematic stratigraphy of the main units within the central conglomeratic band of Castelo dos Sonhos Formation, and conceptual model of the depositional environment. (Source: Modified by Karpeta, 2016, after McGowan and Groat, 1971).....	66
Figure 7-5 Map and schematic cross-section of the bedrock geology of the Castelo de Sonhos plateau.....	67
Figure 9-1 Soil sample anomalies (isolines) and mapped metaconglomerate bands (green hatch) at Castelo de Sonhos.....	74
Figure 9-2 OTV image of a diamond hole compared with actual core from the same interval.	76
Figure 9-3 Example of OTV image in an RC drillhole section.	76
Figure 9-4 Example of clusters developed by machine learning from 4A-ICP multi-element chemistry, and correlatable from hole to hole, with the interpretation of marker horizons.....	77
Figure 9-5 Preliminary interpretation of surficial geology using multielement geochemical clusters and information from 2D surface data sets such as airborne geophysics.....	78
Figure 9-6 Model of litho-geochemical units on cross-section A-A' on the north arm of Esperança South.	79
Figure 9-7 Model of litho-geochemical units on cross-section B-B' on the southwest arm of Esperança South, where the mafic dykes cross.....	80
Figure 9-8 Areal extent of LIDAR and orthophoto provided by Geosolid. Red outline shows current concession boundaries.	81
Figure 10-1 Diamond (blue) and RC (red) drillholes.	82
Figure 11-1 Density determination for sample 141/014	90
Figure 11-2 Drillhole samples collected and bagged in the core storage area at the site	91
Figure 11-3 Control chart for PRM prepared with ITAK-536 for 2020	94
Figure 11-4 Comparison of gold assays from field duplicates; samples analyzed by fire assay are shown in blue, those analyzed by the Leachwell method are shown in green.....	95

Pre-Feasibility Study

Figure 11-5 Comparison between results of conventional Fire Assays and Metallic Screen Assays. Green squares show samples for which Acme did both assays; blue triangles show samples for which SGS did the Fire Assay and Acme did the Metallic Screen Assay	96
Figure 12-1 Comparison of Barrick ½-core assays to TriStar ¼-core assays, with Barrick assays having been composited to the 2m intervals sampled by TriStar.	100
Figure 13-1 “Whole Ore” Cyanidation at Various Grind Size and Cyanide Strength	103
Figure 13-2 “Whole Ore” Cyanidation at P80 105 microns and 1.0 g/l Cyanide.....	104
Figure 14-1 The deposit sub-areas (in blue) covered by the current resource estimate.	112
Figure 14-2 Assay selection hierarchy criteria at Castelo de Sonhos.	114
Figure 14-3 An example of the LIDAR topography’s ability to identify surface depressions of garimpos.	116
Figure 14-4 Local bedding orientations modelled from bases and non-erosional tops of litho-geochemical units on the A-A’ cross-section shown in Figure 9-6.....	117
Figure 14-5 Boxplots of gold assays in Esperança South for the three erosional packages separated by the unconformities.....	119
Figure 14-6 Boxplots of gold assays that lie between the fourth and fifth erosional surfaces, in Esperança Center and Esperança South.	120
Figure 14-7 Map view of the areal extent of the thin surface enrichment layer in Esperança South.	121
Figure 14-8 Map view of the areal extent of the thin surface enrichment layer in Esperança Center.....	122
Figure 14-9 Map view of the areal extent of the thin surface enrichment layer in Esperança East.	123
Figure 14-10 Boxplots of gold assay grade distributions in four domains in Esperança South	125
Figure 14-11 Median indicator variography for ferrous sediments, with the solid red line showing the omnidirectional variogram in the bedding plane and the dotted dark red line showing the variogram perpendicular to bedding.	127
Figure 14-12 Median indicator variography for non-ferrous sediments, with the solid green line showing the omnidirectional variogram in the bedding plane and the dotted dark green line showing the variogram perpendicular to bedding.	127
Figure 14-13 Median indicator variography for the mafic dykes, with the solid blue line showing the omnidirectional variogram in the average dip plane of the dykes and the dotted darker blue line showing the variogram perpendicular to the dykes.	128
Figure 14-14 Median indicator variography for the surface enrichment layer, with the solid light purple line showing the omnidirectional variogram in the horizontal direction and the dotted darker purple line showing the variogram in the vertical direction.	128
Figure 14-15 Schematic showing the difference between a conventional single-estimate block model and a recoverable-resources block model that provides an estimate of the SMU grade distributions within large blocks.	131
Figure 14-16 Two examples of the local uncertainty in annual gold content, as calculated using conditional simulation. The probability distribution shown in a) is for the block annotated as A on the following figure; the probability distribution shown in b) is for the block annotated as B on the following figure.	137
Figure 14-17 Detail of the final classification codes on the 572 – 576 m bench of Esperança South. The green A and B labels mark the locations of the two blocks whose conditional simulation results are shown in the previous figure.....	138
Figure 14-18 Comparison of MIK estimate of block average grade to the average of assays that fall within 20x20x4m blocks in Esperança South, with data colour-coded according to the number of assays in the block.	140
Figure 14-19 Resource validation - Esperança South region of Castelo de Sonhos - Histogram (MIK – TriStar in red, OK GE21 in blue, NN in yellow, data in green).....	142
Figure 14-20 Resource validation - Esperança South region of Castelo de Sonhos - Histogram (MIK – TriStar in red, OK GE21 in blue, NN in yellow, data in green).....	143
Figure 14-21 Resource validation - Esperança South region of Castelo de Sonhos - Histogram (MIK – TriStar in red, OK GE21 in blue, NN in yellow, data in green).....	144

Pre-Feasibility Study

Figure 14-22 Resource validation - Esperança South region of Castelo de Sonhos - Histogram (MIK – TriStar in red, OK GE21 in blue, NN in yellow, data in green)	145
Figure 14-23 Resource validation - Esperança Center region of Castelo de Sonhos	146
Figure 14-24 Resource validation - Esperança Center region of Castelo de Sonhos	147
Figure 14-25 Resource validation - Esperança Center region of Castelo de Sonhos	148
Figure 14-26 Resource validation - Esperança Center region of Castelo de Sonhos	149
Figure 14-27 Resource validation – Esperança East region of Castelo de Sonhos. Histogram (MIK – TriStar in red, OK GE21 in blue, NN in yellow, data in green)	150
Figure 14-28 Resource validation – Esperança East region of Castelo de Sonhos - Swath Plot in the east-west direction (MIK – TriStar in red, OK GE21 in blue, NN in yellow, data in green)	151
Figure 14-29 Resource validation – Esperança East region of Castelo de Sonhos - Swath Plot in the north-south direction (MIK – TriStar in red, OK GE21 in blue, NN in yellow, data in green)	152
Figure 14-30 Resource validation – Esperança East region of Castelo de Sonhos - Swath Plot in the vertical direction (MIK – TriStar in red, OK GE21 in blue, NN in yellow, data in green)	153
Figure 16-1 Outcrop in the border of garimpo area in the Esperança South area	158
Figure 16-2 Outcrop and water table in the border of garimpo area in the Esperança South area	159
Figure 16-3 Outcrop of conglomerates showing no fracture system in a local scale.....	160
Figure 16-4 Drillcore boxes in the shallow saprolitic zone with two fracturing families.....	161
Figure 16-5 Drillcore box in transition from saprolitic to fresh-rock zone with local friable intercepts (shallow than 43m depth).....	162
Figure 16-6 Drillcore box in fresh rock zone showing conglomerate intercept.....	163
Figure 16-7 Drillcore boxes showing fresh rock zone with one fracturing family with high RQD values and high fracturing spacing.....	164
Figure 16-8 Stereogram from OTV surveyed structures showing two main structures, 24/286 and 17/035.	165
Figure 16-9 Results obtained with RocData.....	168
Figure 16-10 Castelo de Sonhos Project open pits.....	170
Figure 16-11 Pit 1 sectors.....	171
Figure 16-12 Kinematic analysis for the slope T1 showing 10% of probability for planar rupture	172
Figure 16-13 Kinematic analysis for the slope T1 showing 4% of probability for toppling rupture.....	172
Figure 16-14 Kinematic analysis for the slope T1 showing 12% of probability for wedge rupture.....	173
Figure 16-15 Kinematic analysis for the slope T2 showing 10% of probability for planar rupture	173
Figure 16-16 Kinematic analysis for the slope T2 showing 3% of probability for toppling rupture.....	174
Figure 16-17 Kinematic analysis for the slope T2 showing 16% of probability for wedge rupture.....	174
Figure 16-18 Kinematic analysis for the slope T3 showing 9% of probability for planar rupture	175
Figure 16-19 Kinematic analysis for the slope T3 showing 8% of probability for toppling rupture.....	175
Figure 16-20 Kinematic analysis for the slope T3 showing 12% of probability for wedge rupture.....	176
Figure 16-21 Limit-equilibrium analysis results for Section 01 with FS (security factor) = 1.62.....	176
Figure 16-22 Limit-equilibrium analysis results for Section 02 with FS (security factor) = 1.68.....	177
Figure 16-23 Pit 2 sectors.....	178
Figure 16-24 Kinematic analysis for the slope T4 showing 6% of probability for planar rupture	179
Figure 16-25 Kinematic analysis for the slope T4 showing 9% of probability for toppling rupture.....	179
Figure 16-26 Kinematic analysis for the slope T4 showing 9% of probability for wedge rupture.....	180
Figure 16-27 Kinematic analysis for the slope T5 showing 9% of probability for planar rupture	180
Figure 16-28 Kinematic analysis for the slope T5 showing 5% of probability for toppling rupture.....	181
Figure 16-29 Kinematic analysis for the slope T5 showing 5% of probability for wedge rupture.....	181
Figure 16-30 Limit-equilibrium analysis results for Section 03 with FS (security factor) = 1.58.....	182

Pre-Feasibility Study

Figure 16-31 Limit-equilibrium analysis results for Section 04 with FS (security factor) = 1.62.....	182
Figure 16-32 Pit 3 sectors.....	183
Figure 16-33 Kinematic analysis for the slope T6 showing 11% of probability for planar rupture	184
Figure 16-34 Kinematic analysis for the slope T6 showing 5% of probability for toppling rupture.....	184
Figure 16-35 Kinematic analysis for the slope T6 showing 15% of probability for wedge rupture.....	185
Figure 16-36 Kinematic analysis for the slope T7 showing 12% of probability for planar rupture	185
Figure 16-37 Kinematic analysis for the slope T7 showing 4% of probability for toppling rupture.....	186
Figure 16-38 Kinematic analysis for the slope T7 showing 15% of probability for wedge rupture.....	186
Figure 16-39 Limit-equilibrium analysis results for Section 05 with FS (safety factor) = 1.73	187
Figure 16-40 Limit-equilibrium analysis results for Section 06 with FS (safety factor) = 1.53	188
Figure 16-41 Limit-equilibrium analysis results for Section 07 with FS (safety factor) = 1.53	188
Figure 16-42 Limit-equilibrium analysis results for Section 08 with FS (safety factor) = 1.48	189
Figure 16-43 Pit 4 sectors.....	189
Figure 16-44 Limit-equilibrium analysis results for Section 09 with FS (safety factor) = 1.54	190
Figure 16-45 Limit-equilibrium analysis results for Section 10 with FS (safety factor) = 1.40	190
Figure 16-46 Limit-equilibrium analysis results for Section 11 with FS (safety factor) = 1.48	191
Figure 16-47 Stability analysis - Section BB / PDE EC	193
Figure 16-48 Stability analysis - Section AA / PDE EE	194
Figure 16-49 Stability analysis - Section AA / PDE NORTH	194
Figure 16-50 Stability analysis - Section BB.....	195
Figure 16-51 Pit by Pit Graph for Esperança South	197
Figure 16-52 Pit by Pit Graph for Esperança Center.....	198
Figure 16-53 Pit by Pit Graph for Esperança East	199
Figure 16-54 Contact between blocks for dilution estimate.....	202
Figure 16-55 Final Pit – CDS Project.....	205
Figure 16-56 Year 01.....	207
Figure 16-57 Year 02.....	208
Figure 16-58 Year 03.....	209
Figure 16-59 Year 04	210
Figure 16-60 Year 05.....	211
Figure 16-61 Year 06.....	212
Figure 16-62 Year 07	213
Figure 16-63 Year 08.....	214
Figure 16-64 Year 09.....	215
Figure 16-65 Year 10.....	216
Figure 16-66 Final pit.....	217
Figure 17-1 Simplified Block Diagram Proposed Flowsheet	229
Figure 17-2 Simplified Conceptual Flowsheet - Primary Crushing and Coarse Ore Stockpile	230
Figure 17-3 Simplified Conceptual Flowsheet – Grinding and Classification	231
Figure 17-4 Simplified Conceptual Flowsheet – Leaching and CIL.....	232
Figure 17-5 Simplified Conceptual Flowsheet – Cyanide Destruction and Tailing Treatment.....	233
Figure 17-6 Simplified Conceptual Flowsheet – Acid Washing of Carbon and Electrowinning	234
Figure 17-7 Simplified Conceptual Flowsheet – Carbon Regeneration and Smelting.....	235
Figure 17-8 Preliminary Conceptual Plant Layout.....	241
Figure 18-1 Waste Piles Layout for Castelo de Sonhos Project	243

Pre-Feasibility Study

Figure 18-2: Tailing Storage Facility Design 244
Figure 18-3 Project Layout..... 251
Figure 22-1 Sensitivity analysis..... 280

Pre-Feasibility Study

UNITS, SYMBOLS AND ABBREVIATIONS

°F	Fahrenheit
µm	Micron
4A - ICP	Four Acid Inductively coupled plasma
AACE	American Association of Cost Engineers
AARL	Anglo American Research Laboratories (carbon stripping method)
ABNT	Brazilian National Standard Organization
ADA	Directed Affected Area
Ai	Abrasion Index
ANM	Agência Nacional de Mineração
ASV	Vegetation Suppression Authorization
CAPEX	Capital Expenditure
CCD	Counter Current Decantation
CDF	Cumulative Distribution Functions
CDS	Castelo de Sonhos Gold Project
CFEM	Financial Compensation for the Exploration of Mineral Resources
CGL	Conglomeratic
CIL	Carbon in Leach
CIM	Canadian Institute of Mining Metallurgy and Petroleum
CIP	Carbon in Pulp
COFINS	Contribution for Social Security Financing
CONAMA	Concelho Nacional do Meio Ambiente
CRM	Certified Reference Material
CSA	CSA Global
CSLL	Social Contribution on Net Income
DCF	Discounted Cash Flow
DDH	Diamond drillhole
DGI	DGI Geoscience
DNPM	Departamento Nacional de Produção Mineral
DXF	Drawing Interchange Format
EC	Esperança Center
EE	Esperança East
EGL	Effective Grinding Length
EIA	Environmental Impact Assessment
ES	Esperança South
FOS	Safety Factor
ft	Feet
FUNAI	National Indian Foundation
FW	Footwall
g/l	grams per liter
g/t	Grams per tonne
Ga	Billion years
GE21	GE21 Consultoria Mineral
GFT	Gravity Face Tool
GIS	Geographic Information System
GPa	Giga Pascal
GPS	Global Positioning System
GRG	Gravity Recoverable Gold
HCE	Hydrologic Engineering Center
HMS	Hydrologic Modeling System
HW	Hangingwall
ICMBIO	Chico Mendes Institute for Biodiversity Conservation
ICMS	Tax on Circulation of Goods and Services for Interstate and Intercity Transportation and Communication
ICP	Inductively coupled plasma mass spectrometry
II	Import Tax
IK	Indicator Kriging
INCRA	National Land Reform Agency
IPI	Tax on Manufactured Products

Pre-Feasibility Study

IRPJ	Income tax
IRR	Internal rate of return
ISO	International Organization for Standardization
ISSQN	Tax upon services of any kind
Kg or kg	Kilogram
kV	Kilovolt
kW	Kilowatt
l	Liter
l/s	Liter per second
LI	Licença de Instalação
LIDAR	Light Detection and Ranging
LO	Licença de Operação
LOM	Life of Mine
LP	Licença Prévia
m³/h	Cubic meter per hour
Ma	Million Years
mA	Metamorphosed Sandstone
mAC	Metamorphosed Conglomeratic Arenites
MAIG	Member of the Australian Institute of Geoscientists
mC	Metamorphosed Conglomerates
mC1	Metamorphosed Clast-supported Conglomerate
mC2	Metamorphosed Matrix-supported Conglomerate
mC3	Metamorphosed Micro-conglomerate
MCDS	Mineração Castelo dos Sonhos Ltda.
MIK	Multiple Indicator Kriging
MLI	McClelland Laboratories
mm	Millimeter
MMA	Ministry of Environment
Moz	Million Troy Ounces
MP	Provisional Measures
MPa	Mega Pascal
Mtpa	Millions of tonnes per year
NI 43-101	National Instrument 43-101 – Standard of Disclosure for Mineral Projects
NPV	Net Present Value
NSR	Net Smelter Return
OPEX	Operational Expenditure
OTV	Optical Televiewer
oz	Troy Ounces
PAE	Plano de Aproveitamento Econômico
PCA	Plano de Controle Ambiental
PDE	Waste Dump
PEA	Preliminary Economic Assessment
PFS	Pre-Feasibility Study
PIS	Contribution to the Social Integration Plan
PMF	Probable Maximum Flood
ppb	Parts per Billion
ppm	Parts per Million
PRAD	Plan for the Recovery of Degraded Areas
PRM	Prepared Reference Material
pXRF	Portable X-Ray Fluorescence
QA/QC	Quality Assurance and Quality Control
QP	Qualified Person
RC	Reverse Circulation
RCA	Environment Control Report
RIMA	Relatório de Impacto Ambiental
RMB	RMB Consultoria Mineral
ROM	Run of Mine
RQD	Rock Quality Designation
SAD	South American Datum
SAG	Semi-Autogenous Grinding

Pre-Feasibility Study

SEM	Scanning Electron Microscope
SEMAS	Secretaria de Estado de Meio Ambiente e Sustentabilidade
SFB	Brazilian Forest Service
SI	International System of Units
SIRGAS	Sistema de Referencia Geocéntrico para Las Américas
SMBS	Sodium Metabisulfite
SMU	Selective Mining Unit
SUDAM	Superintendência do Desenvolvimento da Amazônia
t	Tonne
TDH	Total Dynamic Head
TDS	Total Dissolved Solids
TSF	Tailing Storage Facility
TSX	Toronto Stock Exchange
UC	Uniform Conditioning
US	United States
UTM	Universal Transverse Mercator
VoIP	Voice over Internet Protocol
WACC	Weighted Average Cost of Capital
WRD	Waste rock dump
WST	Water Service and Technologies
XRF	X-Ray Fluorescence

Pre-Feasibility Study**1 EXECUTIVE SUMMARY****1.1 Qualified Persons, Experience, and Independence**

The independent QP responsible for this report's content on issues related to mining, processing, and economic analysis is Porfírio Cabaleiro Rodriguez (FAIG, B.Sc.), a Principal Mining Engineer and Managing Director of GE21 Consultoria Mineral, who has at least 42 years of experience in all aspects of assessment of mining projects, from early exploration through to bankable feasibility studies.

The independent Qualified Person (QP) responsible for this report's content on issues related to Geology, Geotechnics and Mineral Resources is Leonardo M. Soares (MAIG, B.Sc.), a Master Geologist., who has 19 years of experience in Mineral Resource estimation for gold deposits.

The independent QP responsible for this report's content on issues related to Mineral Reserves estimation is Guilherme Gomides Ferreira (MAIG, B.Sc.), a Mining Engineer and Manager Engineer of GE21 Consultoria Mineral, who has at least 16 years of experience in mining projects.

The independent QP responsible for this report's content on issues related to Mine Fleet Dimensioning, Mine CAPEX and OPEX estimation is Ricardo Reis de Paula (MAIG, B.Sc.), a Mining Engineer and Master Engineer of GE21 Consultoria Mineral, who has at least 35 years of experience in mining projects.

The independent QP responsible for this report's content on issues related to Mine Dewatering and Water Supply is Dr. Martin Paul Boland (Chartered Professional and member of Geological Society of London), a PhD Geologist, from Piteau Associates, who has at least 30 years of experience in mining industry.

The independent QP responsible for this report's content on issues related to Tailing Storage Facility is Andries Jacobus Strauss (Professional Engineer and member of ECSA), a BSc Civil Engineer, from Knight Piesold Ltd., who has at least 20 years of experience in the industry.

1.2 Introduction

This Technical Report is a Pre-Feasibility Study of the Castelo de Sonhos Gold Project by updating the mineral resource estimates and performing, for the first time on this project, a reserve study.

1.3 Reliance on Other Experts

On issues related to ownership and mineral concession rights, the authors rely on legal opinions given to TriStar by its Brazilian lawyers. GE21's QP Guilherme Gomides Ferreira verified on ANM's online platform that status of each of the six Mineral Concessions is in accordance with the information in this Report.

On issues related to environmental permitting and studies, taxation and royalties, the authors rely on the information provided by TriStar.

Pre-Feasibility Study

1.4 Property Description and Location

The Castelo de Sonhos gold deposit lies on a plateau that rises 350 m above the cattle-grazing plains of southern Pará State in Brazil. The mineral concessions held by TriStar Gold's Brazilian subsidiary include four older concessions for which exploration reports have been submitted and that are now into the phase of permitting and environmental assessment, a fifth pending the approval of a partial exploration report and a sixth that was recently added and that is in its initial exploration phase.

1.5 Accessibility, Climate, Local Resources, Infrastructure, and Physiography

The project site is less than a one-hour drive from Castelo de Sonhos, a town on Brazilian Federal Highway 163, a major transportation corridor that connects the soy farms of Brazil's interior, about 1,000 km to the south, to ports on the Tapajós River. With airstrip on the plateau, the project can be reached directly by air; it is less than a one-hour flight from Alta Floresta, a city with commercial air service.

The sub-tropical climate poses no difficulties for mining operations, even during the rainy season. The project is connected to the national electrical grid via a spur that runs from the 138 kV line that runs along Highway 163, 15–20 km away.

The nearby town has banks, schools, a medical clinic, and a police station. As a major stop on Highway 163, Castelo de Sonhos has businesses that can repair and service heavy equipment. It is a source of both skilled and unskilled workers, as are other towns and cities to the north and south along the highway. Pará State, which is home to some of Brazil's biggest mining operations, has a long history of large mines; two of its federal universities have programs in the science and engineering, that support modern industrial mining.

1.6 History

The Castelo de Sonhos plateau was the site of a major gold rush several decades ago, as small-scale artisanal miners worked the creeks and streams that drain the plateau, extracting gold from the gravels. In 1995-1996, Barrick Gold drilled 23 holes on the plateau and identified the conglomerates that rim the plateau as the source of the alluvial gold. Artisanal miners then moved up onto the plateau and began digging huge trenches, following the dipping conglomerate band for many kilometers along strike, with their trenches extending down the dip of bedding until their inability to keep water out of the trenches caused almost all the miners to leave.

The project passed through the hands of Osisko before ending up with TriStar Gold in 2010. Since 2011, TriStar has been drilling and conducting field studies to advance the project toward its full feasibility study. Several resource estimates have been done, growing the in-situ gold contained in the project's resources from a few hundred thousand ounces in 2014.

1.7 Geological Setting and Mineralization

The Castelo de Sonhos Formation is a small remnant of sedimentary rock caught between continental plates that collided almost two billion years ago. Before the collisions that added crust to what is now the Amazonian plate, sediments ranging in size from sand to large boulders accumulated in an alluvial fan and marine delta near the shoreline of an ancient super-continent now referred to as "Nuna".

Pre-Feasibility Study

When the continental plates collided, a large granite intrusion formed below the sedimentary rocks, and dykes of molten material intruded into the sediments, metamorphosing them slightly. The sediments were folded into the bowl-shaped structure which eventually became a plateau because its silicified rocks were more resistant to weathering than the surrounding granites.

Most of the gold mineralization occurs in the conglomerate band, in the matrix between pebbles, and tends to be higher in a grade where large, abundant and well-rounded pebbles are evidence of fast-flowing water at the time of original deposition. Some of the gold has been remobilized, but only a short distance, by the hot fluids from the granites that post-date the original deposition of gold grains by 200 million years. Remobilized gold occurs along fractures and cracks in the metamorphosed conglomerates.

1.8 Deposit Types

Castelo de Sonhos is referred to as a “modified paleo-placer”. It is a “placer” because the free gold grains from higher elevations in the hinterland were transported downhill, toward the shore, and accumulated in the bottom gravels of rivers and creeks. It is “paleo” because it was formed two billion years ago, during the Paleoproterozoic Era (2,500 to 1,600 million years ago). It is “modified” because it has been slightly metamorphosed into hard and consolidated rock.

Other modified paleo-placers that now host operating mines include Tarkwa in Ghana and Jacobina in Brazil, both of which formed at the same time as Castelo de Sonhos, also along the coastline of Nuna. The vast Witwatersrand deposits are also paleo-placers, although these formed several hundred million years before the Nuna paleo-placers.

1.9 Exploration

The Barrick and TriStar exploration programs have consisted of sampling and analyses of soils, stream sediments, outcrops, trenches, and drillholes. They have also included airborne geophysical surveys, down-hole petrophysical logging, and imaging of the walls of drillholes using an optical televiewer. Along with surface reconnaissance and mapping, the field studies have confirmed the coincidence between gold mineralization and the conglomerate band.

In 2020, a high-precision survey of topography was conducted using LIDAR, along with the acquisition of high-resolution georeferenced aerial photographs of the entire plateau. Machine-learning has been used to identify in drillholes long intervals whose multi-element chemistry fingerprints are similar; these clusters have been correlated from hole to hole and developed into a 3D model of the litho-geochemistry and stratigraphy of the sub-surface.

1.10 Drilling

A combination of diamond drilling and reverse-circulation drilling has been used to test gold mineralization within the reach of open-pit mining methods, to a depth of approximately 150m. In places, holes have been drilled deeper. Recently, TriStar has begun testing potential targets that are more than 300m deep, in locations where granitic intrusions and dykes may have concentrated gold sufficiently to be amenable to underground mining methods.

Pre-Feasibility Study

By the end of May 2021, almost 611 holes had been drilled on the plateau, with a total length of more than 67,000m, almost all of it in the mineralized conglomerate band.

The drilling has established the broad geometry of the deposits, a bowl-shaped band of mineralized conglomerates many tens of square kilometers in its lateral extent. It has also confirmed the major structural offsets, two major faults that cause the mineralization in the Esperança East block of the deposit to be offset from the mineralization in the Esperança Center, and Esperança South blocks on either side.

Assays from the drilling campaigns have shown that most of the economically viable mineralization is in the 1–2 g/t range. Grades are occasionally above 10 g/t, usually in areas where gold has been remobilized.

1.11 Sample Preparation, Analyses, and Security

The Castelo de Sonhos project follows industry norms for sample preparation, with samples being crushed and then pulverized before a sub-sample is taken for chemical analysis. The assay database includes fire assays as well as assays done by the Leachwell method, an aggressive acid leaching method that analyzes a 1 kg sample that is much larger than the 50 g aliquot analyzed in a fire assay. Studies of the gold grain size distribution have established that the median grain size is approximately 100 microns. At this size, analysis of 1 kg of material provides data that are much more reliable for resource estimation purposes than analysis of only 50 g can provide. For this reason, Leachwell assays are preferred over fire assays for resource estimation. Fire assays are still used as the first assay for most drillholes because fire assays are less expensive than Leachwell assays and can provide a good first check for the higher-grade significant intervals that need a Leachwell assay.

In addition to the internal quality assurance and quality control (QA/QC) programs used by all the ISO-certified labs that have analyzed Castelo de Sonhos samples, TriStar also has an external QA/QC program that uses standards, blanks, and duplicates to monitor the reliability of the results reported by commercial laboratories. Recent improvements to TriStar's external QA/QC program include the use of "prepared reference materials" (PRMs) that provide more information on data quality than do the "certified reference materials" (CRMs) used previously. PRMs are blank RC chips spiked with carefully measured quantities of gold. Unlike CRMs, which are small packets of pulp powder that don't get crushed and pulverized, PRMs included in the sample stream look like regular RC samples and have to go through all the sample preparation steps before they can be analyzed.

Sample bags are sealed at the site, with the seals not being broken until the samples are in the custody of the laboratory.

1.12 Data Verification

TriStar maintains the drillhole data for the Castelo de Sonhos project in an MX Deposit database. Assay information in the digital database has been verified against original assay certificates each time that resources have been calculated, including this current resource estimate. No error in database compilation has been identified, and no inconsistency has been found in the way that multiple assays

Pre-Feasibility Study

are combined to give the grades used for resource estimation, which are Leachwell assays, if available, or fire assays otherwise.

Technical visit to project site was performed by the geologist Leonardo Soares and mining engineer Guilherme Gomides, between 26th and 27th of May 2021. During the technical visit the follow points were verified:

- Coreshed and drillhole intercepts with sampling registers.
- Geomechanical parameters related to the rock mass properties in the project as fracturing condition, orientation and spacing, weathering and strength of rock mass.
- Drillhole landmarks and topography registers.
- Outcrops along mineralization zones where garimpeiro pits were developed.
- Areas or waste pile installation.
- Drillhole logs at project office.

All the verifications results show that field conditions and checked information and registers are in accordance with assumptions and parameters of the Castelo de Sonhos Project for a pre-feasibility study level of confidence.

1.13 Mineral Processing and Metallurgical Testing

Metallurgical test work has confirmed that most of the gold occurs as free grains, with simple gravity methods of recovery achieving high recoveries, above 80% in lab-scale Knelson centrifuges and above 70% in bulk gravity concentration tests performed with the material ground to 75 microns. Abrasion and grinding tests of the Castelo de Sonhos quartzites show that they are abrasive and of medium hardness. Cyanidation tests show that high recoveries can be achieved with low reagent consumption, with or without pre-concentration by gravity methods.

Tests of a combination of gravity recovery and cyanidation on the material ground to 75 microns show that total metallurgical recoveries of 98% can be achieved with Castelo de Sonhos material in the 1–2 g/t range.

The testwork carried out with the samples indicates that the rock is amenable to all routes tested, with high recovery and low reagent consumption for any single process

1.14 Mineral Resource Estimates

In the current resource block model, the distribution of gold grades for volumes the size of truckloads has been estimated within 20x20x4m blocks using multiple indicator kriging (MIK). The grade interpolation makes use of the 3D model of litho-geochemical units, using its erosional surfaces as hard boundaries and its non-erosional surfaces as indications of bedding direction.

Resource classification involved two steps: 1) conditional simulation of gold grades so that the uncertainty on annual gold production could be evaluated; and, 2) development of an optimal pit shell to ensure that reported resources could be reached by an open pit operation using realistic assumptions

Pre-Feasibility Study

for technical and economic parameters. If the 90% confidence interval for the local distribution of gold metal content was less than $\pm 15\%$ of the mean, the block was classified as Indicated. Blocks where this degree of certainty could not be achieved were classified as Inferred; because of the search strategy used for grade estimation, blocks that do not have drillhole data within the range of the variogram were not classified and do not contribute to the resource estimate. No blocks were classified as Measured. Once the blocks had been classified using conditional simulation, a reporting pit shell was developed using Whittle. Blocks outside the reporting pit shell were removed from the classified resource inventory.

The classified resources for the Castelo de Sonhos project, reported within a pit shell, are summarized in Table 1-1 below.

Table 1-1 Mineral Resource Estimate

Classification	Tonnage (Mt)	Grade (g/t Au)	Metal Content (Moz Au)
Indicated	53.1	1.03	1.76
Inferred	26.0	0.88	0.74

*Effective date of October 4th, 2021, above a reporting cut-off of 0.26 g/t Au. The Qualified Person is Geol. Leonardo de Moraes Soares.

Notes:

1. *The reporting cut-off corresponds to the marginal cut-off grade for an open pit with processing + G&A cost of \$US 12/t, metallurgical recovery of 98% and a gold price of \$US 1,550/oz. To meet the requirement of “reasonable prospect for eventual economic extraction” the mineral resources must also fall within a bounding pit shell with 55° walls.*
2. *These are mineral resources and not reserves and as such do not have demonstrated economic viability.*
3. *The metal content estimates reflect gold in situ, and do not include factors such as external dilution, mining losses and process recovery losses.*
4. *TriStar is not aware of any environmental, permitting, legal, title, taxation, socio-economic, marketing, or political factors that might materially affect these mineral resource estimates.*

1.15 Mineral Reserve Estimates

Effective date for Mineral Reserves on the Castelo de Sonhos Project is October 4th, 2021. The ultimate pit and mine plan were guided by the Whittle optimization work completed by GE21. The mine plan developed in this report is based on Indicated Resources only as delineated in Section 14. Reserves are reported using a sales price of \$1,550/oz of gold. The Mineral Reserves Summary is presented on Table 1-2.

Pre-Feasibility Study

Table 1-2 Mineral Reserves

Area	Reserves Classification	Tonnage (Mt)	Au (g/t)	Ounces contained (Moz)
Esperança South	Probable	24.2	1.28	0.99
Esperança East	Probable	3.1	0.82	0.08
Esperança Center	Probable	11.4	0.78	0.29
Total	Probable	38.7	1.09	1.36

1. The Mineral Reserve estimate for the CDS deposit was reported using the 2014 CIM Definition Standards
2. Mineral Reserves were estimated using the Geovia Whittle 4.3 software and following the economic parameters:
 - a. Sale price gold metal = US\$1,550.00.
 - b. Mining costs: US\$2.17/t ore and waste mined.
 - c. Processing costs: US\$ 9.99/t milled.
 - d. Metallurgical recovery 98%
 - e. G&A: US\$13.6/oz.
3. Mineral Reserves are the economic portion of the Indicated Mineral Resources.
4. Mass dilution 3.9%, Grade dilution 4.5%, Ore loss 0%.
5. Final slope angle: 55° based on Geotechnical Document presented in Section 16.
6. The Qualified Person for the estimate is Guilherme Gomides Ferreira, BSc. (MEng), MAIG, an employee of GE21.

1.16 Mining Methods

Mining will be based on conventional open pit methods (drill-blast-load-haul), which are suited to the Project location, orebody, and local site conditions.

The mine planning model adopted was considered as a “diluted” model, adding approximately 3.9% mass dilution and 4.5% grade dilution to the source model.

GE21 also developed by geotechnical consultant, the definition of a single slope angle of 55° interramp for the final pit as used at mine design.

Open pit operations are anticipated to run for 11 years including Phase 1 (Esperança South) for the first 6 years of operation, and Phase 2 (Esperança East and Esperança Center) for years 7 through 11. The anticipated production rate is 3.6Mt of ore per year with a life-of-mine strip ratio of 9:1.

Owner-operated mining and fleet maintenance operations are planned for 365 days/year, with 3 8-hour shifts planned per day with 4 operating teams. Initially, mining will be undertaken using 4.5m³ bucket hydraulic excavators and 42t payload haul trucks, with blasting of ore and waste.

Table 1-3 below presents the production schedule for the CDS Project.

Pre-Feasibility Study

Table 1-3 Mining schedule of CDS Project

Mine Design Scheduling Mass diluted by 3.9%, Grade diluted by 4.5%							
Year	Target	ROM (Mt)	Waste (Mt)	Total Mov.	Au (g/t)	Ounces mined (koz)	Strip Ratio
1	ES	3.41	39.23	42.64	1.42	155.4	11.5
2	ES	3.60	42.46	46.06	1.30	150.4	11.8
3	ES	3.67	43.28	46.94	1.27	150.0	11.8
4	ES	3.29	44.64	47.93	1.43	151.7	13.6
5	ES	3.62	44.45	48.07	1.29	150.3	12.3
6	ES	3.65	28.92	32.56	1.16	135.6	7.9
7	ES & EE	3.55	22.26	25.81	1.02	116.0	6.3
8	EE & EC	3.65	19.78	23.43	0.69	81.1	5.4
9	EC	3.45	21.84	25.29	0.79	87.7	6.3
10	EC	3.63	21.93	25.56	0.83	97.1	6.1
11	EC	3.21	18.61	21.83	0.82	84.5	5.8
Total	-	38.72	347.40	386.12	1.09	1 359.7	9.0

1.17 Recovery Methods

The CDS processing plant will be fed with 3.65 Mt of ROM/year with a gold production of 146 koz/year in Phase 1 (Years 1 through 6) and 91 koz/year in Phase 2 (Years 7 through 11) after a 98% metallurgical recovery with a whole ore agitation leaching processing route.

1.18 Project Infrastructure

The infrastructure requirements for the Project are summarized in the following sections below.

1.18.1 Site Access Road

Castelo de Sonhos Village is located approximately 20 km from the Castelo de Sonhos Project. The main access site road will require an upgrade of 2 km from an existing road and a construction of 15.6 km extension road, 8 m width connecting the existing road to the process facility.

1.18.2 Tailings Storage Facilities (TSF)

The Tailing Storage Facilities (TSF) will ultimately occupy an area of 367 ha and accommodate 39 Mt of tailings at an in-situ density of 1.55t/m³

1.18.3 Camp Accommodation

There is an existing camp at the project that supports approximately forty people. The facilities at site include laundry, dorms, kitchen, warehouse, exploration office and generator house. The camp is connected to grid power, with a generator available to cover for any power outages.

During construction period the camp can be expanded to receive owner's teams that will be onsite. Contractors will supply their own accommodation facilities.

Pre-Feasibility Study**1.18.4 Water Supply**

Potable water will come from the wells drilled to support the plant. Water potability will be checked through water sample collection and analysis in capable laboratories.

A site-wide probabilistic water balance model has been constructed for Castelo de Sonhos using the industry-standard software GoldSim. Results of model simulations confirm that the water balance will be net-positive. A source of fresh-water supply for the process and/or for ancillary uses (fire, dust suppression, potable supply etc.) must nonetheless be established for contingency, or for those uses requiring a strictly prescribed chemical quality.

The process and tailings storage facility (TSF) water balance has been simulated for the projected LOM mill feed rate of 4 Mtpa and a discharged tailings slurry of 50% solids by mass. The total process plant water requirement will be around 463 m³/h on this basis. At mine start-up a raw water supply to cover all demand minus a small volume of water held as ore moisture will be required. This demand will rapidly diminish (within a few months) as the TSF supernatant pond becomes established.

1.18.5 Transmission Line

The project's electricity will come from a new 27 km transmission line that will connect to the 138kV substation in the village of Castelo de Sonhos.

1.18.6 Airstrip

There are currently two airstrips at site, one is 550 m in length by 30 m wide, and the other is 500 m in length by 20 m wide. The airstrips are suitable for helicopter landing as well as a single engine airplane (6 seaters).

1.18.7 Buildings**Administration**

The administration building will be of a single-storey cinder block construction and will contain general areas for engineering, geology, administration personnel, offices for the general manager, mine manager, plant manager, administration staff, chief engineer, chief geologist, EH&S and medical care room.

Maintenance Facility

This building will be placed near by the plant facility and will include four truck repair bays of approximately 36m X 12m x 12m eave height, warehouse 36m x10m x 7.5 m eave height, maintenance shop 27m x 10m x 7.5 m eave height, steel frame, non-insulated.

Assay Laboratory

A fully equipped assay laboratory will be located at the plant site. The laboratory will deliver daily analysis of mining and process samples.

Security Building

Pre-Feasibility Study

A single-storey prefabricated building will serve as a high-security facility. Doré produced by the project will be transported by helicopter from a heliport located close to this high-security facility.

Figure 1-1 presents the Conceptual Master Plan for the Castelo de Sonhos Project.

Pre-Feasibility Study

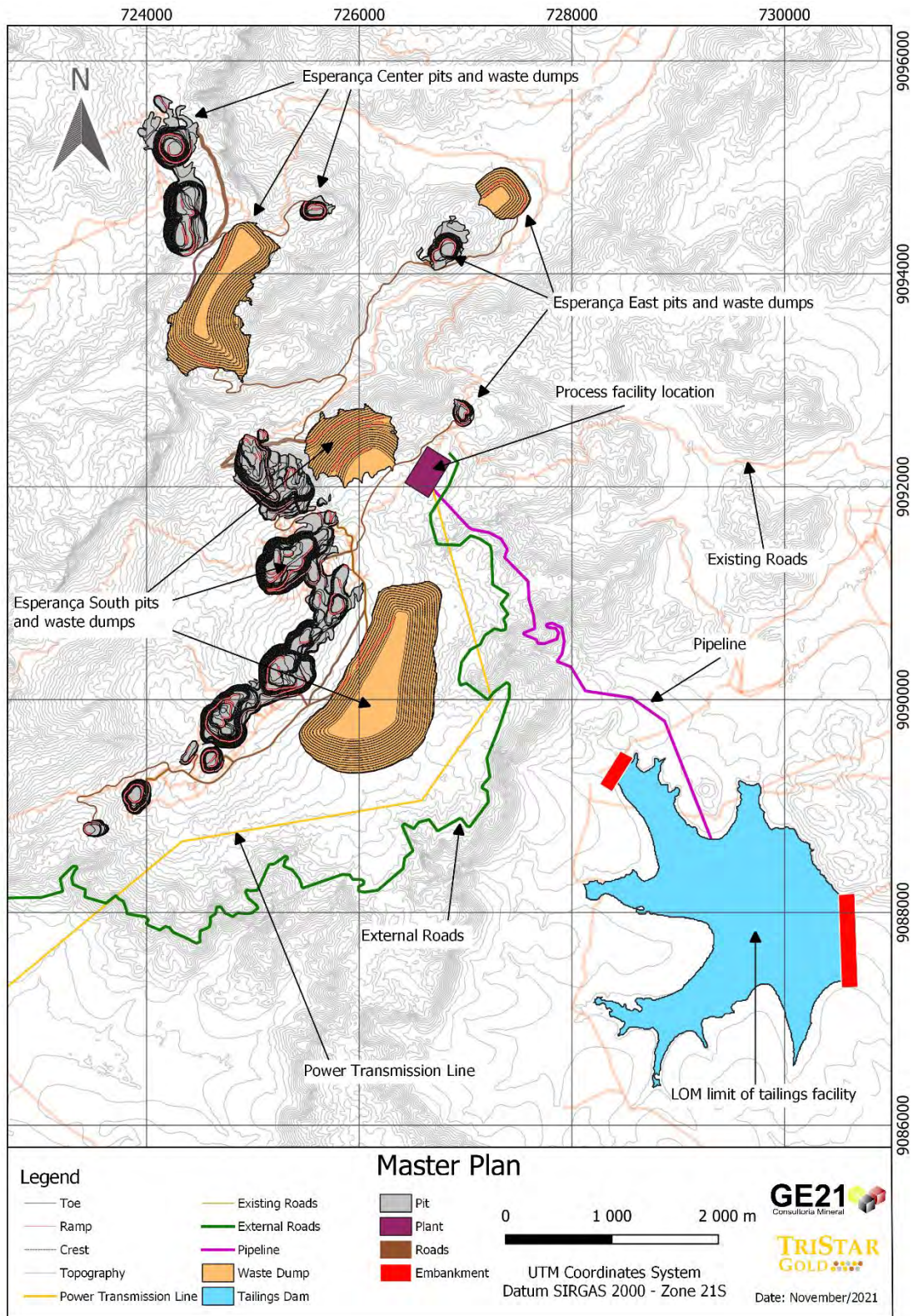

Figure 1-1: Project Layout

Pre-Feasibility Study**1.19 Market Studies and Contracts**

A formal gold market study was not developed for this technical report. For the Economic Model, GE21 used a gold price of \$1,550/oz based on recent gold projects Technical Reports.

1.20 Environmental Studies, Permitting and Social or Community Impact

For the four mineral concessions that hold all the current resources, the first phase of the permitting process began in 2020 with Pará State's environmental regulatory authority issuing Terms of Reference for the Environmental Impact Assessment (EIA). Year-long baseline studies began in 2020 and will continue through 2021 so that data can be acquired during the wet season and the dry season. Once the EIA studies have been completed, their findings will be compiled into a technical report and into a separate public consultancy report called the RIMA. These will be submitted to the state as part of the application for the first of three licenses required for constructing a mine.

1.21 Capital and Operating Costs

The present study estimated that the total CAPEX of the project would be \$261 million (including contingency). The OPEX of the process plant was estimated to be US\$ \$8.99/ton processed; mining was estimated to cost, via owner's fleet, \$1.66t/moved; and G&A costs were estimated to be \$ 5.7 million annually.

1.22 Economic Analysis

The discounted cash flow analysis developed in the pre-feasibility study estimated that at an annual discount rate of 5%: the project's post-tax NPV would be \$321 million; its post-tax IRR would be 28.0%, and its payback period 2.8 years. NPV_{5%} pre-tax would be \$399 million and its pre-tax IRR is estimated to be 32.7%.

1.23 Adjacent Properties

There are no properties immediately adjacent to the Castelo de Sonhos Project. Regionally the Palito Mine Complex, that belongs to Serabi Gold plc, is approximately 300km from Castelo de Sonhos Project produces about 40,000 /oz per annum.

1.24 Other Relevant Data and Information

All relevant data known to the Qualified Persons are reported in the according Sections. No other relevant data information must be disclosed.

1.25 Interpretation and Conclusions

This PFS is based on a combination of geological, geotechnical and metallurgical studies which, taken together, establish that gold production from Castelo de Sonhos is both technically and economically feasible.

GE21 received a resource model for the Castelo de Sonhos project from TriStar and independently assessed, validated and revised it to be used in the reserves estimate provided in this document. The new, current resource block model has most of the resource in the confidence level of Indicated

Pre-Feasibility Study

category. The QP. Leonardo de Moraes Soares considered the MIK method performed by CDS acceptable for application in the Mineral Resources Estimate.

The mine planning model adopted was considered as a “diluted” model, adding approximately 3.9% mass dilution and 4.5% grade dilution to the source model. GE21 developed appropriate parameters for pit optimization, in order to generate nested optimized pits that were then used as basis for interim and ultimate design pit.

The CDS processing plant will be fed with 3.65Mt of ROM/year with a gold production of 146 koz/year in Phase 1 (Years 1 through 6) and 91 koz/year in Phase 2 (Years 7 through 11).

Whole ore agitation leaching has been selected as the preferred process flowsheet for project development. The plant will include crushing, grinding, hybrid cyanidation and carbon in leach, carbon acid wash, pressure stripping, and thermal regeneration. Gold will be electrowon from loaded eluate. Metal deposited on stainless steel wool cathodes will be rinsed off, decanted and collected as “sludge” which will be dried and smelted to produce doré bars for shipment to third party refiners.

A Discounted Cash Flow scenario was developed to assess the project based on economic-financial parameters, on the results of the mine scheduling and on the Sustaining CAPEX and OPEX estimate.

The project estimates an NPV_(5%) for CDS of \$321 million.

1.26 Recommendations

GE21 recommends advancing the project to a feasibility study, which should consider the following recommendations

- Perform a confirmatory campaign of density test work to improve the density of information across the deposit, including in the friable upper arenite that will account for much of the stripping along the high walls of the open pits.
- Continue to expand the total mineral resource with:
 - holes that extend current resources into adjacent areas where the deposits remain open along strike and down-dip.
 - holes that test resource potential in the interior of the plateau, particularly at depths beyond the reach of open-pit operations.
 - holes that infill 100 m drilling to improve the classification of resources from Inferred to Indicated.
 - perform a study based on a local reduction of drilling grid size and update on geostatistical modelling to improve the classification of resources from Indicated to Measured.
- Calculate the moisture and blasted swell effect analyses for ore and waste.
- Refine a grade control program.

Pre-Feasibility Study

- Detail Geotechnical analysis including a geotechnical oriented diamond drilling campaign and logging, including sampling collecting for tensile, compressive and shear strength tests.
- Perform supplementary geotechnical investigations of planned infrastructure sites including at waste pile areas; supplementary geochemical tests (ARD); large-scale waste rock and tailings co-disposal stockpile field test.
- To implement the hydrological and hydrogeological studies for the next phases of the project.
- To conduct a quotation for mining equipment including a full services contract for corrective and preventive maintenance services, including the supply of parts. Caterpillar, Komatsu, Liebherr, Mercedes, Volvo and Scania suppliers could be asked to submit proposals.

An estimate for the costs of the recommended items is shown below:

- Swell effect analysis tests at an estimated cost of US\$ 20,000.
- 1000 test works for density determination at an estimated cost of US\$ 20,000.
- Hydrological and hydrogeological studies at an estimated cost of US\$ 300,000.
- 38,000 meters of a new drilling campaign for the improvement of geological and grade estimate at an estimated cost of US\$ 4,600,000.
- Prepare a Feasibility Study at an estimated cost of US\$ 800,000.

Pre-Feasibility Study**2 INTRODUCTION**

This report is a Pre-Feasibility Study of TriStar's Castelo de Sonhos Gold Project. A complementary drilling campaign was carried out between fall 2020 and 2021. Engineering studies for various aspects of the PFS incorporate the 2019-2021 drilling campaign that resulted in the completion of this Pre-feasibility study.

GE21 Consultoria Mineral and Piteau Associates were hired by TriStar, with the support of other engineering companies and consultants to complete a Pre-feasibility study (PFS) for the Castelo de Sonhos Gold Project. The project is located in Pará state approximately 851km south from the major town of Santarém and 918km from Cuiabá, capital city of Mato Grosso state.

Once in operation, Castelo de Sonhos Project will be an open pit gold mine with approximately annual plant feed of 3.6 Mtpa at daily rate of 10,000 t ore processed.

In 2018, a PEA was developed by GE21 Consultoria Mineral and since then a Mineral Resource update was presented in 2021 by the same company.

TriStar regards this new resource model as a revision of the interpretation of the stratigraphic and structural controls on mineralization mainly in Esperança South Target.

Mineral Reserves are presented in this report and are based on the following information:

- Information available for GE21 at the time of this study
- Assumptions, conditions, data, reports and other information supplied by TriStar and third parties

2.1 Qualifications, Experience, and Independence

GE21 is an independent mineral consulting firm based in Brazil formed by a team of professionals accredited by the Australian Institute of Geoscientists ("AIG") as Qualified Persons for declaration of Mineral Resources and Mineral Reserves in accordance with NI 43-101.

Each of the authors of this Report has the appropriate qualifications, experience, competence, and independence, to be considered as a Qualified Person ("QP"), as defined in NI 43-101. Neither GE21 nor the authors of this Report have or have had any material interest in TriStar Gold or related entities. The relationship with TriStar Gold is solely professional, acting as an independent consultant. Payment of service fees is not related to the results of this Report.

The Lead Qualified Person of this Report is Eng. Porfirio Cabaleiro Rodriguez, a mining engineer with over 43 years of experience in Mineral Resource and Mineral Reserve estimates. Eng. Rodriguez is a fellow of the Australian Institute of Geoscientists (FAIG).

Geologist Leonardo Moraes Soares, with over 19 years of experience in resource modelling and estimate. Geo. Soares is a member of the Australian Institute of Geoscientists (MAIG).

Pre-Feasibility Study

Mining Engineer Guilherme Gomides Ferreira with over 16 years experience in open mining with focus on mining planning (Pit’s optimization, mining scheduler and fleet), economics analysis, (CAPEX/OPEX, DCF), risk analysis, and Mineral Reserve estimates. Eng. Ferreira is a member of the Australian Institute of Geoscientists (MAIG).

Mining Engineer Ricardo Reis de Paula with over 35 years experience in open mining with focus on mining operations, feasibilities studies, audits of mineral resource and reserves, mineral exploration project management, mining project valuation, mine planning, and analysis of economic viability for many types of mineral deposits, including gold projects. Eng. De Paula is a member of the Australian Institute of Geoscientists (MAIG).

Dr. Martin Paul Boland is the Principal Hydrogeologist for Piteau Associates, holding a PhD in structural geology from Keele University, a Chartered Geologist and member of the Geological Society of London, with more than 30 years’ experience in the mining industry as consultant, technical director and operations manager with government bodies and consulting engineering firms that specialize in technical studies and audits of mineral exploration, groundwater and surface water management, water treatment and environmental impact assessment.

Civil Engineer Andries Jacobus Strauss is the Manager of Mine Residue Section for Knight Piésold (Pty) Ltd., a Member of South African Institute of Civil Engineers, with more than 20 years of experience in the industry, working at the Department of Water affairs, dealing with design and construction supervision of various water containment and conveyance structures throughout South Africa; and currently managing with the same consulting engineering firm that specializes in technical studies and audits of mine residue facilities.

Table 2-1 presents the summary information about QPs. The Qualified Person certificates are presented below.

Table 2-1 Qualified Persons

Company	Qualified Person	Site Visit	Responsibility
GE21	Porfirio Cabaleiro Rodriguez, FAIG	not inspected the property	Lead QP. Overall responsibility on behalf of GE21, as informed on following Certificate
GE21	Leonardo de Moraes Soares, MAIG	2 days duration in May 2021	Geological and geotechnical studies, as informed on following Certificate
GE21	Guilherme Gomides Ferreira, MAIG	2 days duration in May 2021	Mineral Reserves and Mine Planning, as informed on following Certificate
GE21	Ricardo Reis de Paula MAIG	not inspected the property	Mine Fleet, Mine Capital and Operating Costs, as informed on following Certificate
Piteau Associates	Martin Paul Boland	4 days duration in January 2020	Mine Dewatering, Hydrology and Water Supply, as informed on following Certificate
Knight Piésold	Andries Jacobus Strauss	not inspected the property	Tailing Storage Facility, as informed on following Certificate

Pre-Feasibility Study**QP CERTIFICATE OF PORFÍRIO CABALEIRO RODRIGUEZ**

- a) I, Porfírio Cabaleiro Rodriguez, am a Mining Engineer and Director for GE21 Consultoria Mineral, located at Avenida Afonso Pena, 3130 – 12º andar, Belo Horizonte, MG, Brazil, CEP 30.130-910.
- b) This certificate applies to the Technical Report entitled “Castelo de Sonhos Project Pre-Feasibility Study, Pará State, Brazil” with an effective date of October 4th, 2021.
- c) I hold the following academic qualifications: a B.A.Sc. in Mining Engineering from the Federal University of Minas Gerais, in Belo Horizonte, Brazil.
- d) I am a professional Mining Engineer, with more than 43 years of experience in the mining industry. My relevant experience for the purpose of this Technical Report includes:
- 1986 to 2015 – Consultant, manager, and director with consulting engineering firms that specialize in technical studies and audits of mineral resource and reserves, mine planning, geometallurgy, pit optimization, and analysis of economic viability for many types of mineral deposits, including gold projects in their exploration and development phases, as well as producing gold mines.
 - 2015 to present – Director of GE21 Consultoria Mineral, which provides advice, assistance, and audits for the entire mining cycle, from defining strategies, generating and selecting targets and investments, mineral exploration, project development, geological assessments, resource reserve estimation for JORC and NI 43-101 reports, conceptual technical and economic studies, and economic feasibility.

I am a member of the Australian Institute of Geoscientists (#3708).

I meet all the education, work experience, and professional registration requirements of a “Qualified Person” as defined in Section 1.1 of National Instrument 43-101.

- e) I have not inspected the property that is the subject of this Technical Report.
- f) I am solely responsible for Sections 13, 17, 19, 20, 22, 23, 24 and 27, and jointly responsible for Sections 1 through 10, 15, 16, 18, 21, 25 and 26 of this Technical Report.
- g) I am independent of the Issuer, TriStar Gold Inc.
- h) Previously, I have worked on the Preliminary Economic Assessment (PEA) for the property that is the subject of this Technical Report and served as a QP for the NI 43-101 report on that PEA.
- i) I have read National Instrument 43-101 and the parts of the Technical Report for which I am responsible have been prepared in compliance with this Instrument, including the CIM Definition Standards on Mineral Resources and Mineral Reserves.
- j) At the effective date of the Technical Report, and at the date it was filed, to the best of my knowledge, information, and belief, the parts of the Technical Report for which I am responsible contain all scientific and technical information that is required to be disclosed to make the Technical Report not misleading.



Porfírio Cabaleiro Rodriguez
FAIG 3708

Pre-Feasibility Study**QP CERTIFICATE OF GUILHERME GOMIDES FERREIRA**

- a) I, Guilherme Gomides Ferreira, am a Mining Engineer for GE21 Consultoria Mineral, located at Avenida Afonso Pena, 3130 – 12º andar, Belo Horizonte, MG, Brazil, CEP 30.130-910.
- b) This certificate applies to the Technical Report entitled “Castelo de Sonhos Project Pre-Feasibility Study, Pará State, Brazil” with an effective date of October 4th, 2021
- c) I hold the following academic qualifications: a B.A.Sc. in Mining Engineering from the Federal University of Minas Gerais, in Belo Horizonte, Brazil.
- d) I am a professional Mining Engineer, with more than 16 years of experience in the mining industry. My relevant experience for the purpose of this Technical Report includes:
- 2006 to 2017– Mining Engineer at mining companies, developing technical studies of Mineral Reserves, mine planning, pit optimization, and economic analysis as well a producing iron ore and gold mine.
 - 2017 to present – Manager of GE21 Consultoria Mineral, which provides advice, assistance, and audits for the entire mining cycle, from defining strategies, generating and selecting targets and investments, mineral exploration, project development, geological assessments, resource reserve estimation for JORC and NI 43-101 reports, conceptual technical and economic studies, and economic feasibility.

I am a member of the Australian Institute of Geoscientists (#7586).

I meet all the education, work experience, and professional registration requirements of a “Qualified Person” as defined in Section 1.1 of National Instrument 43-101.

- e) I inspected between 26th and 27th of May 2021 the property that is the subject of this Technical Report.
- f) I am jointly responsible for Sections 15, 16, 25 and 26 of this Technical Report.
- g) I am independent of the Issuer, TriStar Gold Inc.
- h) I have read National Instrument 43-101 and the parts of the Technical Report for which I am responsible have been prepared in compliance with this Instrument, including the CIM Definition Standards on Mineral Resources and Mineral Reserves.
- i) At the effective date of the Technical Report, and at the date it was filed, to the best of my knowledge, information, and belief, the parts of the Technical Report for which I am responsible contain all scientific and technical information that is required to be disclosed to make the Technical Report not misleading.



Guilherme Gomides Ferreira
MAIG 7586

Pre-Feasibility Study**QP CERTIFICATE OF LEONARDO DE MORAES SOARES**

- a) I, Leonardo de Moraes Soares, am a Geologist for GE21 Consultoria Mineral, located at Avenida Afonso Pena, 3130 – 12º andar, Belo Horizonte, MG, Brazil, CEP 30.130-910.
- b) This certificate applies to the Technical Report entitled “Castelo de Sonhos Project Pre-Feasibility Study, Pará State, Brazil” with an effective date of October 4th, 2021.
- c) I hold the following academic qualifications: a B.A.Sc. in Geology from the Federal University of Minas Gerais, in Belo Horizonte, Brazil.
- d) I am a professional geologist, with more than 19 years of experience in the mining industry. My relevant experience for the purpose of this Technical Report includes:
- 2002 to 2008 and 2010 – Geologist at gold mining companies, developing technical studies of exploration, open pit and underground grade control and geomechanics and mine planning as well a gold mine.
 - 2009 and 2011 to 2017 – Geologist at Coffey Mining consulting company as mineral resource geologist for several projects, mainly in gold mining projects.
 - 2018 to present – Manager of GE21 Consultoria Mineral, which provides advice, assistance, and audits for the entire mining cycle, from defining strategies, generating and selecting targets and investments, mineral exploration, project development, geological assessments, resource reserve estimation for JORC and NI 43-101 reports, conceptual technical and economic studies, and economic feasibility.

I am a member of the Australian Institute of Geoscientists (#5180).

I meet all the education, work experience, and professional registration requirements of a “Qualified Person” as defined in Section 1.1 of National Instrument 43-101.

- e) I inspected between 26th and 27th of May 2021 the property that is the subject of this Technical Report.
- f) I am solely responsible for Sections 11, 12 and 14, and jointly responsible for Sections 1 through 10, 16, 25 and 26 of this Technical Report.
- g) I am independent of the Issuer, TriStar Gold Inc.
- h) I have read National Instrument 43-101 and the parts of the Technical Report for which I am responsible have been prepared in compliance with this Instrument, including the CIM Definition Standards on Mineral Resources and Mineral Reserves.
- i) At the effective date of the Technical Report, and at the date it was filed, to the best of my knowledge, information, and belief, the parts of the Technical Report for which I am responsible contain all scientific and technical information that is required to be disclosed to make the Technical Report not misleading.

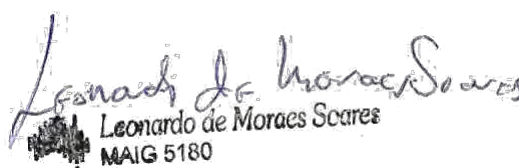

Leonardo de Moraes Soares
MAIG 5180

Pre-Feasibility Study**QP CERTIFICATE OF RICARDO REIS DE PAULA**

- a) I, Ricardo Reis de Paula, am a Mining Engineer and Director for GE21 Consultoria Mineral, located at Avenida Afonso Pena, 3130 – 12º andar, Belo Horizonte, MG, Brazil, CEP 30.130-910.
- b) This certificate applies to the Technical Report entitled “Castelo de Sonhos Project Pre-Feasibility Study, Pará State, Brazil” with an effective date of October 4th, 2021.
- c) I hold the following academic qualifications: a B.A.Sc. in Mining Engineering from the Federal University of Minas Gerais, in Belo Horizonte, Brazil, Post Graduate degree in Operational Geostatistics at Federal University of Ouro Preto (UFOP) and MBA in Business Management at Getúlio Vargas Foundation (FGV). All of them in Brazil.
- d) I am a professional Mining Engineer, with more than 35 years of experience in the mining industry. My relevant experience for the purpose of this Technical Report includes:
- 1986 to 2019 –Projects implementation and management of mining operations including implementation from the Geological Research to the Construction, Assembly, Startup, and Operations. I have experience in, mining operations, feasibilities studies, audits of Mineral Resource and Mineral Reserves, fleet sizing, economic analysis many types of mineral deposits, including gold projects.
 - 2019 to present – Mining Engineer at GE21 Consultoria Mineral, which provides advice, and audits for the entire mining cycle, from defining strategies, generating and selecting targets and investments, mineral exploration, project development, geological assessments, resource reserve estimation for JORC and NI 43-101 reports, conceptual technical and economic studies, and economic feasibility.

I am a member of the Australian Institute of Geoscientists (#8094).

I meet all the education, work experience, and professional registration requirements of a “Qualified Person” as defined in Section 1.1 of National Instrument 43-101.

- e) I have not inspected the property that is the subject of this Technical Report.
- f) I am jointly responsible for Sections 16, 21, 25 and 26 of this Technical Report.
- g) I am independent of the Issuer, TriStar Gold Inc.
- h) I have not had prior involvement with the property that is the subject of the Technical Report.
- i) I have read National Instrument 43-101 and the parts of the Technical Report for which I am responsible have been prepared in compliance with this Instrument, including the CIM Definition Standards on Mineral Resources and Mineral Reserves.
- j) At the effective date of the Technical Report, and at the date it was filed, to the best of my knowledge, information, and belief, the parts of the Technical Report for which I am responsible contain all scientific and technical information that is required to be disclosed to make the Technical Report not misleading.



QP CERTIFICATE OF ANDRIES JACOBUS STRAUSS

- a) I, Andries Jacobus Strauss, am a Civil Engineer and Manage the Mine Residue Section for Knight Piésold (Pty) Ltd, located at 1 Discovery Place, Sandhurst, Sandton, South Africa.
- b) This certificate applies to the Technical Report entitled “Castelo de Sonhos Project, Pre-Feasibility study, Castelo de Sonhos District, Pará State, Brazil” with an effective date of October 4, 2021.
- c) I hold the following academic qualifications: a B.Eng. in Civil Engineering from the University of Pretoria, in Pretoria, South Africa.

I am registered as a Professional Civil Engineer with the Engineering Council of South Africa (#20090268), with more than 20 years of experience in the industry. My relevant experience for the purpose of this Technical Report includes:

- 2000 to 2004 – Engineer with the Department of Water affairs, Earth and Rockfill Dams Section, dealing with design and construction supervision of various water containment and conveyance structures throughout South Africa.
- 2004 – current – Engineer and Manager with the same consulting engineering firm that specializes in technical studies and audits of mine residue facilities for many types of mineral deposits, across the full life cycle of these facilities.

I am a member of the South African Institute of Civil Engineers (#2009079).

I meet all the education, work experience, and professional registration requirements of a “Qualified Person” as defined in Section 1.1 of National Instrument 43-101.

- d) I have not inspected the property that is the subject of this Technical Report.
- e) I am solely responsible for Section 18.3 of this Technical Report.
- f) I am independent of the Issuer, TriStar Gold Inc.
- g) I have no previous involvement in this project.
- h) I have read National Instrument 43-101 and the parts of the Technical Report for which I am responsible have been prepared in compliance with this Instrument, including the CIM Definition Standards on Mineral Resources and Mineral Reserves.
- i) At the effective date of the Technical Report, and at the date it was filed, to the best of my knowledge, information, and belief, the parts of the Technical Report for which I am responsible contain all scientific and technical information that is required to be disclosed to make the Technical Report not misleading.

Signed and sealed, on 19th November 2021.



QP CERTIFICATE OF DR. MARTIN PAUL BOLAND

- a) I, Martin Paul Boland, am a Principal Hydrogeologist for Piteau Associates, located at Canon Court West, Abbey Lawn, Shrewsbury, Shropshire, UK, SY2 5DE.
- b) This certificate applies to the Technical Report entitled "Castelo de Sonhos Project Pre-Feasibility Study, Pará State, Brazil with an effective date of October 4th, 2021.
- c) I hold the following academic qualifications: a B.A. in Natural Sciences (Geology) from Trinity College Dublin, an MSc in Hydrogeology from University College London and a PhD in structural geology from Keele University.
- d) I am a professional Hydrogeologist, with more than 30 years' experience in the mining industry.
- e) My relevant experience for the purpose of this Technical Report includes:
 - 1989 to 2021 – Consultant, Technical Director and Operations Manager with government bodies and consulting engineering firms that specialize in technical studies and audits of mineral exploration, groundwater and surface water management, water treatment and environmental impact assessment for all stages of project development from exploration, through feasibility to operation and closure. These studies have been undertaken for a range of mineral commodities, including producing gold mines.
- f) I am a Chartered Geologist and member of the Geological Society of London.
- g) I meet all the educational, work experience and professional registration requirements of a "Qualified Person" as defined in Section 1.1 of National Instrument 43-101.
- h) I inspected between 21st and 24th of January 2020 the property that is the subject of this Technical Report.
- i) I am solely responsible for Subsections 16.9, 18.5.1 and 18.5.3, together with review of this Technical Report.
- j) I am independent of the Issuer, TriStar Gold Inc.
- k) I have read National Instrument 43-101 and the parts of the Technical Report for which I am responsible have been prepared in compliance with this Instrument, including the CIM Definition Standards on Mineral Resources and Mineral Reserves.
- l) At the effective date of the Technical Report, and at the date it was filed, to the best of my knowledge, information, and belief, the parts of the Technical Report for which I am responsible contain all scientific and technical information that is required to be disclosed to make the Technical Report not misleading.

Signed and sealed in Shrewsbury, UK, on 19th November 2021.

Martin Boland

19th November 2021



PITEAU ASSOCIATES (UK)
Company
No. 10436917
LIMITED

Pre-Feasibility Study

2.2 Effective Date

Mineral Resources and Mineral Reserves estimate for the Castelo de Sonhos gold project has an effective date of October 4th, 2021.

Pre-Feasibility Study**3 RELIANCE ON OTHER EXPERTS**

On issues related to ownership and mineral concession rights, the authors rely on legal opinions given to the Company by its Brazilian lawyers, namely that the Company does have 100% ownership of the Castelo de Sonhos Project through its Brazilian subsidiary, and that its mineral concession rights are in good standing with the *Agência Nacional de Mineração* (ANM), the Brazilian federal agency that regulates and oversees mining. GE21's Lead QP Porfírio Cabaleiro Rodriguez verified on ANM's online platform that status of each of the six Mineral Concessions is in accordance with the information in Section 4 of this Report.

On issues related to environmental permitting and studies, taxation and royalties, the authors rely on the information provided by TriStar.

Pre-Feasibility Study

4 PROPERTY DESCRIPTION AND LOCATION

4.1 Location

The Castelo de Sonhos Gold Project is in south-western Pará State, Brazil, approximately 20km north-east of the town of Castelo de Sonhos (Figure 4-1), which lies on the main north-south BR-163 highway that links Cuiabá, a major business city with a population of two million, and Santarém, an important port city on the Tapajós River. The Project area is centered approximately at 8°12'07" south, 54°59'20" west.



Figure 4-1 The location of the Project in Brazil

Pre-Feasibility Study

4.2 Mining Legislation, Administration and Rights

When TriStar was created in 2010, mining activity in Brazil was regulated by the *Departamento Nacional de Produção Mineral* (DNPM). In a major consolidation and updating of mining law in 2018, a new federal agency, the *Agência Nacional de Mineração* (ANM), was created. The procedures for applying for mineral concession rights and for maintaining them in good standing are largely unchanged from the DNPM era to the ANM era. The following summary of the main steps refers to ANM even though the original applications were made to DNPM.

- The entity (an individual or a corporation) makes an application to ANM for the right to conduct mineral exploration activities in a specified area. If the area has no previous applicant, the new entity has priority during the review period.
- If it finds the application acceptable, ANM grants an exploration permit that gives the entity three years to conduct mineral exploration studies.
- Before the three-year permit expires, the entity must file either a Partial Exploration Report or a Final Exploration Report. Filing a Partial Exploration Report allows the entity to request a three-year extension of the exploration permit. If this request is approved by ANM, the entity must submit the Final Exploration Report within the three-year extension period. In addition to presenting results, analysis and interpretations from the mineral exploration studies, a Final Exploration Report must also reach a conclusion on whether the studies were positive (if mineralization with an economic value has been found) or negative (no success was obtained in the work).
- When a positive Final Exploration Report is approved by the ANM, a corporate entity has one year to file a *Plano de Aproveitamento Econômico* (PAE) that demonstrates that the project is technically and economically viable, and that presents an implementation plan. The PAE period may be extended through a request to the ANM.
- Once the ANM has approved the PAE, the Minister of Mines and Energy grants a mining permit. The company must start the implementation plan within six months. There is no fixed time period for a mining permit, which remains valid as long as the company continues to follow the implementation plan or has ANM's approval for changes and continues to meet the permitting and reporting requirements of state and federal agencies responsible for the environment, sustainability and community development.

4.3 Mineral Concessions

The Castelo de Sonhos Gold Project spans six contiguous mineral claims (Figure 4-2) with a combined total area of 17,177 ha. TriStar Mineração do Brasil Ltda, a Brazilian company 100% controlled by TriStar, holds the title on all six claims.

Most of the gold resources on the Castelo de Sonhos plateau lie on the mineral concession shown as #1 on Figure 4-2 (claim number 850.329/2002), which had its final positive exploration report approved by the ANM on 17th April 2017 and is now in the environmental study phase.

Pre-Feasibility Study

For the concession shown as #2 (850.391/2016), the partial exploration report has been submitted and is awaiting approval. The final exploration report is due to 2024.

Concessions #3 (850.310/2011), #4 (850.309/2011) and #5 (850.784/2009) had their final exploration reports filed on 24th August 2017 and are now in the environmental study phase.

TriStar was officially granted the concession marked as #6 (850.775/2020) in June 2020, it has until 2023 to submit the partial exploration report.

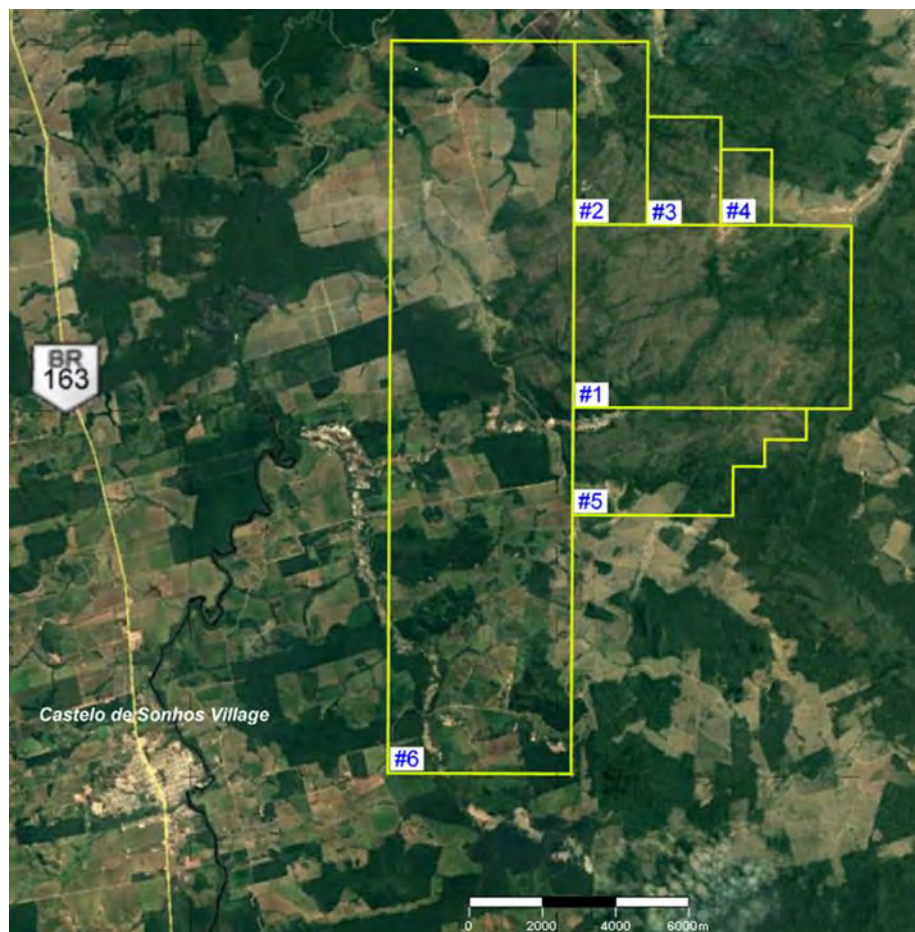

Figure 4-2 Mineral concessions for the Project area are shown by yellow outline.

4.4 Coordinate System

Historically, all survey data for the project were acquired in UTM coordinates using the SAD69 datum. In 2017, the Brazilian government mandated the use of SIRGAS 2000 coordinates for all federal government reports, a directive that covers reports provided to the federal ANM, which regulates mining activity in Brazil.

In late 2020, TriStar migrated to the SIRGAS 2000 coordinate system for all data collection while also retaining UTM/SAD69 coordinates in its databases for historical harmonization.

Pre-Feasibility Study

5 ACCESSIBILITY, CLIMATE, LOCAL RESOURCES, INFRASTRUCTURE, AND PHYSIOGRAPHY

5.1 Accessibility

The Project site is accessible year-round by dirt road from the village of Castelo de Sonhos which lies on BR-163, the paved federal highway that connects Cuiabá, the capital of Mato Grosso State, to Santarém, a port city on the Tapajós River, 850 km to the north. During the rainy season, the most direct route to BR-163 is sometimes impassable at bridges covered by floodwater, but the site can still be reached by a longer and more circuitous route.

The 550m airstrip at the Castelo de Sonhos field camp (Figure 5-1) makes the site directly accessible by small aircraft from cities served by commercial airlines, like Alta Floresta (a 50-minute flight) or Sinop (a 90-minute flight). Larger airplanes can land at the 1,100m runway at the village of Castelo de Sonhos.



Figure 5-1 Image taken from a drone showing the airstrip located in Esperança Center, with camp buildings in the background.

5.2 Climate

The region has a tropical monsoon climate, with most of its annual rainfall of about 2,000mm falling during the December–May rainy season, and average daily temperatures higher than 24°C all year (Figure 5-2).

Pre-Feasibility Study

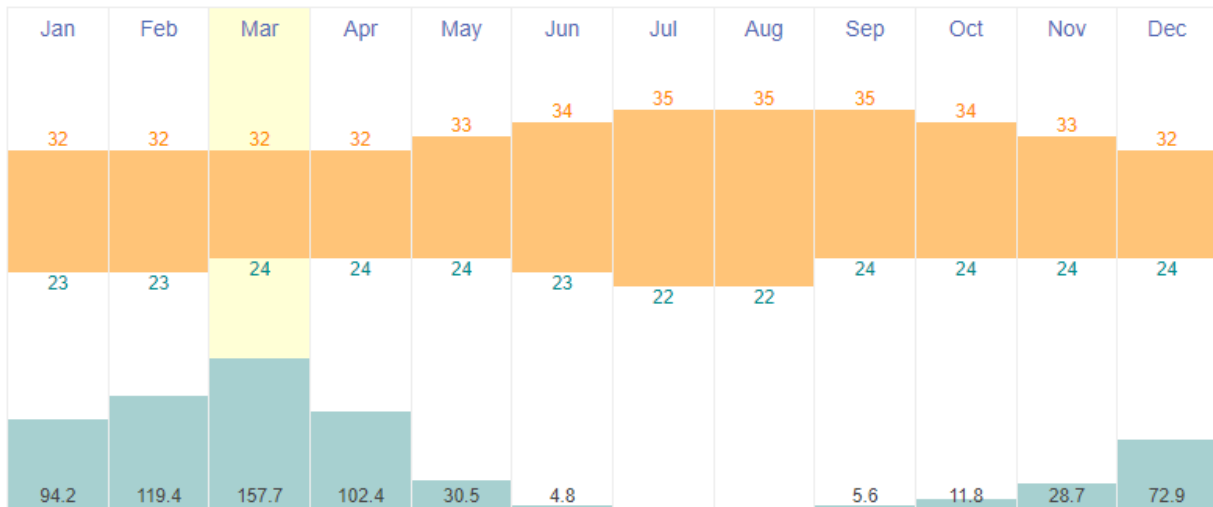

Figure 5-2 Variations in average daily temperature highs and lows (orange graph in degrees Celsius) and total monthly rainfall (teal graph in millimeters), from 1985 to 2015 for southern Pará State (Source: <https://www.timeanddate.com/weather/@6319433/climate>).

Mineral exploration may be conducted year-round. The Project location on the plateau with its good drainage minimizes the effect of the rainy season, although lightning strikes on the plateau do occasionally bring field activities to an end in the late afternoon. Elsewhere in the region, producing mines can operate year-round with supporting infrastructure.

In October 2020 TriStar installed an active weather station on the plateau to gather data on local temperature, average wind direction, humidity, and pressure as part of its environmental baseline monitoring program. Every 15 minutes the weather station automatically uploads data to the WeatherLink Cloud through a Bluetooth connection.

5.3 Geomorphology

The Castelo de Sonhos deposit sits on an incised plateau that rises several hundred meters above the plains and grasslands around the Rio Curuá, which runs west of the plateau, and its tributaries to the east.

The plains have an average elevation of approximately 250m above sea level while the plateau itself is approximately 550m above sea level. The contrasting elevation between the plateau and the surrounding plains is a result of higher resistance to erosion of the silicified arenites and conglomerates on the plateau.

The vegetation on the plateau is mostly South American savanna: small trees, bushes and grasses growing on rocky soil; taller trees can be found in drainages. On the surrounding plains, the vegetation is grasslands that were cleared for farming and cattle ranching.

5.4 Local Resources and Infrastructure

The village of Castelo de Sonhos (Figure 5-3) has banks, telecommunications, mail, medical services, police, supermarkets, restaurants, and hotels. It also has businesses able to service and repair heavy equipment and machinery; these began when the village was a center of logging activity and have

Pre-Feasibility Study

continued to the present because the village is a major pit stop for the heavy trucks that haul soy from Mato Grosso State to the Amazon along BR-163.



Figure 5-3 Panoramic view of the village of Castelo de Sonhos, looking north along highway BR-163.

Given the mining history of Pará State and the country in general, skilled and unskilled exploration and mining personnel are available in the region. Pará State has two universities with geology and mining education programs: the Federal University of Pará with its main campus in Belém, and the Federal University of Southern and Southeastern Pará in Marabá; both of these universities have several satellite campuses, including in Altamira, the large municipality in which Castelo de Sonhos lies.

A 138kV powerline runs along BR-163, bringing power from three small hydroelectric plants on the Curuá and Três de Maio rivers near the southern border of Pará State, where the drop from the Serra do Cachimbo plateau creates many waterfalls.

In southern Pará State, the primary source of income is farming (soy, sugarcane, fruit) or cattle ranching. In 2018, TriStar worked together with local farmers to fund the construction of a spur from the main powerline on BR-163 to farms that flank the plateau and up to TriStar's camp in Esperança Center. The camp can also meet all its current electricity needs from a diesel generator.

There is a satellite telephone at the TriStar camp, along with high-speed internet that provides excellent communication. A Wi-Fi tower located in Esperança South enables voice-over-IP (VoIP) communications. A shortwave radio system provides voice communication within the project area.

The camp has sufficient space to house up to 30 people, including professional staff, technicians, contractors, visiting consultants and workers from the nearby village. The local worker's staff a small kitchen and dining hall, provide cleaning services and run the camp laundry.

There is abundant water, all of it potable, on the Castelo de Sonhos plateau, in many creeks and streams that flow year-round. A well provides the camp with water for drinking, cooking, and cleaning. Septic tanks and a leach field provide for sewage waste disposal.

Pre-Feasibility Study

The camp also has office space that accommodates up to 10 people; facilities for sawing diamond drill core and for logging and photographing core samples and RC chips; and a core storage area that can store 25,000m of core and 44,000m of RC chips.

Pre-Feasibility Study

6 HISTORY

6.1 History of Exploration

The Castelo de Sonhos Gold Project lies along the southeastern edge of the Tapajós gold province, the region where the biggest gold rush in Brazil's history occurred.

From the 1960s to the mid-1990s, hundreds of thousands of artisanal miners, garimpeiros, (Figure 6-1) mined 16–30Moz of gold in a vast swath of south-western Pará State. In the Castelo de Sonhos area, an estimated 300,000oz of gold were mined in small-scale operations, garimpos, that targeted the gravels in rivers and creeks that drain the plateau.

Eventually, the declining price of gold in the 1990s ended this period of prosperous gold mining for the garimpeiros.



Figure 6-1 Artisanal miners or garimpeiros (left) and abandoned excavations or garimpos (right) at Castelo de Sonhos Gold Project.

6.2 History of Mineral Tenure

By the mid-1990s, the region had gained the interest of major mining companies and from 1995 to 1997 Barrick Gold held the title for the mineral claims on the plateau. Although their exploration program confirmed that the source of gold for the surrounding alluvial deposits was the silicified conglomerates on the plateau, Barrick Gold ultimately decided to relinquish the project in 1997.

When Barrick left in 1997, garimpeiros began developing trenches, pits and small tunnels in and around the areas where Barrick had drilled (Figure 6-2). Although hand-dug, these surface workings were extensive and continuous, eventually spanning several kilometres of the conglomerate outcrop.

Pre-Feasibility Study

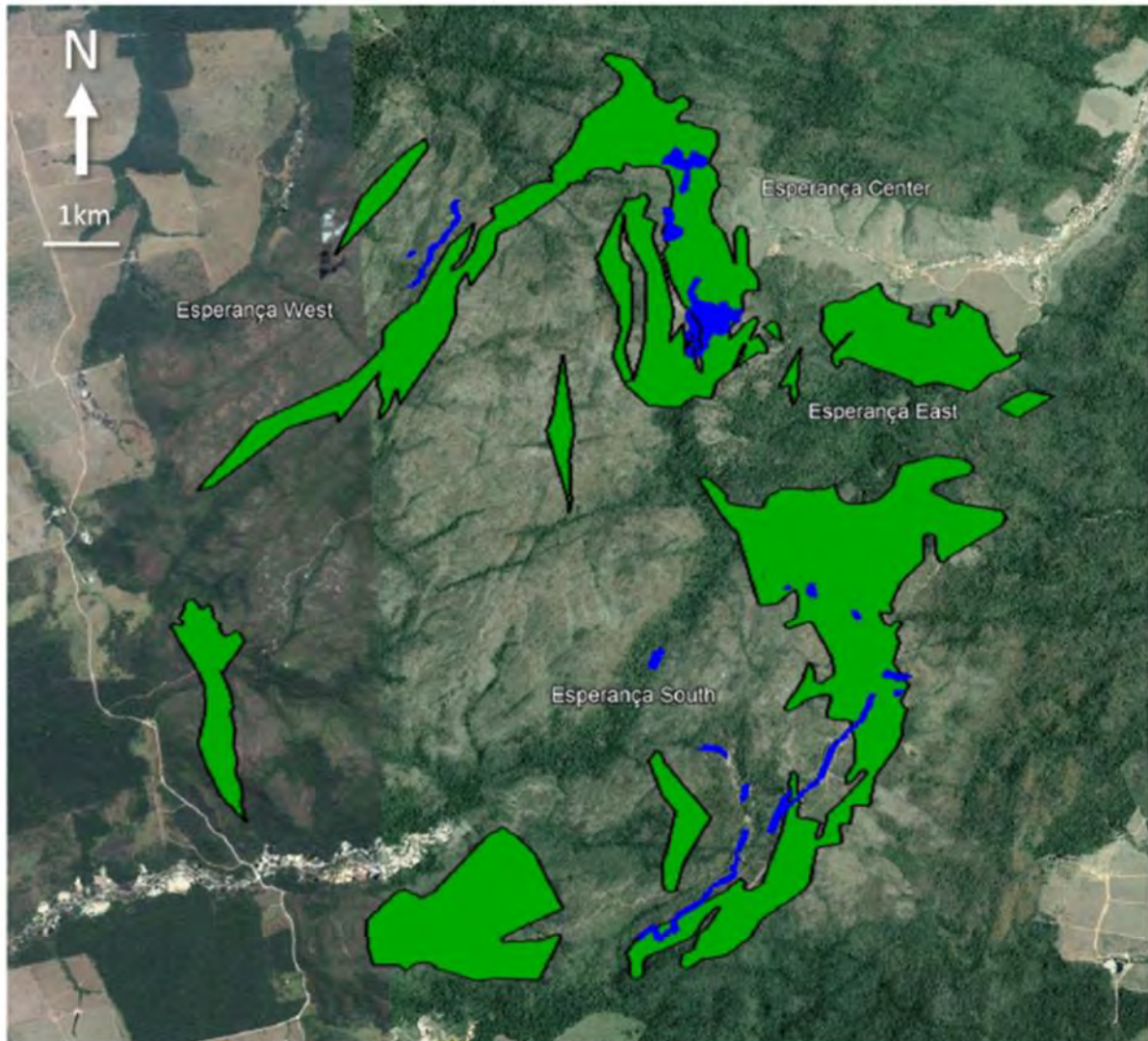

Figure 6-2 Plan map showing the continuity of the hand-dug garimpos (in blue) mirroring the mineralized conglomerate band outcrop (in green).

Limited by the increasing difficulty of extracting the gold from the hard rock without the use of explosives and mechanized equipment, and by the difficulty of dewatering the trenches, pits and tunnels, the number of garimpeiros has dwindled to a few part-time solo operators today.

From 2004 to 2009, Osisko Brasil Mineração Ltda (Osisko) held the title for the mineral claims on the plateau without doing any new exploration. Control of Castelo de Sonhos was passed to the Brazilian property owner when Osisko left Brazil in 2009.

In 2010, TriStar Mineração do Brasil Ltda, a wholly owned subsidiary of TriStar, signed an option contract with then property owner, Mr. João Américo França Vieira.

Following TriStar's airborne geophysical survey and the soil geochemistry study, six of the original Osisko claims were identified as having little or no potential and were returned to the ANM.

Pre-Feasibility Study**6.3 Property Results – Previous Owners**

Barrick (1995–1997) spent over \$1.5 million in exploration work that included soil geochemistry, stream sediment sampling, surveying, geophysical surveying, trenching and 23 diamond drillholes totaling approximately 2,027m.

It was during this phase of exploration when the two significant gold-bearing zones, Esperança South and Esperança Center, were identified.

In Esperança South, Barrick's geochemical survey defined a gold-in-soil anomaly approximately 5km long and 1–2km wide, defined by a 30ppb threshold. The Esperança Center anomaly measured approximately 2.6km x 500m as defined by a 150ppb Au threshold. The gold values found in the soil ranged from zero to 1,722ppb Au. Both areas had coincident magnetic and radiometric anomalies.

Barrick's work was concentrated on the Esperança South target. Most of the Esperança South trenching (total of over 4,700m) and drilling (15 drillholes totaling 1,448m) focused on a 2.5 km segment of the anomaly. One hole (160m) was drilled in the Esperança Center anomaly, and seven holes (418m) were drilled at the southern end of the Esperança East anomaly. Although many of Barrick's trench and soil samples produced assays below the detection limit, many of them were well mineralized, with grades reaching 18g/t both in drillhole samples and in trench samples. All of Barrick's trenches in the conglomerate outcrop produced consecutive runs of samples above 0.5g/t, with the horizontal lengths of these well-mineralized composites ranging from 4m to 77m. All of Barrick's drillholes that encountered a significant length of conglomerates also encountered mineralization above 0.5g/t. The only Barrick trenches and/or holes that did not encounter mineralization were those that did not target the conglomerates.

6.4 History of Resource Estimation**6.4.1 2004 Historical Resource Estimate (not compliant with NI 43-101)**

A July 2004 Osisko report on Castelo de Sonhos included earlier undated work by João Batista Teixeira that summarized the project's gold potential as falling into one of three types: "tailings from the alluvial gold deposits mined by garimpeiros, supergene enriched gold mineralization and primary gold mineralization, probably occurring at depth." Teixeira provided semiquantitative estimates of the total gold, using simple assessments of volume, tonnes and average grade that led to the conclusion that approximately 900,000oz of gold may be present in all three categories.

The historical estimate included only an estimate of contained metal, without any form or resource classification. The assumptions, parameters and methods used to prepare the resource estimate are unknown. The reader is cautioned that these resource estimates do not comply with the resource classifications approved by the Canadian Institute of Mining, Metallurgy and Petroleum (CIM) in their document "CIM Definition Standards on Mineral Resources and Mineral Reserves (2014)" because they have not been classified; the cut-off is not stated (but appears to be 0g/t); their geographic location is undocumented, and there was no Qualified Person identified. The authors and TriStar have no basis upon which to assess the reliability of the resource estimate.

Pre-Feasibility Study

The historical estimate has not been considered in any of TriStar's plans for project development. A Qualified Person has not done sufficient work to classify the historical estimate as a current resource estimate. No attempt has been made to identify the steps required to make this historic resource compliant with the resource classifications approved by the CIM since the historical estimate was not the basis for any subsequent mineral resource estimate.

6.4.2 2014 Historical Resource Estimate

The 2014 drillhole database consisted of 143 holes drilled by TriStar and two by Barrick. Three dimensional (3D) wireframes of the mineralization were developed from cross-sections, guided by assay grades and the general dip of the stratigraphy. Gold grades were estimated for 5m x 5m x 2m blocks. Ordinary kriging was used to interpolate grades of 2m composites that had been capped at 10g/t. Classification of the estimated resources into "Indicated" and "Inferred" categories were based on drillhole spacing, with the 50m x 50m drilling in Esperança South being sufficient for "Indicated" resources. None of the blocks in either of the block models was classified as "Measured". Resources were reported inside a pit shell to ensure that the resources had reasonable prospects for economic extraction. Although the block models contain grade estimates for blocks outside the pit shells, these blocks are not included in the resource inventory. Because this resource estimate relied on drillhole data, both for grade interpolation and development of wireframes, it was necessarily restricted to the areas that had been drilled by 2014, which covered only about 4.5km of the total of 16km of the mineralized outcrop. Because it was reported inside a pit shell that reached a depth of only 70m, it was restricted to near-surface mineralization.

6.4.3 2017 Historical Resource Estimate

The 2017 drillhole database consisted of 240 drillholes. Gold grades were estimated using uniform conditioned (UC) estimation, with 30x30x6m panels and 5x5x2m selective mining units within the panels. The UC estimates of the SMU distribution of grades within a panel were based on 1 m composites that had been capped at 20g/t. The capping value was deduced from cumulative distribution functions (CDF) and from Au grades sorted in ascending order. All resources above a depth of 120m below ground surface, inside the conglomerate band, and within 100m from drillholes were classified as "Inferred", no resources were classified as "Measured" or "Indicated". The choice of using 120m below ground surface as a base for the mineralization was based on the very strong similarities between geological, mineralogical, mining, and metallurgical characteristics between Tarkwa and Castelo de Sonhos and the fact that the Tarkwa pits reach depths greater than 120m below the original ground surface lends validity to the assumption that mineral resources at Castelo de Sonhos have reasonable prospects for eventual economic extraction to a depth of 120m.

6.4.4 2018 Historical Resource Estimate

At the time of the 2018 PEA, 163 diamond holes (19,973m) and 167 RC (18,991m) holes had been drilled. The 2018 resource estimate covered the three main areas with drilling: Esperança South (ES), Esperança Center (EC) and Esperança East (EE).

3D models of the hanging-wall (HW) and footwall (FW) of the conglomerate band were created that honour:

Pre-Feasibility Study

- Locations of contacts as mapped on the ground surface,
- Field measurements of bedding strike and dip,
- Contacts in drillholes, and
- Minimum curvature.

The wireframes of the 3D geometry of the conglomeratic band allowed the elevation, Z, at any location to be positioned stratigraphically by calculating its relative position between the footwall and hanging wall. The 2018 resource estimate recognized two stratigraphically conformable reefs where the average gold grade consistently exceeded 0.1g/t and where the average at that stratigraphic elevation over the entire deposit exceeded the marginal cut-off.

The two reefs separated the deposits into five domains. With some gold mineralization at the base of the upper arenite, the top of Domain 1 was not at the hanging wall of the conglomeratic band. Instead, the CGL-HW wireframe served as a soft boundary as did the bottom of domain 5 at the footwall of the conglomeratic band.

The contacts of the upper and lower reef served as hard boundaries. Samples inside the reefs were not used for grade estimation in any blocks outside the reefs, and vice versa.

A single block model was constructed for the entire project with all three targets. Block size was defined as 5m x 5m x 2m. 2.68 t/m³ was used as the dry bulk density for all mineral resource blocks; this value was the average of 28 measurements of dry bulk density done by GE21. Gold grades were interpolated by ID3 weighting, directly from assays, with the ID3 weight being multiplied by the sample length. The interpolation was done in a single pass, using a quadrant search strategy. For the two reef domains (2 and 4), the long radius was 150m and the short radius was 15m. For the non-reef domains (1, 3 and 5), the long radius was 100m and the short radius was 10m. All assays were capped at 10 g/t.

Pre-Feasibility Study

6.4.5 2021 Historical Resource Estimate

6.4.5.1 Resource Estimation

**Table 6-1 Mineral resource estimate for the Castelo de Sonhos gold project (with an effective date of December 31, 2020) above a reporting cut-off of 0.3 g/t Au.
The Qualified Person is TriStar's Vice President Mo Srivastava.**

Region	Classification	Tonnage (Mt)	Grade (g/t Au)	Metal Content ³ (Moz Au)
Esperança South	Indicated	24.5	1.3	1.1
	Inferred	10.4	1.1	0.4
Esperança East	Indicated	2.4	1.1	0.1
	Inferred	9.4	0.9	0.3
Esperança Center	Indicated	13.1	0.8	0.3
	Inferred	2.4	0.9	0.1
Project Total	Indicated	40.1	1.2	1.5
	Inferred	22.2	1.0	0.7

¹Project totals may appear not to sum correctly since all numbers have been rounded to reflect the precision of Inferred and Indicated mineral resource estimates.

²The reporting cut-off corresponds to the marginal cut-off grade for an open pit with processing + G&A cost of \$US 12/t, metallurgical recovery of 98% and a gold price of \$US 1,250/oz. To meet the requirement of "reasonable prospect for eventual economic extraction" the mineral resources must also fall within a bounding pit shell with 55° walls. These are mineral resources and not reserves and as such do not have demonstrated economic viability.

³The metal content estimates reflect gold in situ, and do not include factors such as external dilution, mining losses and process recovery losses.

⁴TriStar is not aware of any environmental, permitting, legal, title, taxation, socio-economic, marketing or political factors that might materially affect these mineral resource estimates.

6.4.5.2 Database

The drillhole collar database used for the model is the one available at the end of January 2021, at which point in time assays were available for all reverse circulation holes up through RC-20-550 and for all diamond drillholes up through CSH-20-491.

6.4.5.3 Geological Model

Shown in Figure 6-3 is an example of the litho-geochemical units and erosional surfaces on a cross-section interpreted with the help of GoldSpot Discoveries. Across the entire plateau, 15 units were interpreted and rendered as wire-framed solids. Some of these are sedimentary units that run sub-parallel to the bowl-shaped stratigraphy of the plateau's meta-sediments. Others do not run parallel to the general bedding direction; instead, they are non-sedimentary rocks that cut across the stratigraphy. These were grouped into seven domains, separated by two erosional unconformities.

Pre-Feasibility Study

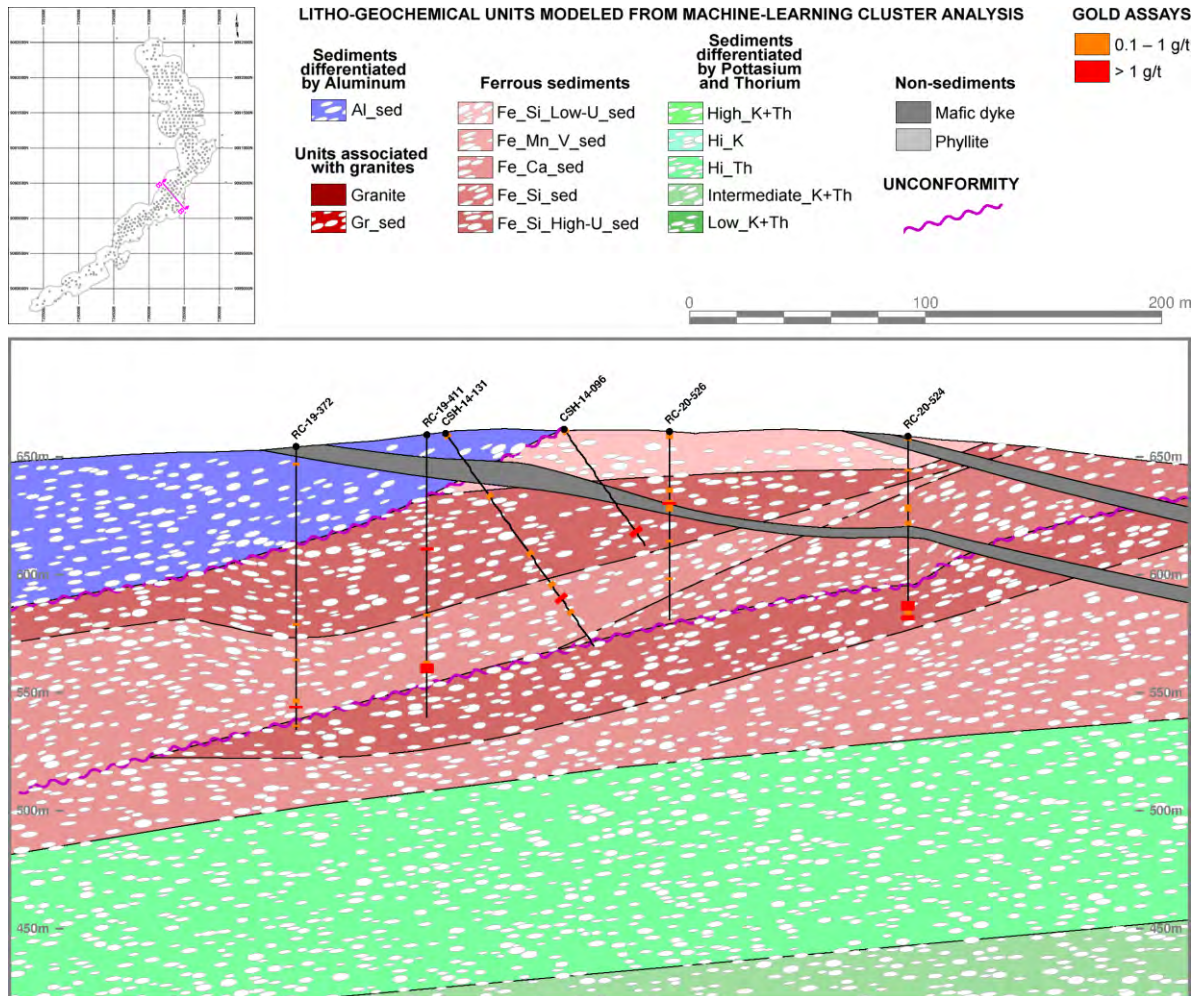

Figure 6-3, Model of litho-geochemical units on cross-section B-B' on the southwest arm of Esperança South, where the mafic dykes cross.

NOTE: except for silica, the specific elements used in the names of the clusters are not major constituents; they occur only in minor and trace quantities, but the machine learning cluster analysis identifies them as important discriminators.

6.4.5.4 Block Model

The resource block model uses 20×20×4m blocks, the horizontal dimension of the blocks is slightly less than half of the 50m drill spacing. The block height is the same as the bench height chosen for the Preliminary Economic Assessment done in 2018.

In each block, the volumetric contribution of the seven domains was calculated directly from the litho-geochemical wireframes and the erosional unconformities. Approximately half of the blocks lie entirely inside a single domain; the other half have a mixture of two or more domains.

All rock in the resource model is assumed to have a dry bulk density of 2.68 t/m³, the average of the density measurements done on drill core in 2018.

For each domain that contributes to a block, Multiple Indicator Kriging (MIK) was used to estimate the gold grade distribution of its selective mining units (SMUs) using nearby samples from the same domain,

Pre-Feasibility Study

with the SMU size based on planned equipment size, bench height, blast hole spacing, and on the experience of the operating mine at Tarkwa, in the same type of paleo-placer gold deposit. A 200×200×25m search ellipsoid was used for the MIK estimates for every domain in every block, aligned with the variogram model for the dominant domain (Figure 6-4)

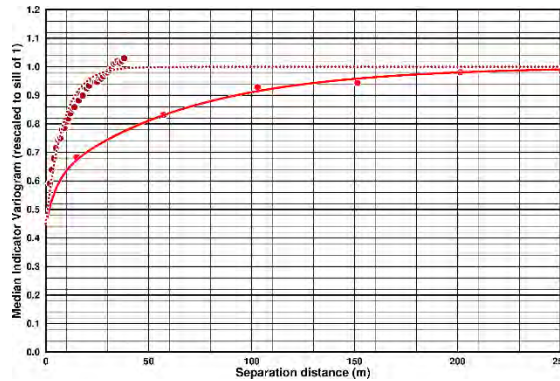

Figure 6-4 Median indicator variography for the ferrous sediments, with the red line showing the omnidirectional variogram in the bedding plane and the dotted dark red line showing the variogram perpendicular to bedding.

6.4.5.5 Classification of Mineral Resources

The mineral resources in Table 6-2 are constrained by open pit shells to meet the requirement that resources have “reasonable prospects for eventual economic extraction”. Within the pit shell material above a cut-off grade of 0.3 g/t was classified as Indicated in blocks for which grade estimation was able to use data from at least two separate drillholes in four octants, and for which the average distance to the nearby data was less than half the variogram range; these criteria are almost always met only in the areas where the drillholes are more closely spaced than 50m. All other blocks with grade estimates were classified as Inferred resources; since the search ellipse was aligned with the variogram ranges, Inferred blocks must have at least one sample within the range of the dominant domain variogram. These block-by-block classification codes were then spatially smoothed to avoid inconsistent classification of isolated blocks.

6.4.6 Summary of historical resource estimate

All the historical estimates that were compliant with National Instrument 43-101 are summarized in Table 6-2.

Pre-Feasibility Study

Table 6-2 Historical Mineral Resources for the Castelo de Sonhos Gold Project.

Year Company	Project Areas Covered	Reporting Cut-off (g/t Au)	Classification	Tonnage (Mt)	Grade (g/t Au)	Metal Content (Moz Au)
2014 RMB Consultoria Mineral	ES + EC	0.4	Indicated	2.8	2	0.2
			Inferred	1.4	2.1	0.1
2017 CSA Global	ES + EC	0.4	Inferred	31	1.3	1.3
2018 GE21 Consultoria Mineral	ES + EC + EE	0.3	Indicated	17.7	1.2	0.7
			Inferred	39.8	1	1.3
2021 TriStar Gold	ES + EC + EE	0.3	Indicated	40.1	1.2	1.5
			Inferred	22.2	1.0	0.7

Pre-Feasibility Study

7 GEOLOGICAL SETTING AND MINERALIZATION

The Castelo de Sonhos gold deposit formed 2.0 to 2.1 billion years ago along the coast of a supercontinent known as ‘Nuna’ (Eglington, 2015). In Figure 7-1 the orange triangles are gold deposits whose ages are known to be 2.0Ga or older, i.e. they all existed, likely along an Andes-like central mountain range, at the time when Castelo de Sonhos was forming. These deposits would have been the natural source for gold grains that were eroded by fast-flowing creeks and rivers with headwaters in the mountains. The gold suspended in flowing water would have been transported down-hill, and would fall out of the flowing water where the water velocity drops: either along the inner edge of bends in the river, on an alluvial plain, or near the mouth of the river, where it opens to the sea.

Castelo de Sonhos was located at the southern edge of the continental plate now called the Amazonian plate (left of Figure 7-1). At approximately the same time as gold was accumulating in the river gravels and pebbles that are now the Castelo de Sonhos deposit, gold was also accumulating elsewhere along the coast of Nuna: on the edge of the continental plate that now forms West Africa, in the deposit that is now being mined at Tarkwa; and on the edge of the plate that is now called the Rio de le Plata plate, in the deposit that is now being mined at Jacobina.

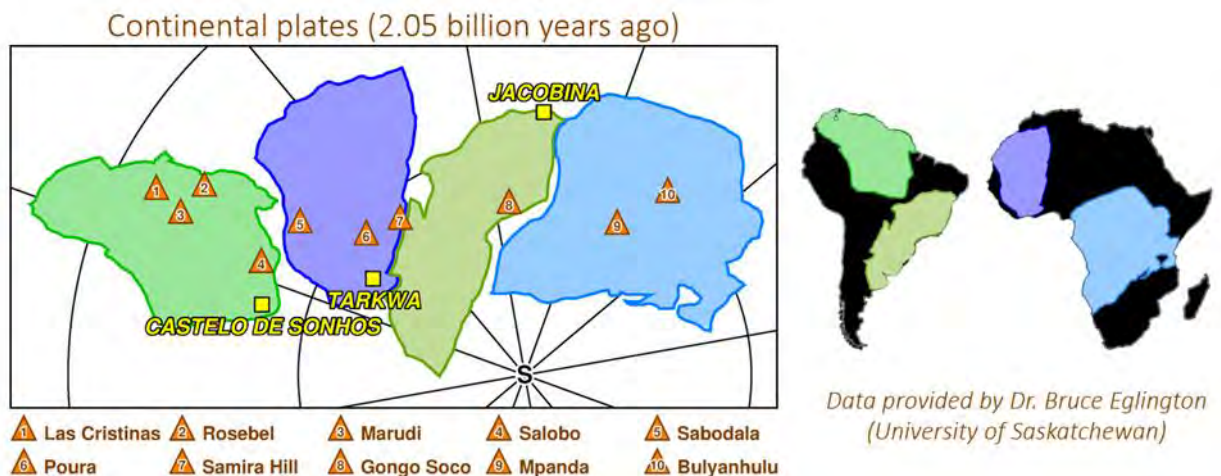

Figure 7-1 Map of the Nuna Super-Continent, with location, at the time, of 10 gold deposits that are at least 2.0 billion years old. The "S" marks the location of the South Pole when Nuna formed; (right) The modern positions of the continental crust that comprised Nuna. (Source: Eglington, 2015).

7.1 Regional Geology

The Castelo dos Sonhos Formation is an isolated package of slightly metamorphosed sandstones and conglomerates which form a roughly circular plateau rising 300m above the surrounding plains near the southern border of Pará State in Brazil. The plateau lies on the Amazonian Craton (Figure 7-2), an ancient continental crust that was first formed three billion years ago and that grew as another continental crust was accreted to it during continental collisions. The Castelo de Sonhos plateau lies at the border between the Tapajós and Iriri-Xingu tectonic domains.

Pre-Feasibility Study

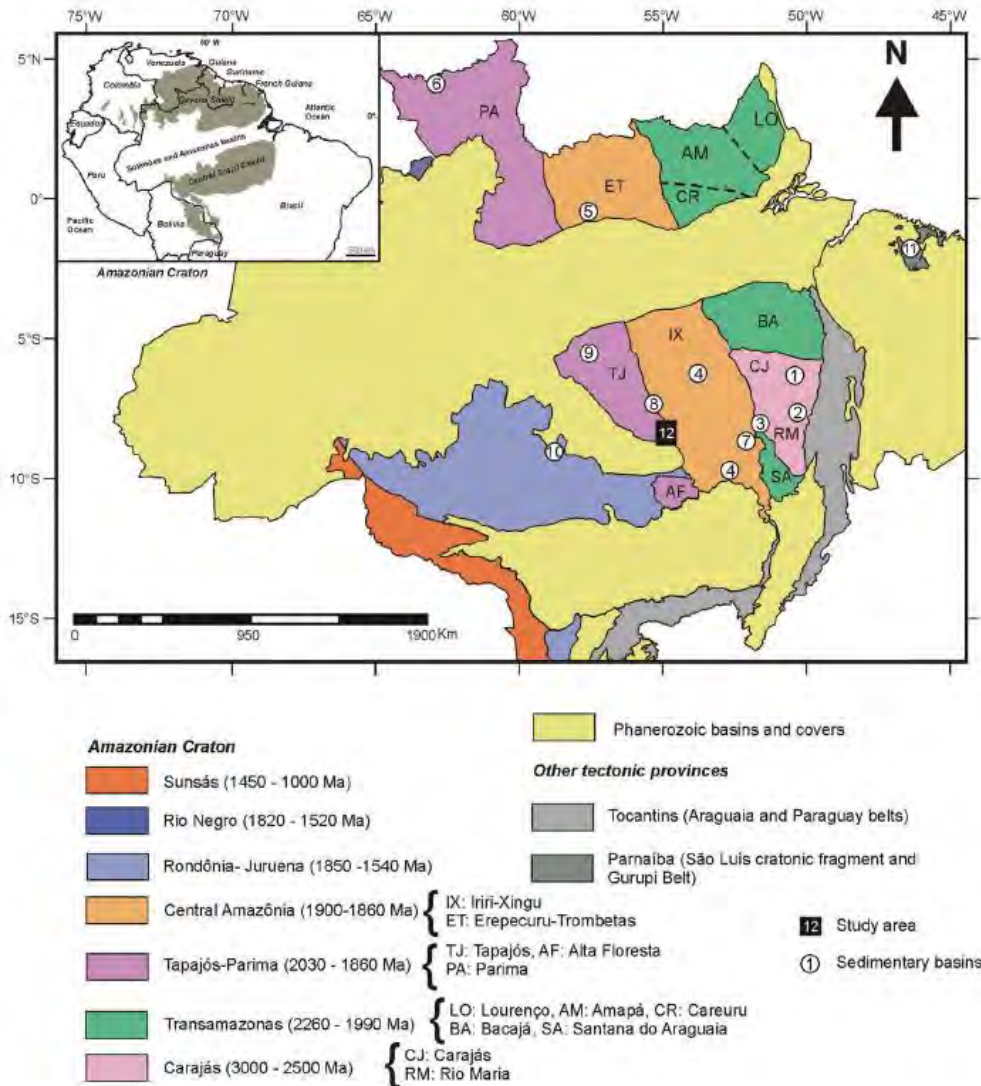

Figure 7-2 Amazonian Craton and its major geochronological domains (Source: Klein et al., 2017).

The Castelo dos Sonhos Formation is a relic of a sedimentary basin that likely formed near the coast, where sediments eroded from higher elevations accumulated in alluvial fans and, occasionally, aeolian dunes. U-Pb isotope dates from detrital zircons indicate that deposition of these sediments occurred 2.01– 2.05 billion years ago in the Paleoproterozoic (Klein et al., 2017), slightly before plate collision that accreted the continental rocks that now form the eastern edge of the Tapajós Domain. The Castelo dos Sonhos conglomerates and sandstones have been gently folded, likely during the continental collisions, and slightly metamorphosed, likely during the intrusions of Maloquinha granites approximately 1.9 billion years ago.

7.2 Stratigraphy

Figure 7-3 shows a schematic column of the broad stratigraphy of the Castelo dos Sonhos Formation. Most of the formation consists of medium to coarse-grained, cross-bedded sandstones that are described locally as metamorphosed arenites. At places within the formation, the size of the particles

Pre-Feasibility Study

increases, and the formation becomes a proper conglomerate. In the stratigraphically vertical direction, fluctuations between sandstones and conglomerates were influenced by the rate of sediment accumulation, how close (or far) they were from the source where they eroded, and how mature they were (i.e. their size, roundedness and sorting).

The gradual nature of these changes gives rise to a continuous spectrum, from sandstones (mA) to conglomeratic arenites (mAC) to conglomerates (mC). In the conglomerate, pebbles range in size from granules (~2mm) to large boulders (~1m). Where the pebbles touch each other, the conglomerate is described as clast-supported (mC1); where they do not touch each other, it is described as matrix-supported (mC2). Where the entire conglomerate consists of small granules and has the appearance of a gritstone, it is described as a micro-conglomerate (mC3).

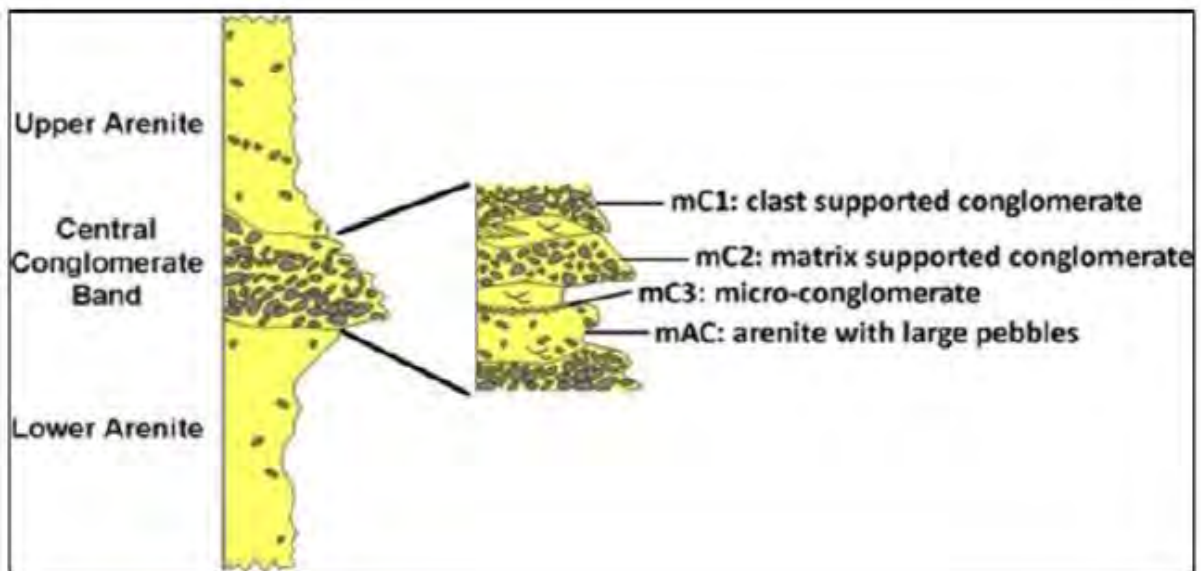

Figure 7-3 Schematic stratigraphy of the Castelo dos Sonhos Formation.

Most of the gold mineralization in the Castelo dos Sonhos Formation lies in a central band where the various conglomerate lithologies dominate. At the base and top of this band, the conglomerates are interlayered with arenites, which become more frequent as one moves away from the conglomeratic band, either downward into the older rocks (the lower arenite) or upward into the younger rocks (the upper arenite).

The central conglomeratic band is 250–300m thick; the upper and lower arenites are more than 500m thick. At least one additional untested conglomeratic band, in the order of tens of meters thick, is known to occur in the upper arenite.

Figure 7-4 shows a schematic column of the stratigraphy within the main conglomeratic band, along with the conceptual model that summarizes the current understanding of the original depositional environment: a Gilbert fan-delta in which deposition occurs sub-aerially near the head and sub-marine near the toe, with sea-level changes affecting the location of the shoreline (Kosters and Steel, 1984). The conglomerate band can be broadly divided into three units, with the cobbles being smaller and less frequent in the upper and lower units. The gradual progression in the stratigraphically vertical direction,

Pre-Feasibility Study

from finer-grained sediments to coarser is believed to reflect the sequence typically seen in alluvial and deltaic fans that build outwards as they also build upwards.

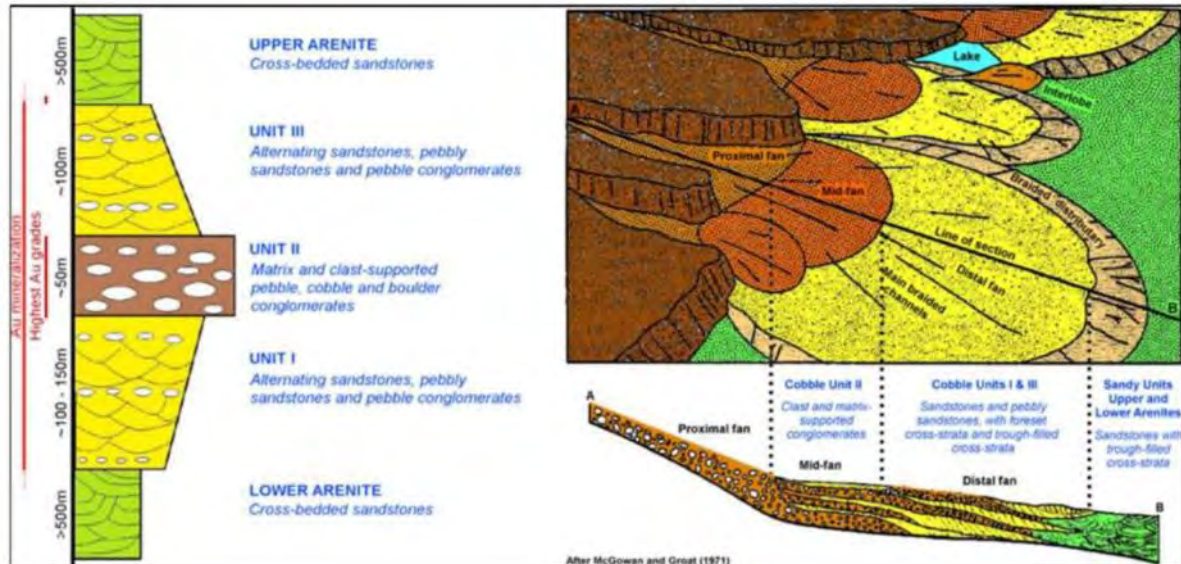

Figure 7-4 Schematic stratigraphy of the main units within the central conglomeratic band of Castelo dos Sonhos Formation, and conceptual model of the depositional environment. (Source: Modified by Karpeta, 2016, after McGowan and Groat, 1971)

The vast majority of clasts in the conglomerate are from quartz veins; minor amounts of the pebbles consist of banded iron formation, quartzite, tourmalinite and, less frequently, metavolcanics. Significantly, no clasts of granite or andesite have ever been seen, indicating that these rocks, which lie beneath the Castelo dos Sonhos Formation, are due to intrusions that post-date the sediments. A few of the pebbles and cobbles are composed of the Castelo dos Sonhos Formation itself, indicating that successive lobes of the alluvial fan have sometimes scavenged and reworked older lobes beneath them.

Structural deformation of the sedimentary rocks (discussed below) removes any possibility of establishing an absolute sense of the original paleo-current directions. But trough cross-bedding in the sandstones and pebble imbrication in the conglomerates both establish that the paleo-current was from the northeast to the southwest in today's orientation of the plateau (Karpeta, 2016; Lipson, 2016).

7.3 Metamorphism and Structural Deformation

As the continental crust of the Tapajós Domain accreted from the west, the foreland basin closed, and the sedimentary rocks of the Castelo dos Sonhos Formation were intruded by granites and andesite between 1.9 and 2.0 billion years ago. The sedimentary rocks were metamorphosed by heat from these intrusive events, and by hydrothermal fluids driven upward from the intrusions. The metamorphism was low grade and left the original sedimentary fabric apparent (Queiroz, 2015).

The outcrop of the conglomerate band approximately follows the rim of the plateau, its arcuate shape being the result of folding and tilting of the alluvial fan from its original flat-lying orientation (Figure 7-5);

Pre-Feasibility Study

the axial plane of the fold runs northeast to southwest through the nose at the north end of Esperança Center.

The cross-section in Figure 7-5 shows an interpretation of the shape of the folded conglomerate band. Within the areas where drilling has occurred, and where most of the garimpos are located, the hinge-line of the fold appears to plunge to the southwest, but the fold may, in fact, close on the less-studied west side of the plateau, forming a bowl-shaped structure whose western limb is slightly overturned (Lipson, 2016).

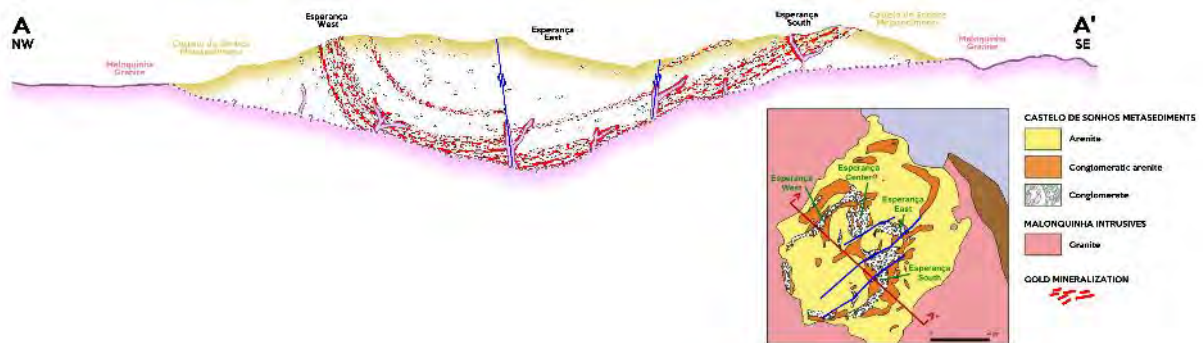

Figure 7-5 Map and schematic cross-section of the bedrock geology of the Castelo de Sonhos plateau.

In Esperança South, bedding dips 25–35° to the northwest. On the north-south limb of Esperança South, in Esperança East and Esperança Center, the dip is slightly shallower (20–30°) and to the west. The bedding dip begins to steepen at the nose of the fold at the north end of Esperança Center, reaching 50–60° degrees at the north end of Esperança West, where it dips to the southeast. Bedding becomes nearly vertical as one moves to the south along Esperança West and becomes slightly overturned in outcrops on the far western edge of the plateau.

Two major faults offset the conglomerate band on the eastern side of the plateau. Although these are interpreted as strike-slip faults in Figure 7-5, regional stress considerations make it more likely that these are principally dip-slip faults, with the Esperança East block being down-dropped and the apparent eastward displacement being a consequence of the downward movement of a band that dips to the southwest.

Geological characteristics that reflect stress and strain, such as shearing in mylonites and pebble elongation in conglomerates, are all approximately aligned in the same direction, sub-parallel to the faults that offset Esperança East.

7.4 Hydrothermal Alteration

Hydrothermal alteration events affect much of the mineralized conglomerate band. The most widespread of these are silicic and hematitic alteration, both of which can, in places, be intense. Other alteration minerals that are less widespread and generally less intense include sericite, muscovite, fuchsite and epidote.

Pre-Feasibility Study

Much of the silicic alteration was likely drawn from quartz in the sediments that were precipitated a short distance from where it was dissolved. Much of the iron must have been sourced from the underlying intrusions, travelling upward along fractures in fluids, occasionally forming visible dikes that penetrated the sediments. The lack of chilled margins on the dikes indicates that the temperatures were low when they were emplaced.

As granitic dikes have been observed in the conglomeratic band, it is assumed that the underlying granitic intrusion probably removed the deeper parts of the bowl-shaped conglomeratic band; but this has not been directly observed in any drillholes, most of which are relatively shallow. The deepest hole, drilled in the center of the plateau, reached a depth of 500m, and remained entirely in the upper arenite without ever reaching either the top of the conglomerate band or the intrusive granite.

7.5 Mineralization

Gold occurs as free grains and flakes of various sizes, from sub-visible (less than 100 microns) to highly visible. In the near-surface workings dug by local artisanal miners, supergene enrichment creates nuggets that can reach a few centimeters in size.

The two predominant styles of mineralization are:

- **Paleo-placer:** Free grains of gold that were likely deposited along with the quartz-rich sediments. In core these can be seen in the matrix of the conglomerate, sometimes in heavy mineral bands.
- **Remobilized:** Gold associated with alteration, usually hematitic alteration. Free grains of gold have been observed in hematite-filled fractures, and as thin films plated onto fracture surfaces.

As shown on the left side of Figure 7-4, gold mineralization occurs throughout the conglomeratic band. Although there are many barren samples within the conglomerate, there are gold grades above 0.5g/t in almost every drillhole that penetrates more than half of the stratigraphic thickness of the central conglomeratic band. Gold grades tend to be higher in the central cobble unit, often reaching several grams per tonne. The lowest grade encountered in drilling to date is below the detection limit; the highest grade encountered in drilling to date is a 160g/t assay over a 1m interval. The existence of gold in heavy mineral bands, and its tendency to be more frequent in the proximal rocks are consistent with the view that most of the gold in the conglomerate band was deposited along with the sediments.

Where gold mineralization extends into the upper and lower arenites, such as the interval of 5 – 10g/t mineralization seen at the base of the upper arenite in several Esperança South drillholes, this is understood to be the result of remobilization caused by hydrothermal fluids. This remobilized gold in the arenites, along with direct observations of gold in direct association with hematite-filled fractures in the conglomerates, confirms that some of the gold within the conglomerate band must also be remobilized. The low temperatures of dike emplacement, the low grade of metamorphism, the difficulty of keeping gold in solution, and the proximity of the remobilized gold in the arenites to the conglomerate band all support the view that remobilized gold did not travel far from where it was originally deposited as paleo-placer gold. There is currently no evidence that any of the remobilized gold has migrated more than a few tens of meters.

Pre-Feasibility Study

The strike length of the mineralized conglomerate is approximately 16 km; samples from outcrops and workings along the entire length of this band return both barren samples and well-mineralized samples. The true width of the central conglomerate band is 250-300m. At the surface, the apparent width is close to the true width in Esperança West, where the dip is vertical and is approximately three times the true width in Esperança Center, where the dip can be as low as 20°.

The true depth of mineralization is unknown since the deepest parts of the conglomerate have never been encountered in drilling but are known to be at least 500m from the surface in the center of the plateau. In drillholes, well-mineralized samples (above 4g/t) have been encountered at depths of 300m. The current mineral resource estimate spans the conglomerate band from hanging wall to footwall but is restricted in its strike length by the availability of drilling and by the decision to report resources to a depth of only 150m. Some of the blocks on the edge of the current resource model are well mineralized, leaving the model open in the strike direction and down dip.

The garimpeiros followed high-grade reefs very closely, with their hand-dug trenches stepping over wherever faults disrupt the continuity of the reefs they were mining. The hand-dug garimpos show that the continuity of mineralization is very strong at the surface and to depths of several tens of meters where the garimpeiros dug tunnels to follow gold reefs at the base of their trenches. Between offsetting faults, many of the individual garimpos are several hundred meters in length.

The longest of the garimpos extends unbroken for more than 500m in length. With the surficial weathered layer being very thin (1 to 2 meters), almost all the garimpos, including all the longest ones, are continuous in fresh unweathered rock, so it is assumed that the 100-500m continuity of high-grade zones seen in the garimpos is typical of the continuity of mineralization in the near-surface region covered by the open-pit resource block models.

7.6 Mineralization Thicknesses and Orientation

7.6.1 Esperança South

The mineralization in Esperança South is hosted in a series of stacked metaconglomerate beds striking north-south or northeast-southwest and dipping west, or northwest, at 30° to 35°, with thicknesses of individual mineralized reefs ranging from 2m to 20m. The mineralized reefs in Esperança South are thinner than in Esperança Center but have higher gold grades. This is consistent with the interpretation that the proximal (land) side of the Gilbert fan-delta system lay in what is now Esperança Center and the distal (sea) side lay in what is now Esperança South. Continuous winnowing of the Esperança South sediments in a near-shore sub-marine environment would have caused free gold grains to accumulate in narrow intervals, creating well-mineralized bands that are thinner but also higher in grade, separated by thick intervals with little gold. At the head of the fan, in Esperança Center, where there would have been little reworking and winnowing of the sediments, mineralization is more pervasive but also lower in grade.

Pre-Feasibility Study**7.6.2 Esperança Center**

The mineralization is hosted in a series of beds, striking north-south and dipping 20° to 30° west. Thicknesses of individual mineralized reefs range from 1m to 20m. Although the highest grades in Esperança South are higher than in Esperança Center, it is Esperança Center that has the higher average grade because it has far fewer very low-grade intervals. With more of the grade distribution lying close to an average of 0.2g/t, the thickness of mineralized horizons in Esperança Center increases as the cut-off used to define a significant interval is lowered. At cut-offs near 0.2g/t, Esperança Center has many thick intervals, some exceeding 50m.

7.6.3 Esperança East

Esperança East is more structurally complex than Esperança Center and Esperança South, with bedding directions often changing quickly between the available outcrops. Generally, the mineralization dips to the west, consistent with the view that the Esperança East block is the bridge between Esperança Center and Esperança South.

Parts of Esperança East more closely resemble Esperança Center, with long runs of mineralization near 0.2g/t; other parts more closely resemble Esperança South, with grades occasionally exceeding 10g/t over short intervals.

7.6.4 True Thickness

Almost all diamond holes were drilled to intercept the mineralized beds at right angles, or as close as practically possible, in Esperança South, Center and East. As a result, the core axis angle of bedding is often very high (70–90°), making the apparent thickness of most intervals from diamond drillholes very close to true thicknesses. In RC holes, which were drilled vertically, the apparent thickness of an interval observed in the hole is about 15% longer than the true thickness, due to a bedding dip that averages 25° to 35°.

Pre-Feasibility Study

8 DEPOSIT TYPE

Castelo de Sonhos displays all the characteristics of the paleo-placer deposit type when compared with the most important mined deposits of this class elsewhere in the world (Table 8-1). This is particularly true when compared with Tarkwa and Jacobina, deposits that are of similar Paleoproterozoic age to CDS. The presence of hematite in the conglomerate matrix is another important similarity with these paleo-placer deposits. The variation in the composition of the conglomerates, from pebbles of the same type (oligomictic) to pebbles of several types (polymictic) is very similar to Tarkwa, as is the degree of deformation. The style of cross-bedding in the surrounding arenites is common to all four (Table 8-1).

Although the deposits in Table 8-1 are all generally regarded as paleo-placers, they all also show clear evidence for gold remobilization, which causes them to often be referred to as “modified paleo-placers” (Frimmel, 2014; 2005). It is most likely that all gold originated in a paleo-placer setting since there is no gold associated with the rare quartz veins which cut the deposit. This style of mineralization would be expected were there a component of superimposed hydrothermal gold input as is found at the Damang deposit developed in the Tarkwa siliciclastic sequence in Ghana (White et al., 2010).

Table 8-1 Geological characteristics of Castelo de Sonhos and other modified paleo-placers.

	Witwatersrand	Tarkwa	Jacobina	Castelo de Sonhos
Age	2.6 to 2.8Ga	2.1Ga	2Ga	2 to 2.1Ga
Conglomerate hosted	Yes	Yes	Yes	Yes
Silicification	Yes	Yes	Yes	Yes
Fuchsite in quartzites	Yes	Yes	Yes	Yes
Carbon	Yes	No	Yes	No
Hematite	No	Yes	Yes	Yes
Magnetite	No	Yes	No	Yes
Pyrite	Yes	No	Yes	No
Uranium	Yes	No	Yes	Anomalous in footwall
Cross-bedded quartzites	Yes	Yes	Yes	Yes
Mineralization thickness	0.1 to 3m	Up to 8m	1 to 10m	1 to 20m

Pre-Feasibility Study

9 EXPLORATION

9.1 Exploration Program

There have been two major periods of exploration at Castelo de Sonhos: from 1995 to 1996 when Barrick held the mineral claims, and from 2011 to the present, under TriStar. During both periods, exploration consisted of drilling (summarized in Section 10 – Drilling), airborne geophysics, soil sampling, surface mapping and outcrop sampling, as summarized in Table 9-1.

Table 9-1 Summary of exploration work completed on the Castelo de Sonhos property.

Year	Company	Task carried out by:	Work completed	
1995 to 1996	Barrick	Barrick Staff	Soil/rock sampling	
			Stream sediment sampling	
		SETA	Trench sampling	
			Core drilling	
			Barrick Staff	Tracks opened for geochemical soil sampling
			Satplan Ltda	Topography
2011 to present	TriStar	Geomag/Aerodat Inc	Airborne geophysics (mag/gamma) 200m spacing	
		TriStar Staff	Surface mapping	
			Geochemical sampling	
		Fugro - Lasa Prospecções S.A	Soil/rock sampling program	
		Layne do Brasil	Airborne geophysics (mag/gamma) 200m spacing	
		TriStar Staff	Core drilling	
		Geosedna/GeoLogica/Geosol/Servitec Foraco	Exploration target range	
			RC drilling	
		DGI Geoscience/AFC Geofísica	OTV/Downhole petrophysics	
		Rael Lipson/Paul Karpeta	Detailed sedimentological mapping	
		Satplan Ltda	Topography	
GeoSolid	LIDAR survey and orthophotos			
GoldSpot Discoveries	Multi-element chemistry clustering using A.I and Machine Learning			

9.1.1 Barrick (1995 to 1996)

The exploration campaign undertaken by Barrick proved helpful to TriStar for planning and executing future exploration programs. The available data from Barrick’s geochemical assays, geophysical maps and geological mapping compared well with TriStar’s versions of similar data and were deemed reliable and trustworthy. However, many of the Barrick drillhole collars were excavated over time by garimpeiros who used the strategic locations of the drillholes as indicators for mineralization. Two of these collars can still be located in the field today.

In addition to the drilling, airborne geophysics, soil sampling, surface mapping and outcrop sampling, the Barrick campaigns also included the collection and analysis of almost 700 stream sediment samples.

Pre-Feasibility Study

9.1.2 TriStar (2011 to Present)

In 2011, TriStar constructed the field camp, rebuilt the airstrip and rebuilt the access roads. Since 2011, TriStar has completed an airborne geophysical survey, soil sampling, geological mapping and rock chip sampling programs. In addition, various complementary studies on structure, lineament analysis, satellite imagery and petrology were undertaken.

With the decision to start using reverse-circulation (RC) drilling in 2017, TriStar also undertook petrophysical logging and optical televiewer (OTV) imaging of drillholes so that the OTV images could support the logging of geological and structural information that is often difficult in RC holes.

Recently, TriStar has analyzed multi-element chemistry clusters that can be integrated with many other sources of information to identify mappable stratigraphic units. In 2020, TriStar commissioned a LIDAR survey of the plateau that included a complete set of high-resolution aerial photographs.

9.2 Geochemical Soil Sampling

The soil sampling programs covered most of the claims deemed to have good exploration potential and were completed on a systematic 100 m x 50 m grid ultimately covering the whole conglomerate outcrop. In areas where the terrain was adjudged to be less likely to contain mineralization, the spacing between samples was increased.

In 2020, after discussions with GoldSpot Discoveries and Rael Lipson, soil sampling locations were suggested in new areas deemed to have the potential for mineralization. The sites centered around granite outcrops where remobilized gold was targeted.

Over the entire lifespan of the project, a total of 11,984 soil samples have been sent to various labs for gold analysis.

9.3 Mapping

Early mapping of the area was completed by TriStar geologists and revealed a band of metaconglomerates outcropping on the Project concessions for 16km in a horseshoe shape, open to the west. More recent mapping has revealed that the “horseshoe” closes on the west and that the band of metamorphosed conglomerates forms a roughly circular structure that rims the plateau (Figure 9-1). The shape of the conglomerate band is due to the folding and faulting of the original flat-lying fan of sediments.

Pre-Feasibility Study

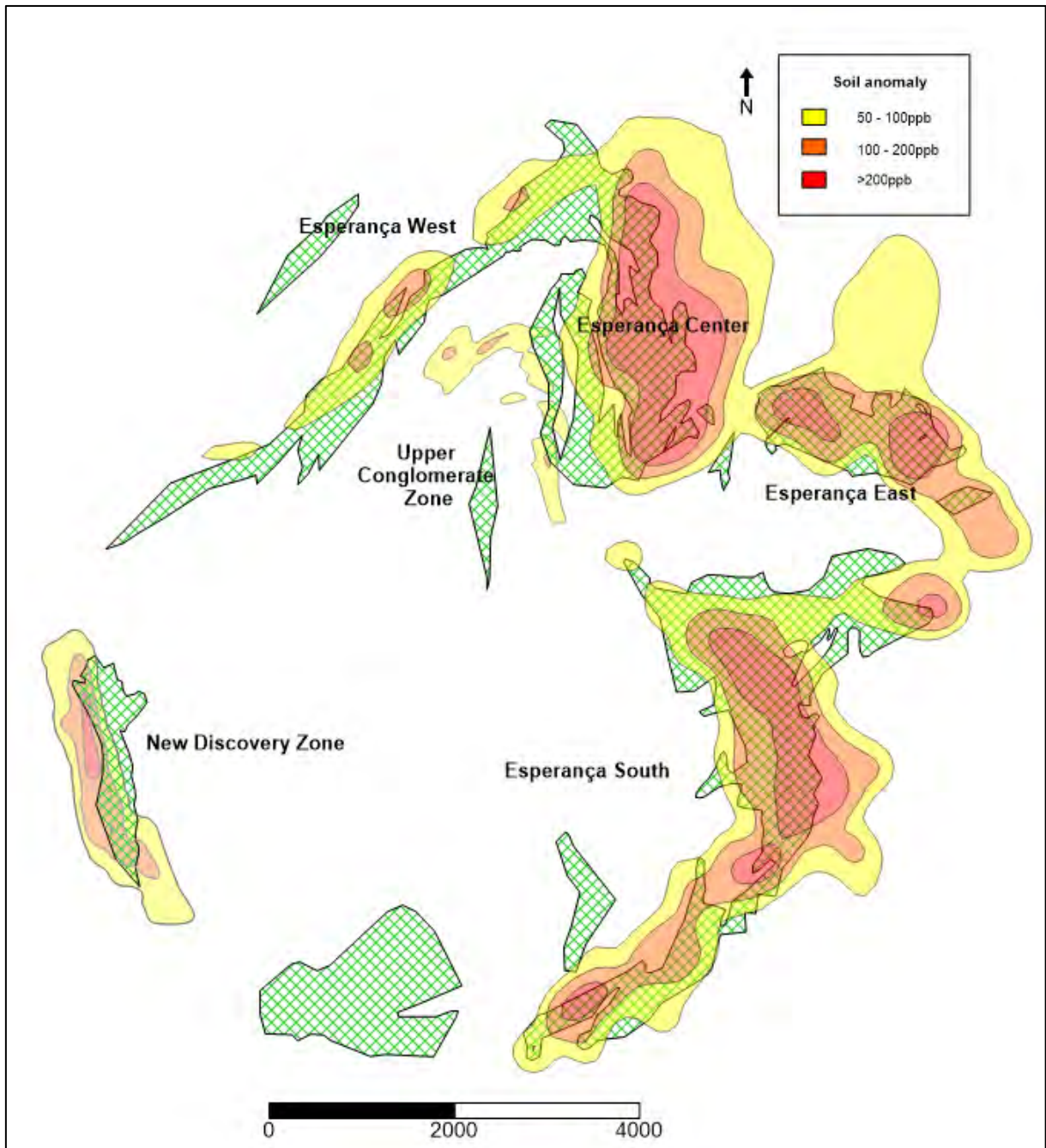

Figure 9-1 Soil sample anomalies (isolines) and mapped metaconglomerate bands (green hatch) at Castelo de Sonhos.

Surface reconnaissance has also confirmed the existence of a thinner conglomerate band that sits in the upper arenite, several hundred meters above the main band.

Since 2016, Rael Lipson and Paul Karpeta were contracted by TriStar to assist in developing an understanding of the evolution of the Castelo de Sonhos deposit and the factors that control and influence gold mineralization on the plateau.

Pre-Feasibility Study

Both of these geologists have extensive experience on paleo-placer deposits, including the strongly analogous Tarkwa deposit in Ghana. They identified detailed mapping of sedimentary structures as one of the cornerstones of a coherent and consistent geological model for Castelo de Sonhos, and each spent several weeks in the field, acquiring data across the plateau on paleocurrent directions (from trough cross-bedding and pebble imbrications), pebble elongations, foliation and bedding orientations and spatial variation in statistics of pebble sizes. Their work has also led to improvements in core logging procedures that capture information on characteristics of pebble geometry and sedimentary features that have proven useful for resource modelling at other paleo-placer deposits.

9.4 Geophysical Surveys

TriStar contracted Fugro-Lasa S.A. (of Rio de Janeiro) to complete an airborne magnetic and radiometric geophysical survey to cover all areas of the Castelo de Sonhos Gold Project site. The survey covered over 7,000km of flight lines at an altitude of 100m.

The data obtained allowed for the generation of nine different maps: residual magnetic field, analytical signal and residual magnetic field, the first vertical derivative of the residual magnetic field concentrations of radiometric channels potassium, uranium and thorium, total count, ternary radiometric channels and a digital terrain model.

9.5 Petrophysical Downhole Surveying and Optical Televiewer (OTV)

In 2017, TriStar completed a borehole petrophysics and OTV program on a selection of the diamond core drillholes (Figure 9-2 and Figure 9-3) and RC holes. The second campaign of OTV logging was conducted in 2019-2020.

During the 2017 petrophysical and OTV logging campaign, AFC Geofisica, a Brazilian company based in Porto Alegre, was contracted to measure natural gamma, resistivity, temperature, fluid conductivity and sonic velocity. DGI Geoscience, a Toronto-based company, imaged the drillholes using an optical televiewer. They also measured the magnetic susceptibility and downhole orientations of the drillholes.

In 2019-2020, AFC and DGI worked together, focusing on acquiring OTV images in the Esperança South area.

The holes were selected based on their availability and strategic locations along strike and intersections of zones of good gold mineralization. Several holes were not accessible due to blockages.

Pre-Feasibility Study

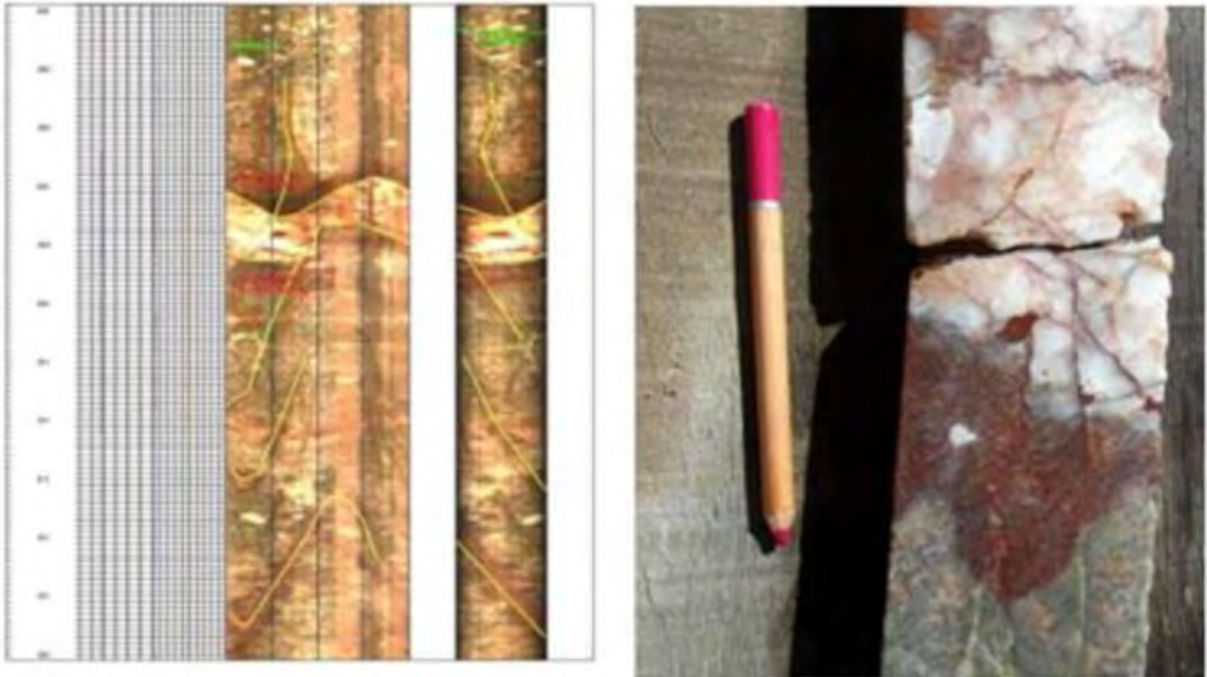

Figure 9-2 OTV image of a diamond hole compared with actual core from the same interval.

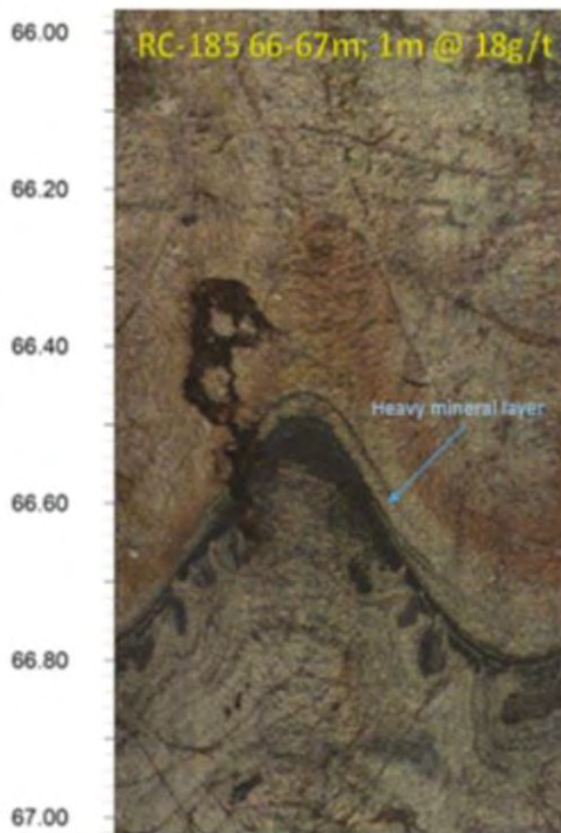

Figure 9-3 Example of OTV image in an RC drillhole section.

Pre-Feasibility Study

9.6 Multi-Element Chemistry

In 2012, TriStar sent three core holes for ICP analysis. The results were sent to GoldSpot Discoveries to attempt to reveal any chemically similar horizons that appeared to be correlatable. GoldSpot was able to show that cluster analysis worked well for those three holes and because of this, TriStar sent 13 more holes, all in close proximity to each other, for additional ICP analysis.

Figure 9-4 shows that the results were encouraging. It reveals that the clusters identified by machine learning algorithms form thick bands of similar chemistry within a hole and are correlatable from hole to hole.

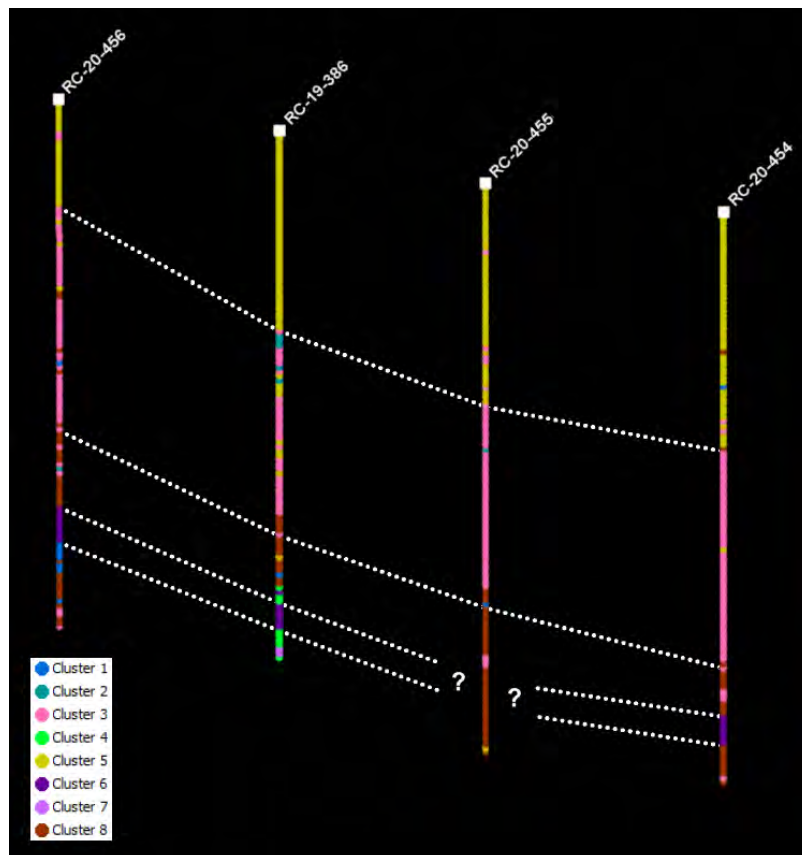

Figure 9-4 Example of clusters developed by machine learning from 4A-ICP multi-element chemistry, and correlatable from hole to hole, with the interpretation of marker horizons.

Following the successful demonstration of the consistency and correlatability of machine-learning clusters, TriStar has the lab do 4A-ICP analysis on every other sample as part of its regular protocol.

Much of the multi-element chemistry fingerprint of a sedimentary sequence is due to the details of the bedrock being eroded by creeks, streams, and rivers at higher elevations in the hinterland. Cluster analysis aims to identify these geological fingerprints that were deposited at the same time, along with changes in erosional patterns and group them in the vertical profile.

Pre-Feasibility Study

GoldSpot was able to integrate the geochemical clusters with geophysics, topography, and air photos from the LIDAR survey as well as TriStar's geological mapping of the plateau to create a 2D map of the major litho-geochemical units shown in Figure 9-5.

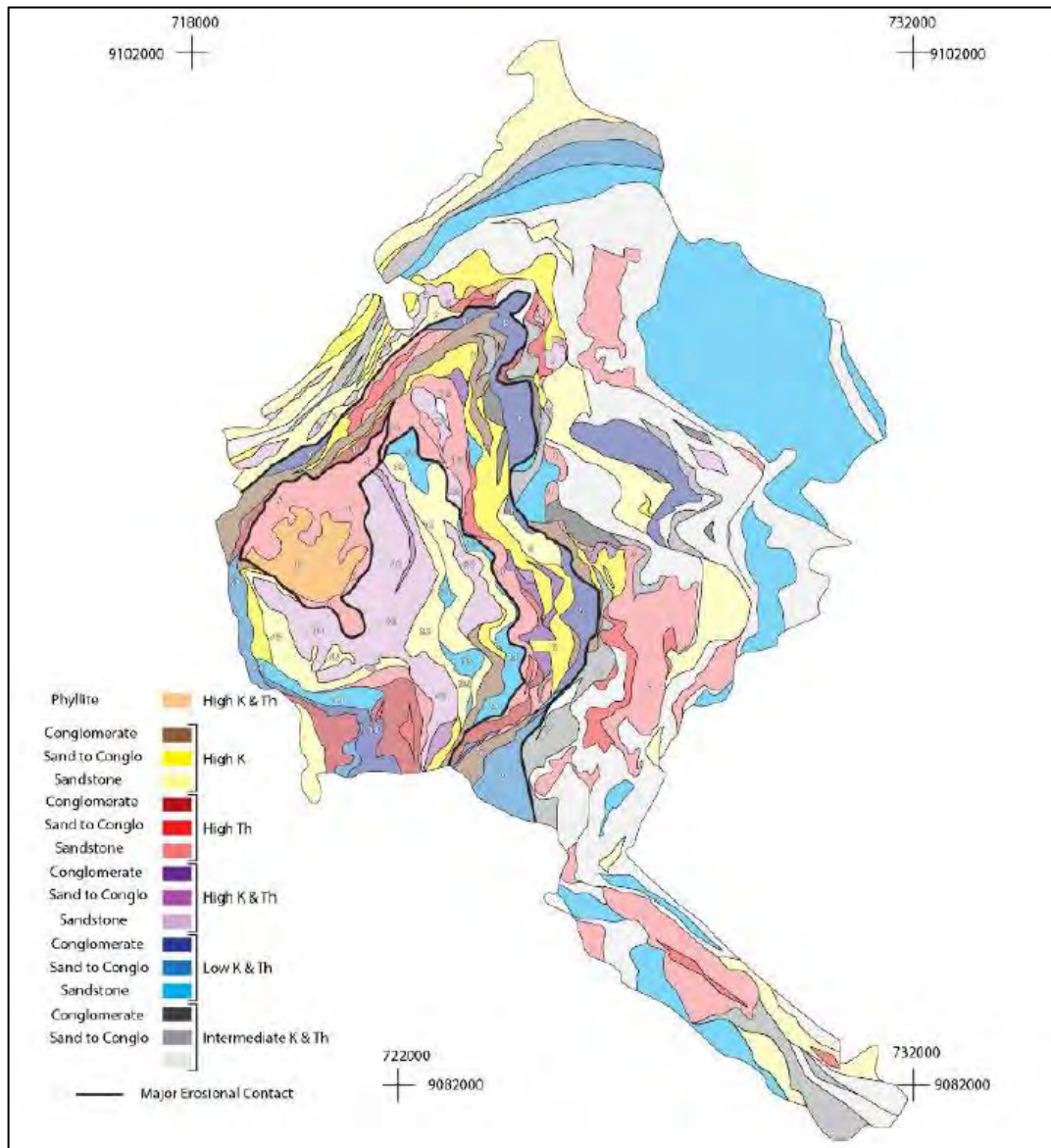

Figure 9-5 Preliminary interpretation of surficial geology using multielement geochemical clusters and information from 2D surface data sets such as airborne geophysics.

Using the integrated 2D map, GoldSpot undertook 3D modelling that honours the information at depth from cluster analysis in drillholes, that honours surface information and that incorporates surface reconnaissance measurements of bedding strikes and dips to create a coherent and consistent three-dimensional interpretation of the major litho-geochemical units and the erosional surfaces across the entire Castelo de Sonhos plateau.

Figure 9-6 and Figure 9-7 show examples of the interpreted litho-geochemical units and erosional surfaces on two cross-sections. 15 units in total were interpreted and rendered as wireframed solids.

Pre-Feasibility Study

Some of these are sedimentary units that run sub-parallel to the bowl-shaped stratigraphy of the plateau's meta-sediments, identified by the predominating elements that allow the clusters to be differentiated from each other. Others do not run parallel to the general bedding direction; instead, they are non-sedimentary rocks that cut across the stratigraphy.

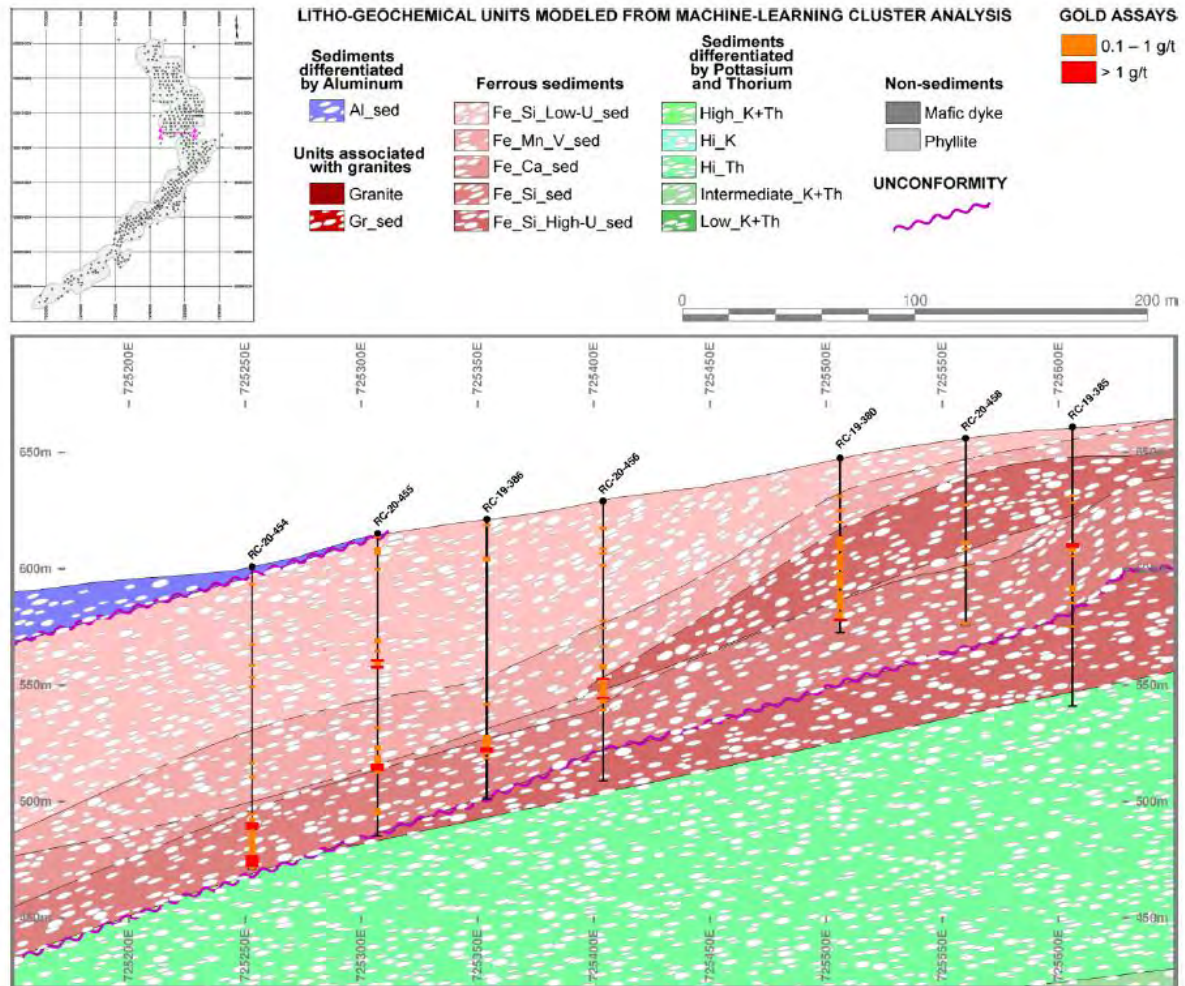

Figure 9-6 Model of litho-geochemical units on cross-section A-A' on the north arm of Esperança South.

Pre-Feasibility Study

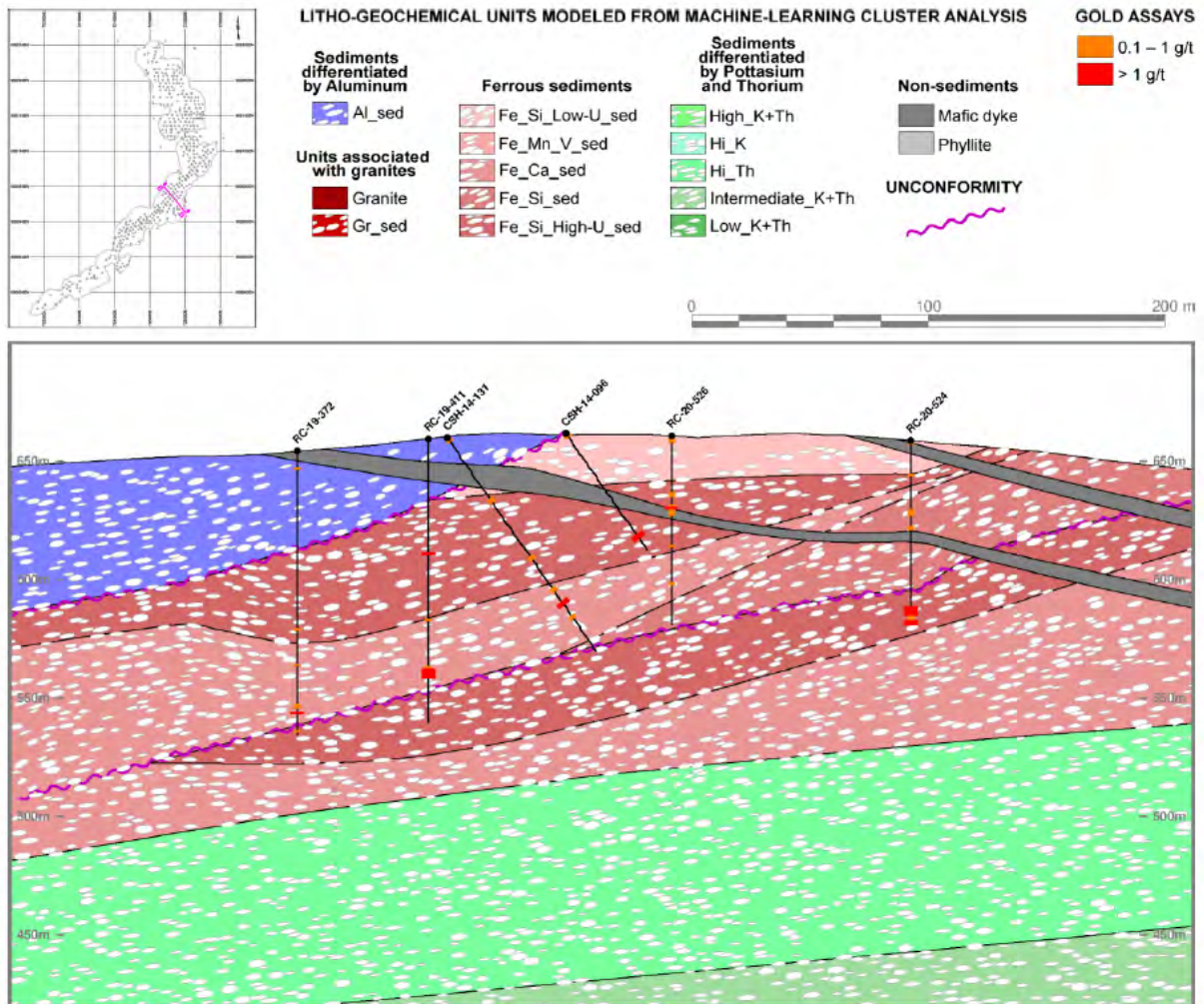

Figure 9-7 Model of litho-geochemical units on cross-section B-B' on the southwest arm of Esperança South, where the mafic dykes cross.

The three that cut across stratigraphy are a granitic cluster that corresponds to dykes from the large granitic intrusion that lies beneath the plateau; a cluster that correspond to two east-west mafic dykes with shallow dips (~20°) to the south; and a phyllite that only influences the Esperança Center modelling area.

As indicated schematically by the pebble texture used in Figure 9-6 and Figure 9-7, the bedding is interpreted to run parallel to the top and bottom of each of the sedimentary units, except where the top is an erosional surface or is the current topography. Erosional surfaces cut across the stratigraphy of the underlying layer, and form the base that the stratigraphy of the overlying layer will initially run parallel to.

9.7 LIDAR Topography and Aerial Imagery

In 2020, TriStar contracted Geosolid Geoprocessamento e Mapeamento to survey a large area covering the entire project region including the proposed location of tailings and the road to the village. Detailed elevation surfaces were provided in 1,240 500 x 500m tiles, each tile containing about half a million XYZ points. Relative adjustments were performed using surveyed ground control points located around the

Pre-Feasibility Study

plateau. Geosolid also provided high-resolution orthophotos. The LIDAR surfaces and orthophotos were used to confirm and increase confidence in the surficial geological interpretations.

The area covered by the LIDAR topography is shown in Figure 9-8



Figure 9-8 Areal extent of LIDAR and orthophoto provided by Geosolid. Red outline shows current concession boundaries.

9.8 Density

The density data base is available in 28 drill core samples of the conglomeratic horizon that had an average dry bulk density of 2.68 t/m³. This is very similar to the densities used for resource estimates at Tarkwa and Jacobina, the two closest analogues of CDS, and slightly lower than values in technical papers for the density of strongly silicified and hematized quartzites.

Pre-Feasibility Study

10 DRILLING

Seven drilling campaigns have been carried out at Castelo de Sonhos Project by TriStar (Figure 10-1). The campaigns in 2011, 2012, 2014 and 2016 were all diamond drilling; the 2017 campaign consisted entirely of RC drilling, and the 2018 to 2021 campaigns consisted of a combination of RC and diamond drilling. In Castelo de Sonhos Project, 211 diamond holes (25,020m) and 400 RC (42,024m) holes have been drilled.

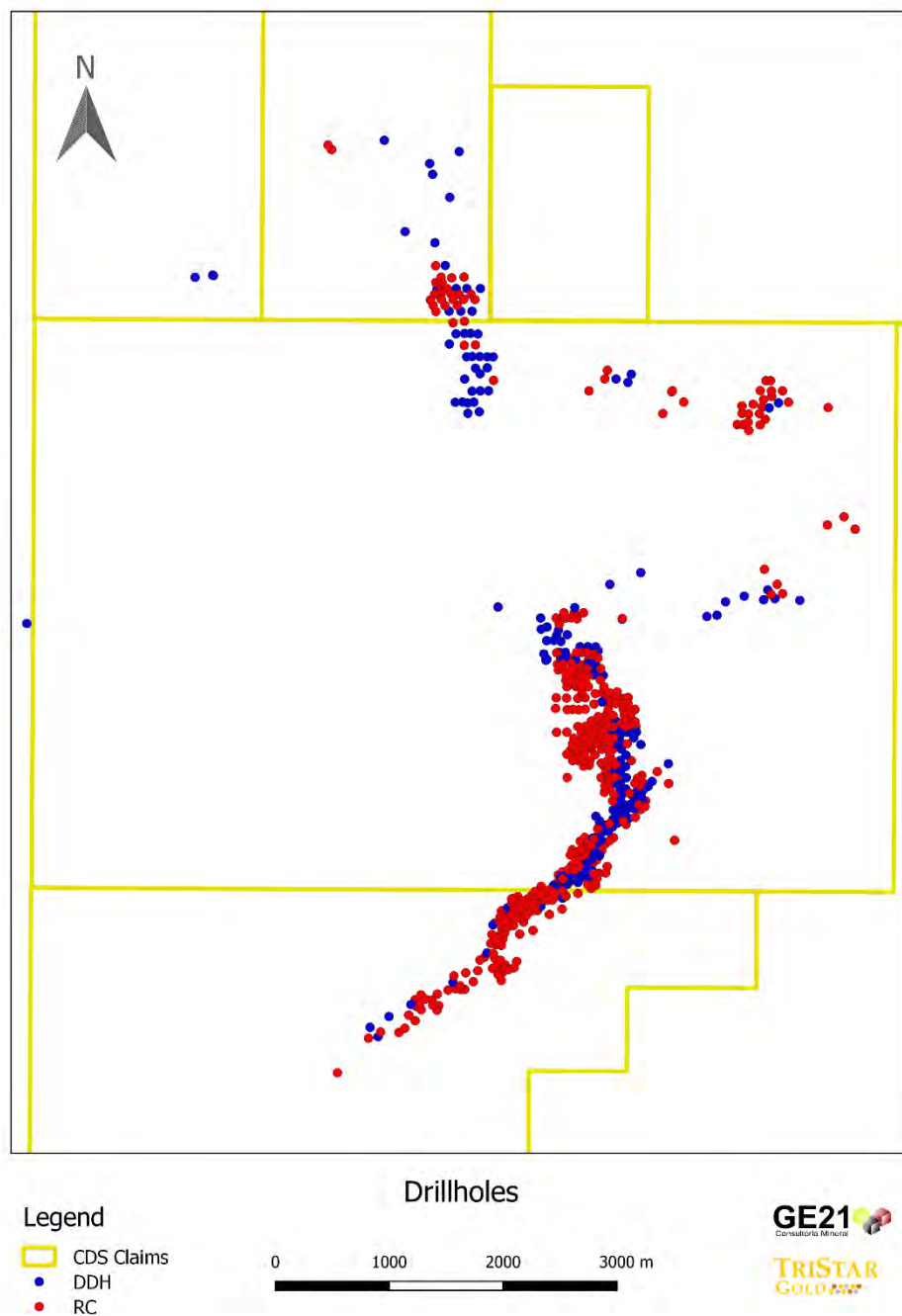

Figure 10-1 Diamond (blue) and RC (red) drillholes.

Pre-Feasibility Study**10.1 Diamond Drilling**

Before TriStar, Barrick diamond drilled 2,027m of core in 23 drillholes. Checks of the collar locations of Barrick holes whose survey monuments can still be located confirm that the location uncertainty is small, in the order of 10m in the east-west direction. Re-assays of quarter-core from the half-core left from the Barrick exploration program confirm the reliability of the Barrick data.

TriStar drilled 144 diamond holes over three different drilling campaigns from 2011 to 2014. This work allowed the submission of the necessary reports to the ANM for the important areas on the plateau and the preparation of an initial mineral resource estimate.

Under new management in 2016, TriStar successfully drilled 12 diamond holes in the northern end of Esperança Center and southern extent of Esperança South to demonstrate the validity of the exploration target conceptual model, determining additional structural information and expanding the mineralization along strike.

In 2018, TriStar drilled an additional eight diamond drillholes at the north end of Esperança South, where rugged and steep topography made a man-portable diamond rig the safest and most efficient way to test the mineralized conglomerate band.

In 2019/2020, TriStar drilled 18 more diamond holes in Esperança South. Two of these holes tested the possibility that gold might have been concentrated in a remobilized front ahead of the basal intrusion, three holes were twins of shallow RC holes to test short-scale variability close to the surface, bias in gold grade and the remainder were drilled for exploration purposes.

In 2021, TriStar drilled 4 diamond holes in Esperança South and 1 hole in an exploration target.

Most diamond drilling was carried out using HQ diameter (63mm) core. For depths beyond 80– 100m, NQ diameter (47mm) core was used.

10.2 Reverse Circulation Drilling

In 2017, TriStar undertook a drilling campaign consisting entirely of RC drilling using three drill rigs over a six-month period from March to September. Two of these rigs were provided by Geosedna Perfurações Especiais S/A (Geosedna) and one was provided by GeoLogica Sondagens Ltda (GeoLogica). The Geosedna holes were 127mm in diameter and the GeoLogica holes were 139mm in diameter.

During this campaign, TriStar drilled 133 RC holes to infill between the diamond holes in a dense enough pattern that would allow an updated resource to be estimated in accordance with NI43-101 and CIM standards. RC drilling has the advantage of being faster and cheaper than diamond drilling but has the disadvantage of collecting only rock chips, not the integral cylindrical cores of rock collected from diamond drillholes. To mitigate this, TriStar employed DGI Geoscience, a Toronto-based company, to take continuous high-resolution OTV photographs of the inside of the drillholes and display them using WellCAD software. This 'virtual drill core' could then be examined for structures and other important sedimentological information in detail. Three twin RC holes were drilled at the same collar location and

Pre-Feasibility Study

orientation as TriStar’s diamond drillholes DH-40, DH-44 and DH-104 to compare and verify assay results. All other RC holes were drilled vertically.

The 2017 RC drilling was planned on a 100 x 100m “rhomboidal” grid pattern on the south-western limb of Esperança South, and the northern extent of Esperança Center, and on a 50 x 50m grid in areas previously drilled to satisfy ANM requirements for final exploration reports.

In 2018, 34 RC holes were drilled. These filled in gaps in Esperança Center and Esperança South; they also provided the first significant testing of Esperança East.

The purpose of the 2019, 2020 and 2021 RC drill campaign was to infill between existing holes to increase confidence from inferred to indicated classification. 233 holes were included in this resource update. The initial phase of drilling was performed by Geosedna before switching to Servitec Foraco mid-campaign.

10.1 Summary of Drilling

A summary of the drilling is provided in Table 10-1.

Table 10-1 Summary of the drilling campaign completed in the Project.

Hole Type	Title Holder	Year	No. of holes	Total (m)
Diamond	Barrick	1996	23	2,027
Diamond	TriStar	2011	22	4,003
Diamond	TriStar	2012	71	8,100
Diamond	TriStar	2014	51	4,110
Diamond	TriStar	2016	12	2,828
RC	TriStar	2017	133	15,019
Diamond	TriStar	2018	8	962
RC	TriStar	2018	34	3,973
RC	TriStar	2019	83	9,324
Diamond	TriStar	2020	19	2,371
RC	TriStar	2020	136	12,708
Diamond	TriStar	2021	5	620
RC	TriStar	2021	14	1000
Total			611	67,044

10.1 Sampling

10.1.1 RC Sampling

A sampling of RC holes is done by initial split at the drill rig using a Metzke riffle splitter at a proportion of 75% and 25%. The 25%, approximately 7.5kg sample in weight for the 1m sample intervals used in

Pre-Feasibility Study

RC holes, was bagged for assay. The remaining 75% was also bagged and stored on-site for reference, organized by drillhole number and depth.

Representative rock chips were collected during the drilling and logged on-site by a geologist to establish the stratigraphic context of the sampling and to provide a geological description of each sample. These have been stored along with the archived diamond drill core in the core storage area beside the camp office.

TriStar undertook a field trial of OTV technology, using the services of Toronto-based firm DGI Geoscience to take high-definition photos of the inside of the RC drillholes. In addition to using the chips to log the RC holes, on-site geologists also used these OTV images to help refine the logging of RC holes. Several diamond holes were also imaged by OTV to calibrate the logging techniques.

10.1.2 Core Sampling

HQ core samples were halved using a core saw with one half sent to a laboratory to be assayed; the other half was retained in the core box for quality control and verification purposes. Where resampling needed to be done, the half core that remained in the box was quartered and sent for re-assay, leaving the other quarter in the core box.

In early holes, from 2011, sample intervals were mostly 1m wide, but in 2012-2014 sample intervals were generally 2m, with shorter intervals being used where important geological changes were recognized.

Since 2016, all sample intervals in diamond drillholes have been 1m except where lithological contacts dictate slightly shorter or longer sample intervals.

10.1.3 Core Logging

All drill core during the 2011–2014 programs was logged using the lithological codes developed by TriStar at the beginning of its first drilling program in 2011. The geologists were asked to note the major lithology type and alteration intensity. A rock quality designation (RQD) was recorded in the earlier holes. Recoveries were generally excellent with complete core recovery in most runs.

From 2016 onwards, on advice from Rael Lipson, a more thorough logging system was put in place that required geologists to note clast sizes, basal contact, gradation, hydrothermal alteration, fabric, gold occurrence, geological structure, roundness, sorting, grain size and lithology. Using this new logging template, several older holes were also relogged.

10.1.4 Assay Accuracy and Reliability

There are no known factors that could materially impact the accuracy of the assay results. With most of the gold being free, and some of this being coarse, assay results are affected by the “nugget effect” issue, and often show considerable variability in duplicates and replicates. This variability is considerably lower in the RC drillholes where large volume (1 kg) Leachwell cyanide-leach assays were done. The nature of the nugget effect issue makes the drillhole assay database conservative in the sense that

Pre-Feasibility Study

some of the very low-grade intervals might have returned higher assays had they been re-assayed, but all the high-grade intervals were re-assayed.

The RC holes were the focus of the petrophysical logging program, which included a caliper log. Almost all of the RC holes show little variation in diameter, a reflection of the high RQD of most of the silicified rock. Two of the RC holes caved in the friable upper arenite and had to be abandoned.

The visual logging protocols for RC drilling included a column for recording whether the samples were wet or dry when they reached the surface. In 41,024 meters of RC drilling, 1526 samples (4%) were reported as wet. Comparisons of grades from wet sample intervals and dry sample intervals do not show any systematic bias in the wet intervals, nor any smearing of gold grades along the hole. Comparisons of grade profiles in three pairs of twinned core-RC holes show that the assay data from RC is reliable. Lithology logging suffers in RC holes, where it is harder to distinguish lithologies from chips; but the availability of optical televiewer images mitigates this problem and allows reliable lithology logging in all the RC holes that were accessible to the optical televiewer instrument.

Field duplicates from the RC drilling program confirm that the sample splitters at the head of the three drill rigs were all functioning well, with no bias between the first split that was sent to the lab and subsequent splits that were used as field duplicates.

10.2 Surveying

10.2.1 Collar Surveying

TriStar drill collars were initially surveyed using one of two handheld GPS devices, either a Garmin GPS map 78S or a Garmin eTrex touch unit, immediately following the completion of a drillhole. Later, TriStar re-surveyed the collars with a GPS Pro Mark 500 for more accurate coordinate readings.

10.2.2 Downhole Surveying

Downhole surveying was performed using either the EZ-Shot system from Reflex or using the Maxibor system from Reflex. Many of the shorter holes were not surveyed down the hole; for these, their downhole orientations are calculated from a single survey of the orientation of the hole at the collar.

For the RC holes, Advanced Logic Technology's OTV tool used by DGI Geoscience includes instrumentation that measures the azimuth and inclination of the hole. Except for three RC holes that were oriented parallel to an adjacent core hole, all the RC holes were drilled vertically; the down-hole surveys acquired to support the optical televiewer images confirm that there is almost no horizontal deviation in the vertical RC holes, less than two meters in all the holes that were surveyed to a depth of 120m.

Holes drilled in 2020 by drill contractor Servitec used a GFT (gravity face tool) from Trust suppliers.

Pre-Feasibility Study**10.3 Interpretation****10.3.1 Esperança South**

Esperança South is the area on the property with the highest grades. Almost every drillhole drilled along its 4.5km strike length intercepted gold above the resource reporting cut-off grade. This area is open along strike to the south and there is strong evidence of additional mineralization to the north in terrain that is currently not easily accessible to a large drill rig; this has been verified by a limited program of seven diamond drillholes with a man-portable rig, all of which showed multiple reefs of mineralization. The mineralization in the northern end appears to be offset by a major east-west fault.

In Esperança South, the strike of the mineralized conglomerate band bends, having an approximately northeast-southwest strike on its southwestern limb that swings to an approximately north-south strike to the north. Drillholes were drilled in a due east direction (090°) in the northern end while in the south the azimuth of each hole was 140° to intercept, as closely as possible, the mineralized beds at right angles to the strike. Almost all the holes are collared in the outcrop of the conglomerate band, and few penetrate the footwall of this band; estimates of the true thickness of the conglomerate band are based on surface mapping of the conglomerate band outcrop, adjusted to consider the dip of bedding. Through most of Esperança South, the conglomerate band has a true thickness of 250–300m.

10.3.2 Esperança Center

Esperança Center has been drilled along 2.5km of strike length and down to 120m depth. Like the northern end of Esperança South, the conglomerate band strikes in a north-south direction meaning all diamond holes were drilled due east (90°), with an inclination of -60° to intersect the conglomerate at right angles to the 30° west-dipping beds. Mineralization is open at depth. The southern extent of Esperança Center appears to be truncated by a major east-west trending fault offsetting mineralization eastward to Esperança East. In the northern end of Esperança Center, mineralization arches around to the west, mimicking the surficial exposure of the folded bowl structure, as evidenced by the soil sample anomalies. Mineralization in Esperança Center is different than in Esperança South; there are fewer no-detects in Esperança Center, but also fewer very high-grade assays, giving Esperança Center lower variability, a lower proportion of assays above the resource reporting cut-off grade, but a slightly higher average grade than in Esperança South.

10.3.3 Esperança East

As confirmed by mapping by Paul Karpeta in 2018, Esperança East is more structurally complex than Esperança Center and Esperança South, with bedding directions often changing quickly between the available outcrops. Generally, the mineralization dips to the west, consistent with the view that the Esperança East block is the bridge between Esperança Center and Esperança South.

Parts of Esperança East more closely resemble Esperança Center, with long runs of mineralization slightly below the resource reporting cut-off grade; other parts more closely resemble Esperança South, with grades occasionally exceeding 10 g/t over short intervals.

Pre-Feasibility Study**10.3.4 True Thickness**

Almost all diamond holes were drilled to intercept the mineralized beds at right angles, or as close as practically possible, in Esperança South and Center. As a result, many of the measured bedding core angles are generally high angles 70–90° to the long core axis. Therefore, the thickness of most intervals from diamond drillholes is very close to true thicknesses. In RC holes, which were drilled vertically, the apparent thickness of an interval observed in the hole is about 15% longer than the true thickness, due to a bedding dip that averages 25° to 35°.

Pre-Feasibility Study

11 SAMPLE PREPARATION, ANALYSES, AND SECURITY

TriStar drilling campaigns have consisted of diamond drillholes (2011–2016 and 2018) and RC holes (2017 and 2018) and have primarily involved three commercial laboratories: Acme (2011–2012), SGS/Geosol (2012–2017) and ALS (2017-2021) (Table 11-1).

Table 11-1 Commercial Analytical Laboratories utilized by TriStar

Laboratory	Year	Prep Lab Location	Analytical Lab Location	Certification
Acme	2011-2012	Itaituba, Brazil	Santiago, Chile	ISO9001:2008
SGS/Geosol	2012-2017	Paraupébas, Brazil	Vespasiano, Brazil	ISO9001:2009
ALS	2017-2019	Goiania, Brazil	Lima, Peru	ISO9001:2010
ALS	2020-2021	Goiania / Vespasiano, Brazil	Vancouver, Canada	ISO9001:2010

All laboratories and their employees are independent of TriStar. TriStar personnel and consultants and contractors were not involved in laboratory sample preparation and analysis.

Fire assays were used to establish gold grades for all the diamond drillhole (DDH) samples, and some of the samples from RC drillholes. Leachwell assays were used for most of the RC samples. In the sections that follow, the different sample preparation protocols used for DDH and RC samples are discussed first, followed by the different analytical procedures used by each laboratory. Quality assurance and quality control (QAQC) programs are then discussed, followed by commentary on sample custody and security.

Samples from Barrick drilling campaigns (1995 and 1996) were used in resource estimates. Archived core from this first drilling campaign on the Castelo de Sonhos plateau was still available in 2011 when TriStar began its work, along with electronic archives of Barrick data and documents. The reliability verification of Barrick assays is discussed in Section 12 (Data Verification).

When TriStar began its work on Castelo de Sonhos, the project archives contained no reports on analytical methods, sample preparation or QA/QC procedures in use during the Barrick exploration program. Excel spreadsheets do record assays done by three different labs: SGS, Nomos and Bondar-Clegg, with most intervals having assays from two or more labs. The archived spreadsheets also record the insertion of blank material at a rate of 1 in every 20 samples. With no reports that pertain to the reliability of the Barrick data, TriStar undertook a re-assaying program of two entire drillholes, taking ¼ core from the ½ core archives that remained from the Barrick drilling.

11.1 Bulk Density

A total of 28 density assays were conducted by GE21 in a 2018 campaign, with an average value of 2.68g/cm³ for dry density. Samples were selected by lithology and mineralization from diamond drillhole cores for density determination by the water displacement method. Tests were conducted with half-core samples, with a minimum of 10 centimeters of length per sample. Samples were dried at 105°C for 120

Pre-Feasibility Study

minutes, weighed, coated with a thin layer of wax to prevent water impregnation and then weighed inside and outside water (Figure 11-1)

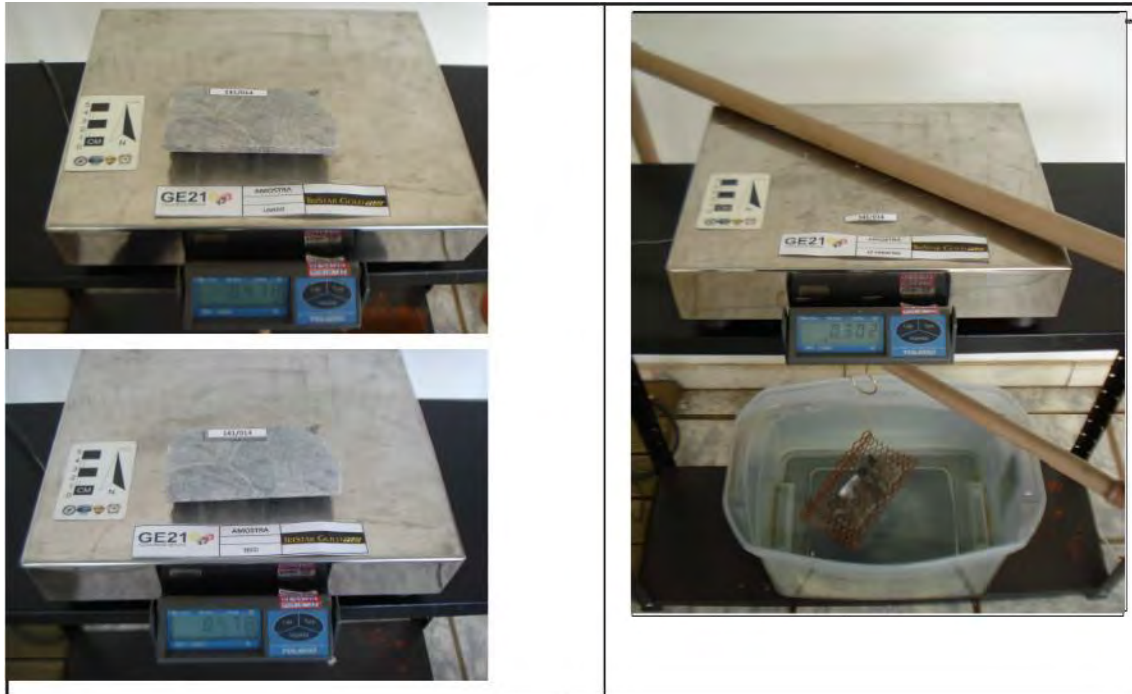

Figure 11-1 Density determination for sample 141/014

The density value is measured using the formula:

$$\rho_d = \frac{M_s}{(M_{s+wax} - M_{s+wax \text{ in water}}) - \frac{(M_{s+wax} - M_s)}{\text{Density of wax}}}$$

Where: **M_s**: sample dry weight; **M_{s+wax}**: waxed sample weight; **M_{s+wax in water}**: waxed sample weight in water. **The density of wax: 0.7795 g/cm³**.

Specific gravity determinations have been made mostly in fresh rock samples, considering the light weathering alteration level on project lithologies. It is recommended an extensive campaign of density test work to improve the density of information across the deposit.

11.2 Sample Custody Security

Drill samples collected by TriStar geologists were placed in plastic bags that were tagged and sealed (Figure 11-2). These were grouped into batches for shipment to the preparation lab, using large sacks. Each laboratory batch would consist of a few large sacks, each of which typically contained a few dozen individual sample bags. The sacks were also sealed and labelled to indicate how many large sacks belonged to the same batch. TriStar's external QAQC samples (field duplicates, blanks and CRMs) were included in the sacks at the site by TriStar geologists.

Pre-Feasibility Study

Figure 11-2 Drillhole samples collected and bagged in the core storage area at the site

Batches awaiting shipment were stored on-site, typically for two to three weeks until several batches were transported together, by closed truck, to the preparation lab. The seals on the sacks and bags were broken at the preparation lab, which reported back to TriStar on the samples it received and logged into its laboratory information management system.

Through many years of drilling, there have been no samples lost in transit, or additional samples received that were not part of what TriStar recorded as having been shipped. There have also been no cases of the individual sample bags being damaged or leaking, or of sample tags being missing or illegible; sample integrity has remained excellent throughout the drilling programs.

At the preparation lab, pulp material was prepared for analysis and transported by commercial air freight to the analytical laboratory, where the samples were again inventoried and checked against the prep lab's records.

11.3 Laboratory Sample Preparation

11.3.1 Diamond Drillholes

Drill cores from diamond drillholes were transported, by truck or all-terrain vehicle, to the core storage and logging area, where it was photographed and sawn. Half of the core was bagged for shipment to the laboratory and the other half was retained at the site; some of the half-core has been used for other studies, such as further QAQC checks or metallurgical test work and is now reduced to quarter-core at the site. For TriStar drilling campaigns from 2011 to 2014, cores were sampled in 2m intervals. For drilling campaigns from 2017 to 2021 cores were sampled in 1-meter intervals. Shorter intervals were sometimes sampled (at a minimum of 0.5 meters per sample) where significant changes in geological characteristics were noted.

Pre-Feasibility Study**11.3.2 Reverse Circulation Drillholes**

Samples from TriStar RC holes were collected every meter, with a Jones splitter attached to the RC rig being set to deliver approximately 25% (for the 2017 campaign) and 12.5% (for 2018 to 2021 campaigns) of chips to the buckets that were then bagged for shipment to the laboratory. The remaining chip material was stored on-site for use in further studies, and a small collection of chips from each interval were retained for viewing purposes in the core storage area.

11.3.3 Lab Preparation for Fire Assays

The entire sample received by the lab was dried and crushed to 2mm using a jaw crusher, with the exact specification for crushing being slightly different for each of the primary labs that did fire assays:

- 85% less than 2mm was used by Acme, which handled the samples from August 2011 through March 2012;
- 95% less than 2mm was used by SGS/Geosol, which handled the samples from August 2012 through May 2017;
- 90% less than 2 mm was used by ALS, which handled samples from May 2017 through the time of this report;
- After homogenization of the crushed material, the preparation lab took a subsample and pulverized it:
 - Acme took a 500g subsample of the homogenized crushed material and pulverized it to 85% less than 75 microns (200 mesh);
 - SGS/Geosol took a 200–300g subsample of the homogenized crushed material and pulverized it to 95% less than 100 microns (150 mesh);
 - ALS took a 1kg subsample of the homogenized crushed material and pulverized it to 95% less than 100 microns (150 mesh).

Pulverized material was then shipped to the analytical laboratory.

11.3.4 Lab Preparation for Leachwell Assays

ALS is the only lab that has done Leachwell assays for the Castelo de Sonhos Gold Project, using their prep lab in Goiania, Brazil, and their analytical laboratory in Lima, Peru. To date, Leachwell assays have been done on samples from RC holes and diamond holes.

ALS preparation for Leachwell assays followed the same steps as described above for the few fire assays done by ALS. Preparation lab dried and crushed the entire received sample to 90% passing 2mm. After homogenization of the crushed material, a 1kg subsample was taken and pulverized to 95% less than 100 microns (150 mesh). The pulverized material was then shipped to the analytical laboratory in Lima, where the entire 1kg was analyzed using the Leachwell procedure.

Pre-Feasibility Study

11.4 Sample Analysis

11.4.1 Fire Assays

The conventional fire assays done for the Castelo de Sonhos Project (by Acme, SGS/Geosol or ALS) have all used 50g aliquots with an atomic absorption spectrometry finish.

11.4.1.1 Leachwell Assays

ALS does Leachwell assays using a four-hour vessel rotation of a 1kg pulp in cyanide solution that accelerates leaching using Leachwell assay tabs manufactured by Mineral Process Control, the developer of the Leachwell technology. An atomic absorption spectrometry finish is used to measure the mass of gold in solution and to calculate the head grade of the original sample, assuming that none of the gold is left in the residue.

11.5 Quality Assurance and Quality Control (QAQC)

All laboratories used by TriStar are ISO certified and have internal QAQC programs for monitoring the accuracy and precision of analytical results provided to clients. In addition to the lab’s internal QAQC programs, TriStar also runs its external QAQC program that includes standards, blanks and duplicates inserted into the sample stream at the Project site, before shipment to the preparation lab. Table 11-2 summarizes the number of QAQC samples that TriStar has included in the sample stream.

Table 11-2 External QAQC samples included at the site by TriStar in the sample stream

Sample Type	Nº. of samples	Insertion rate
Regular samples	55,113	
Certified reference materials (CRMs)	1,386	1 in 40
Prepared Reference Materials (PRMs)	2,294	1 in 24
Blanks	1,392	1 in 40
Field duplicates	1,161	1 in 35

11.5.1 Analysis of Standards

From the start of TriStar’s drilling in 2011 until 2017, there have been 13 instances (1%) where the assay of a standard was more than 10% above or below its certified reference value. Two of these are likely sample mix-ups, either at the site or in the lab. Of the remaining 11, only one of them was off by more than 20% (a low assay on one standard in the fall of 2016). In 2017 TriStar switched to ALS labs to rectify errors in blanks and standards reporting. From 2017 to 2021 there have been 23 failed standard samples analyzed (4%), apparently related to misreferenced CRM types (ITAK-600, ITAK-601 and ITAK-611).

11.5.2 Prepared Reference Material (PRM)

Prepared reference material (PRM) was inserted in CDS Project at the beginning of 2019, as an accuracy controlling tool. PRMs were inserted in the expedition step after they are prepared. PRM consists in producing a specific sample blending CRM content with approximately 500g of non-mineralized material from project RC sampling. TriStar used 4 different commercial CRMs (ITAK-536,

Pre-Feasibility Study

ITAK-657, ITAK-611 and ITAK-636) in PRM sample preparation. Grade calculation for PRM samples is based on the formula:

$$\text{CRM Weight} / (\text{Final Weight} - \text{Bag Weight}) * (\text{CRM Grade})$$

Decision on changing from CRM (Certified Reference Material) to Prepared Reference Material (PRM) was made considering the use of project matrix material on standard samples, the similar amount of PRM samples with routine samples and the fact that PRM samples go through every laboratory preparation step including crushing preparation, and analytical procedures.

Until July 2021, grouping by function generated 143 groups. PRM samples with a variation greater than 10% from the mean are considered failed (Figure 11-3). Since the initial use of PRMs, 84% of control samples were approved.

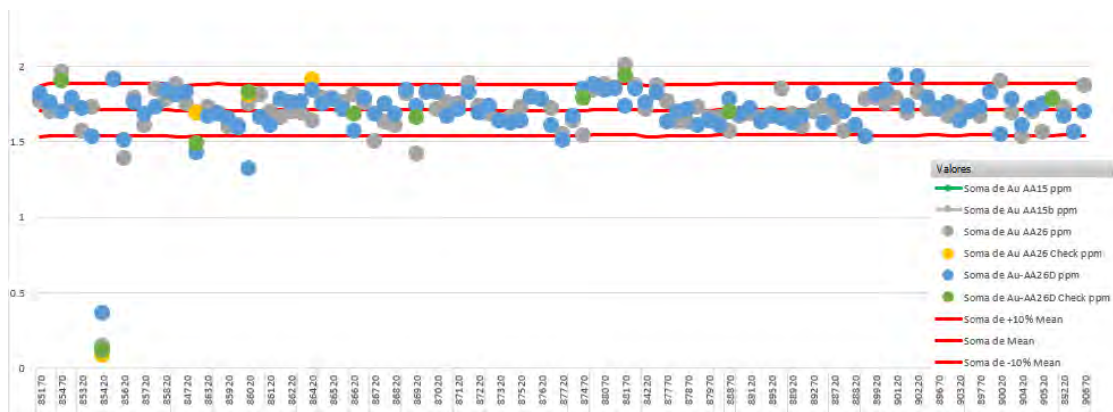

Figure 11-3 Control chart for PRM prepared with ITAK-536 for 2020

11.5.3 Duplicate Analysis

Figure 11-4 shows a scatterplot of assays from field duplicates. Field duplicates of fire assays and Leachwell show a high correlation. A correlation coefficient of 0.94 and 0.95 is considered satisfactory, given such samples being entirely separate when bagged and tagged at the site and prepared, processed, and analyzed as entirely independent samples.

Pre-Feasibility Study

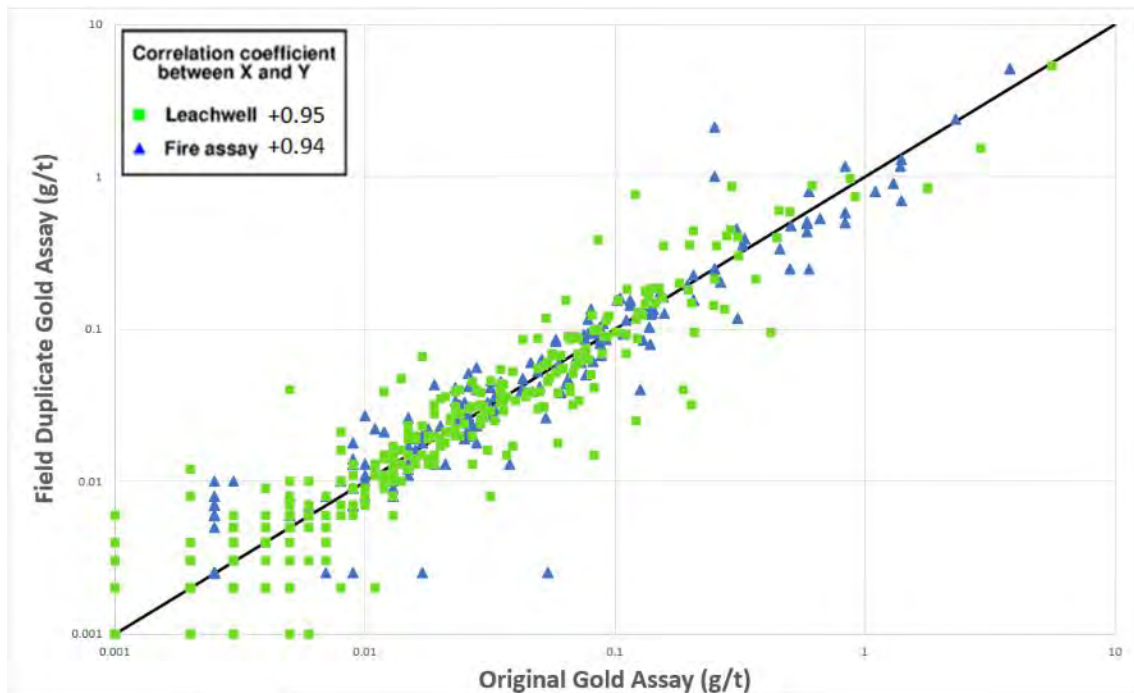

Figure 11-4 Comparison of gold assays from field duplicates; samples analyzed by fire assay are shown in blue, those analyzed by the Leachwell method are shown in green

11.5.4 Blanks Analysis

Since the start of TriStar’s drilling in 2011, only five of the blanks (<1/2%) have returned assays with more than 10x the detection limit of 0.005g/t. After TriStar switched labs to rectify errors in blanks and standards reporting as well as started using commercial blank samples (ITAK-QF-03, ITAK-QF-09 and ITAK-QF-11), 2 blank samples returned assays with more than 10x the detection limit of 0.005g/t (apparently a case of mislabelled samples).

11.5.5 Metallic Screen Assays

In addition to the external QAQC samples summarized in Table 11-2, TriStar has also done metallic screen assays of 2,297 of the intervals that had fire assays. Although there is coarse free gold in the Castelo de Sonhos samples, metallic screen assays give similar results to the conventional fire assays.

Figure 11-5 shows a plot of samples comparing fire assay and metallic screen results. For both group of data, the correlation is very good: 0.94 for SGS-Acme and 0.97 for Acme-Acme, with only two outliers in almost 500 checks. TriStar decided to continue to use conventional fire assays through its diamond drilling programs.

Pre-Feasibility Study

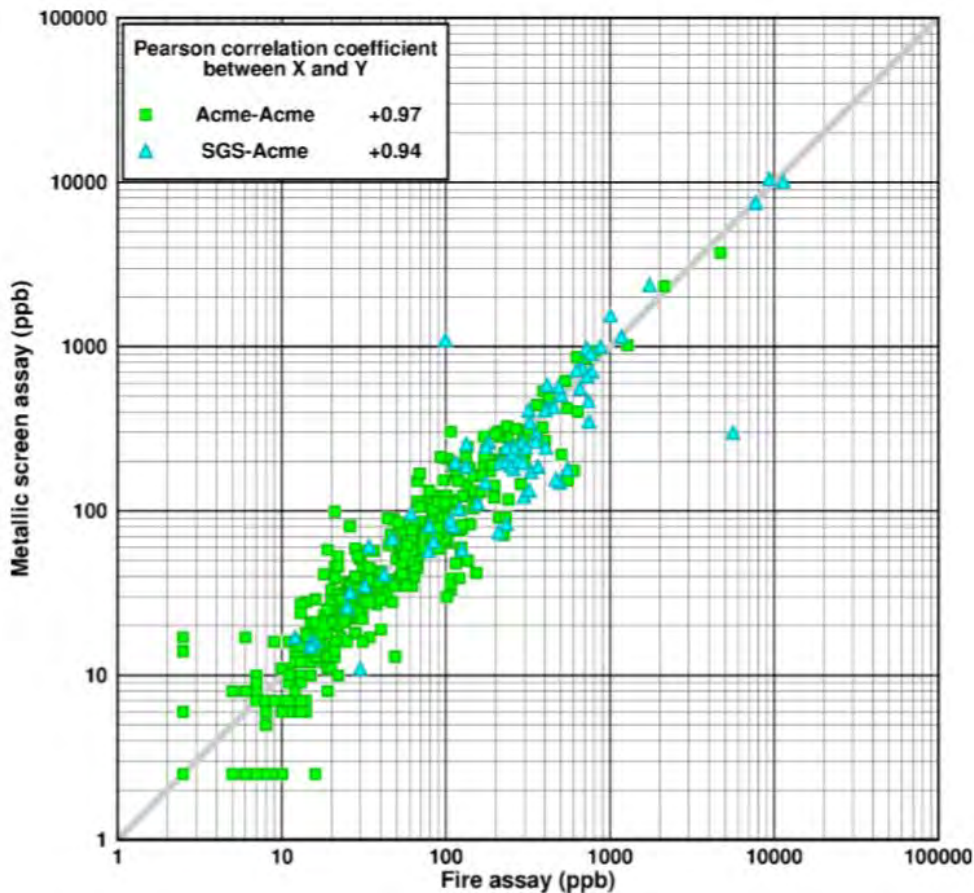

Figure 11-5 Comparison between results of conventional Fire Assays and Metallic Screen Assays. Green squares show samples for which Acme did both assays; blue triangles show samples for which SGS did the Fire Assay and Acme did the Metallic Screen Assay

11.5.6 Leachwell Assays

Leachwell procedure uses an aggressive cyanide leach to extract gold from pulverized rock. The principal advantage of this method is that it analyses a much larger mass of material than conventional fire assay. In the case of the Castelo de Sonhos samples, Leachwell assays were done on 1kg of pulp, 20 times the mass of the 50g aliquots analyzed in fire assay and 6 times the mass analyzed in metallic screen assay. Analyzing larger masses of material helps to reduce assay variability caused by nuggets of free gold in the sample.

TriStar adopted Leachwell procedure in 2017 and found that this method does produce more reliable assays:

- Of 705 blanks run through the Leachwell procedure, only 2 of them returned grades more than 5x the detection limit (apparently mislabeled samples).
- For CRMs, the variability of Leachwell assays was lower than fire assays. The average grade matches the reference value much more closely. For high-grade CRM, for instance, the variance from Leachwell assays was less than half of the fire assays on the same material; the average

Pre-Feasibility Study

of Leachwell assays matches the certified reference value to the second decimal place, 5.65g/t, while the average of the fire assays runs slightly high at 5.78g/t;

- The scatterplot of field duplicates (Figure 11-4) also indicates that Leachwell assays have better precision than fire assays: the spread of fire assays sample pairs (blue triangles) around the X=Y line is broader than that of Leachwell assays (green squares).

11.6 Adequacy of Procedures

The QP is of the opinion that sampling collection, sample preparation, assay procedures and QAQC results are inside acceptance limits of mineral industry standards for purpose of mineral resource estimates.

Pre-Feasibility Study**12 DATA VERIFICATION****12.1 Verification of Drillhole Data****12.1.1 TriStar assay data**

From the time it took over the project in 2011, TriStar has maintained a complete archive of the project's assay certificates, all of which have been provided in an electronic format by the laboratories. The MX Deposit database records the sample number and assay certificate number for every interval, making it easy to retrieve the original certificate for any assay done under TriStar's direction. It also records information on which assays have been used to create the "Au_model" field, following the hierarchy shown in Figure 14-2, which facilitates the checking of multiple assay certificates when the gold grade used for resource estimation is an average of two or more assays.

In each of the previous historical resource estimates, one of the QPs has checked the digital database used for resource estimation against original certificates for a subset of the drillholes, typically 1–2% of them, containing several hundred assays. No discrepancy has ever been detected between assay certificates and the digital database used for resource estimation, and there has been no instance where the hierarchy for the use of multiple assays has been misapplied.

With no errors or discrepancies having been found, the QP for resource estimation is of the opinion that the Castelo de Sonhos drillhole assay database has a very high degree of integrity and is supported by ancillary information that facilitates tracing all assay information back to the original laboratory certificates.

12.1.2 TriStar collar coordinates

Locations of new drillholes have been verified using the new LIDAR topography and the aerial photographs taken during the LIDAR survey. The aerial photographs were collated into a single georeferenced orthophoto that has a very high resolution; its individual pixels are 0.1 x 0.1 m. Drill pads from the 2019–2020 drilling campaign can easily be identified on the orthophoto. For 21 of the new drillhole collars (10%), the digital version of their collar location was checked against the orthophoto to confirm that there is a visible drill pad at the location recorded in the collar file; in all instances, the visual evidence of a drill pad confirmed the location in the digital data base to within a few meters in map view.

The elevation of a drillhole's collar is usually more uncertain than its X, Y location in map view, especially when measured by a single reading from a hand-held GPS device. The LIDAR topography provides measurements of the elevation of the ground surface that are consistent: all the elevations were acquired using the same technology within a few days. The LIDAR topography also has very high precision, within ± 0.5 m. For the purposes of resource estimation, each hole collar was set to the LIDAR topography elevation at the Easting and Northing location of its collar. With all collars referenced to the consistent LIDAR topography, any errors that might have existed in GPS elevation measurements of hole collars have been removed.

Pre-Feasibility Study**12.1.3 Barrick assay data**

Although a digital version of the 1995-1996 Barrick drillholes database was available to TriStar when it assumed control of the project in 2011, the original assay certificates from the Barrick campaigns were no longer available. To verify the reliability of the Barrick assay data, TriStar took the ½-core that remained from Barrick's drilling and submitted ¼-core samples for reanalysis. Figure 12-1 shows the comparison of the assay values recorded in Barrick's digital database to the new assays done by TriStar.

Pre-Feasibility Study

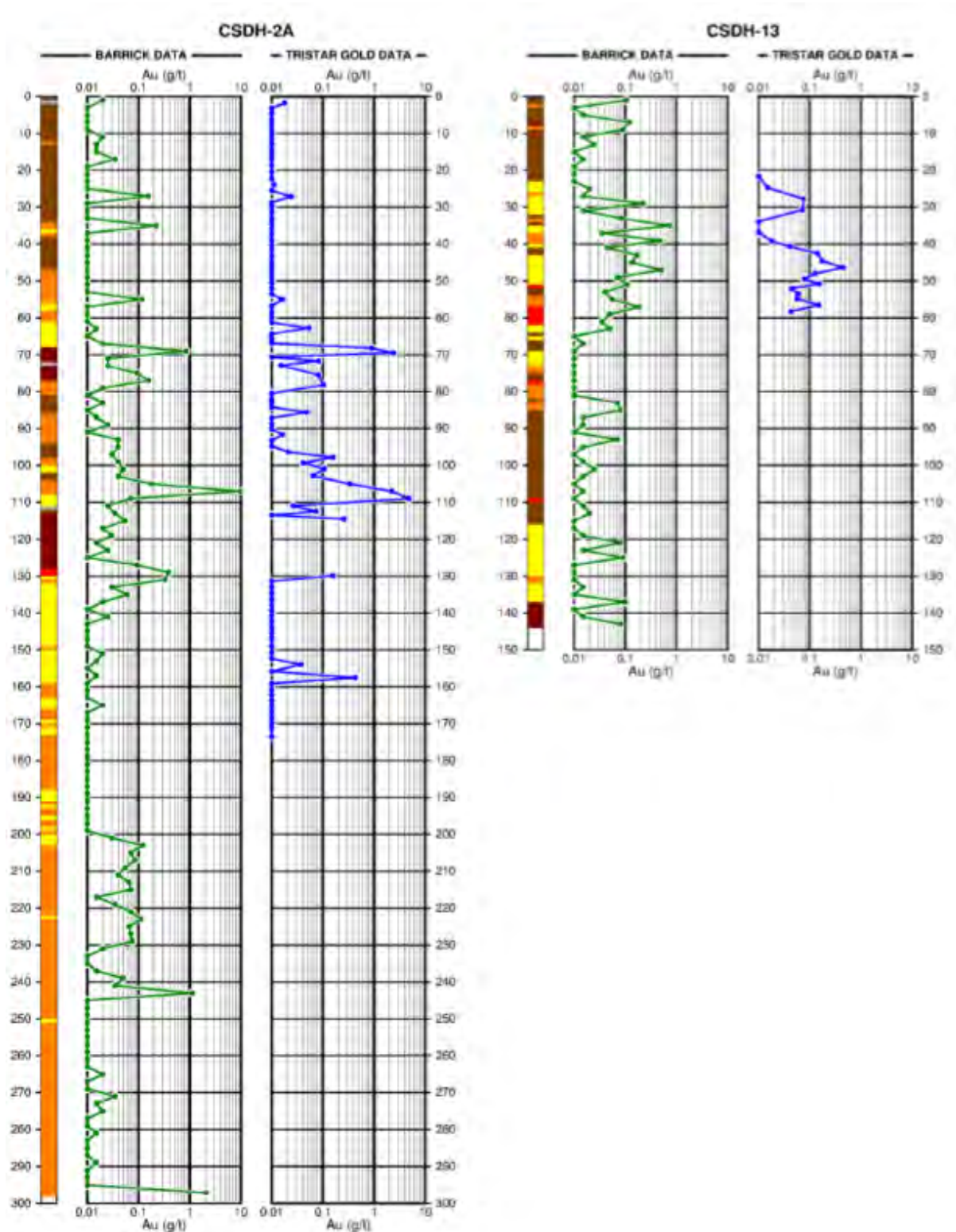

Figure 12-1 Comparison of Barrick ½-core assays to TriStar ¼-core assays, with Barrick assays having been composited to the 2m intervals sampled by TriStar.

Pre-Feasibility Study

With the strong agreement between more than 150 checks of new ¼-core assays to old ½-core assays, the QP for resource estimation regards the Barrick data as being reliable for the purposes of resource estimation.

12.1.4 Barrick collar coordinates

For two of the 23 Barrick hole collars, their collar monuments still exist in the field; for the other Barrick holes, their collar monuments were destroyed by small-scale artisanal mining that often used Barrick hole collars as locations to begin mining.

For the two Barrick holes whose collars can still be surveyed, the Easting recorded in Barrick's files differed by an average of +12m from the Easting measured by TriStar, and the Northing differed by +1m. The collar locations recorded in Barrick's digital database were shifted 12m to the west and 1m to the south to adjust for the small bias seen in the two-hole collars for which new GPS measurements could be done.

Following the small adjustment to the Easting and Northing of its collar, each Barrick hole was assigned the elevation of the LIDAR survey at its collar.

The assays and locations of Barrick holes, many of which lie close to TriStar holes, have been checked by plotting them on cross-sections with holes drilled much later and viewing them in a 3D visualizer. No significant discrepancies have been noted.

12.2 Verification of Topography Data

The topography files used for previous resource estimates were assembled from different sources of data that were digitally merged. These have all now been entirely replaced with the LIDAR topography, a single plateau-wide, high-resolution survey done in August 2020, giving the project a consistent single source of information on the elevation of the ground surface.

Since LIDAR technology measures relative height, it needs to be calibrated to ground-control points that have been accurately and precisely surveyed. At the beginning of the LIDAR survey, when ground-control survey locations were being established, TriStar requested that the LIDAR contractor's ground crew survey 25 locations in addition to those that they were going to survey for use as LIDAR ground-control points. Eight of the locations chosen by TriStar now serve as survey monuments across the plateau that can be used in future to field-check any GPS device against a permanently marked location with 1st order survey precision. The other 17 of TriStar's locations are hole collars.

When the final LIDAR topography database was delivered to TriStar, the XYZ files were checked against the 22 ground-control points and against the 25 additional locations chosen by TriStar. For the 22 ground-control points, the differences between the surveyed elevation and the LIDAR elevation at those locations were all less than ± 0.1 m; this confirms that the post-processing of the raw LIDAR data correctly tied the LIDAR elevations to the ground-control points. At the other 25 locations, the ones chosen by TriStar, the differences between the surveyed elevation and the LIDAR elevation were larger, but all less than ± 0.5 m. The larger error confirms that the locations chosen by TriStar were not used as ground-control points and that they are genuine validation points, independent of the LIDAR data. With the

Pre-Feasibility Study

surveyed elevations at the TriStar locations all being within $\pm 0.5\text{m}$ of the LIDAR elevations, the claimed sub-meter precision of the LIDAR survey has been verified.

12.3 Adequacy of Data

The QP responsible for the current resource estimate is of the opinion that the drillhole and topography databases have been compiled and maintained well and that the data is adequate for the purposes of resource estimation.

12.4 Site Visit

Technical visit to project site was performed by the geologist Leonardo Soares and mining engineer Guilherme Gomides, who are QPs, between 26th and 27th of May 2021. During the technical visit the follow points were verified:

- Coreshed and drillhole intercepts with sampling registers.
- Geomechanical parameters related to the rock mass properties in the project as fracturing condition, orientation and spacing, weathering and strength of rock mass.
- Drillhole landmarks and topography registers.
- Outcrops along mineralization zones where garimpo pits were developed.
- Areas or waste pile installation.
- Drillhole logs at project office.

All the verifications results show that field conditions and checked information and registers are in accordance with premises and parameters of the Castelo de Sonhos Project for a pre-feasibility study level of confidence.

Pre-Feasibility Study

13 MINERAL PROCESSING AND METALLURGICAL TESTING

13.1 Introduction

Metallurgical testing has been ongoing since 2014, primarily focused on Esperança South. The majority of the work has been carried out under the direct control of TriStar at McClelland Laboratories in Sparks, Nevada (“MLI”) addressing “whole ore” agitation leaching and various combinations of gravity concentration and flotation with cyanidation of concentrate and tailings products.

Based on results so far TriStar has identified a “Base Case” flowsheet for project development. It includes crushing, grinding, whole ore hybrid cyanidation and carbon in leach.

Agitation leaching has been tested with bottle rolls over a range of grind sizes at cyanide concentrations of 0.5 and 1.0g/l, overall results are summarized in Figure 13-1.

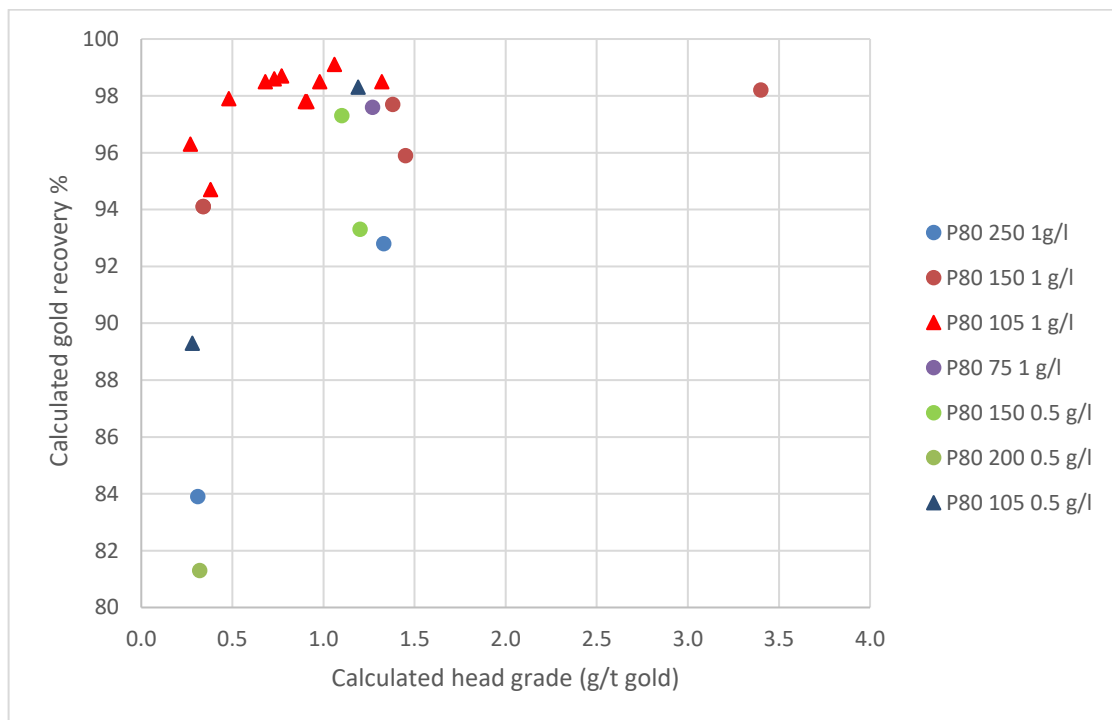

Figure 13-1 “Whole Ore” Cyanidation at Various Grind Size and Cyanide Strength

Trade off studies will be required to optimize grind size, reagent strength, metal price and recovery as the project moves into detailed design. Simple inspection of the test results to date confirmed the conditions adopted for this study, P₈₀ 105 microns, Cyanide strength 1.0 g/l. Pertinent tests are isolated in Figure 13-2 and indicate recoveries at or above 98% over a range of head grades typically expected across the deposit. It is recommended that 98% recovery be used to evaluate preliminary project economics

Pre-Feasibility Study

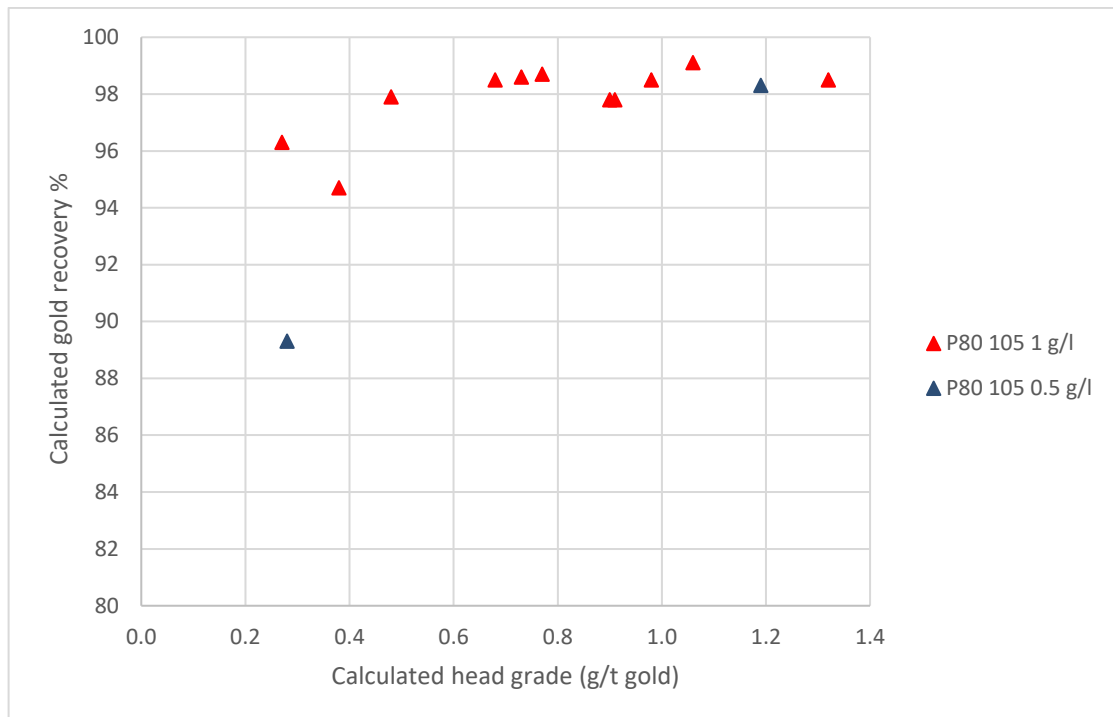

Figure 13-2 “Whole Ore” Cyanidation at P₈₀ 105 microns and 1.0 g/l Cyanide

13.2 Previous Testwork by Others

Limited metallurgical testwork referenced in the 43-101 Technical Report issued by RBM Consultoria, dated September 22, 2014, was carried out by SGS/Geosol, at their facilities in Vespasiano, Minas Gerais, Brazil. Results are summarized in their report “Caracterizacao Tecnologica Em Uma Amostra De Minerio De Ouro” Revision 1, dated 26/06/2014.

Grinding, gravity concentration and cyanide leach testing was performed on a composite sample assembled from drill core rejects collected along the length of Esperança South.

Forty-one core samples collected from twelve drillholes (CSH-41, 43, 44, 47, 57, 58, 59, 80, 81, 83, 85 and 87) that had been crushed previously to minus two millimetres, were combined to produce a 52kg composite which was dried and split to produce 1kg subsamples for analysis and testing. It is not clear how representative the composite was of the deposit, but it was relatively high grade, assaying 3.11g/t. Analysis by size fraction revealed that 41.5% of the gold was coarser than 250 microns.

Testing was initially carried out on subsamples ground to 80 percent passing (“P₈₀”) 150 and 53 microns. Gold recoveries from gravity testing 10 kg lots in a Falcon centrifugal concentrator were 73.0 and 88.6% respectively. Associated mass recoveries were 0.72 and 0.85%.

Gravity tails were sub-sampled and leached in bottle rolls with cyanide for 24 hours. Overall gold recoveries (gravity plus cyanidation) increased to 95.9% (at 150 microns) and 99.6% (at 53 microns). Reagent usage was relatively low, sodium cyanide consumption ranged between 605 and 649g/t and lime between 150 and 200 g/t.

Pre-Feasibility Study

Bottle roll testing of the original composite at minus two millimetres for 24 hours resulted in gold recovery of 78.7% with cyanide and lime consumptions of 455 and 200 g/t respectively.

Results indicate that the material tested was amenable to either gravity concentration or cyanidation or a combination of both.

13.3 Phase One Testwork

Preliminary metallurgical testing was carried out at McClelland Laboratories Inc., (“MLI”) in Sparks, Nevada, USA during the first half of 2017. Their Report “Preliminary Metallurgical and Comminution Testing, Castelo de Sonhos, MLI Job No. 4160” dated June 8, 2017, which describes test methods, protocols and results may be summarized as follows.

13.3.1 Sample Collection

A bulk sample comprised of 163 kg of one quarter drill core was collected late in 2016 from Esperança South. A total of 63 intervals were selected from eleven holes (CSH-11-003, 018, CSH-12-036, CSH-14-103, 116, 118, 119, 121, 127, 133 and 138), running the length of the deposit as it was known at that time. The intent was to represent rock type distribution across the deposit while targeting a projected gold grade of 1.5 g/t. Rock types mC1 and mC2 which represented the majority of the deposit made up 55 and 24% of the sample respectively. The intervals were placed in plastic bags, tagged and shipped in sealed drums to MLI for analysis and testing.

13.3.2 Sample Preparation

Upon receipt at MLI the samples were inspected and weighed. There was no evidence of damage to the containers or interference with the material in transit and shipped/received weights agreed within 1.5%.

Under the direct supervision of TriStar Gold a total of 22 kg of core was selected at random from all eleven holes. Material was classified as near surface, mid depth and deep and was composited into a single sample (Composite 4160-002) for Bond Grinding and Abrasion testwork.

All remaining material was combined to produce a separate sample (Composite 4160-001) which was subsequently crushed to minus 10 mesh, blended and subsampled to produce 1 kg aliquots for analysis, assay and testing (cyanidation, gravity and flotation concentration).

13.3.3 Analysis and Assay

Metallic head screen analyses on Composite 4160-001 indicated 1.3 g/t gold (compared to the target 1.5 g/t) and less than 3 g/t silver. (The latter was to confirm what was already known from the drilling program assays). While there was some upgrading of gold in the “metallic” fraction (screened at 105 microns after pulverization) the grade of that fraction (20.3 g/t) and the gold distribution of the sample (only 11.8% of contained gold reported to the coarse fraction) indicated that coarse particulate gold did not represent a significant portion of the gold in the sample, this was substantiated in testing. Quantitative analysis for copper and silver indicated 20g/t and less than 1 g/t respectively, a multi

Pre-Feasibility Study

element scan subsequently reported 3.5 g/t and less than 0.1 g/t respectively. There were no obvious cyanicides of concern in the sample.

13.3.4 Bond Grinding and Abrasion Testing

The entire grinding and abrasion sample was crushed to minus 0.75 inches and screened on 0.5 inches to produce sample for abrasion testing. Abrasion test products and rejects were combined and crushed to minus 6 mesh to provide feed for grinding tests. Testwork was carried out using standard Bond procedures and equipment. Tests were run in duplicate to check for variability. Abrasion index ("Ai") was reported at 0.3667 and 0.3339, metric bond ball mill index ("BWi") was reported at 13.74 and 13.50 kWh/t.

13.3.5 Whole Ore Cyanidation

Standard bottle roll cyanidation tests were carried out on 2 kg samples stage ground to 80% passing ("P₈₀") 250, 150, 105 and 75 microns with 40% w/w slurry, 1.0 g/l NaCN, pH 10.5. Gold recovery from the coarsest (250 micron) feed was 92.8% and increasing when leaching was terminated at 48 hours. Gold recoveries from the P₈₀ 150 microns and finer feeds ranged between 97.6 and 98.5%. The 75- and 105-micron samples leached very quickly, with extraction almost complete in 24 hours, slightly slower for the 150 micron sample. Two additional bottle rolls with 0.5 g/l NaCN at P₈₀ 150 and 105 microns recovered 97.3 and 98.3% respectively. Overall, the samples were insensitive to grind size or reagent strength.

Cyanide consumption was very low, less than 0.07 kg/t of ore for the three coarser samples and 0.16 kg/t of ore for the 75-micron sample. Lime consumption in all tests was 0.5 kg/t. Calculated gold head grades averaged 1.33 g/t which agrees very well with the metallic screen assay discussed above.

13.3.6 GRG Gravity Concentration

Standard GRG testing was carried out in triplicate on three 10 kg sub samples. Three sequential liberation/concentration stages were tested at P₈₀ 850, 250 and 75 microns. Overall recoveries ranged between 80.8 and 88.0%. A fourth, extended, ("EGRG") test which includes a more detailed evaluation of product particle sizes for use in plant circuit modelling recovered 88.8%. Gravity recoveries increased linearly with increasing head grade

13.3.7 Bulk Gravity Concentration

A single bulk gravity rougher concentration test was conducted on 47 kg of composite 4160-001 (all remaining sample) to produce concentrate and tailing for further testing. Feed size was P₈₀ 75 microns, gold recovery was 73.3% into 0.93% weight with grade of 93.48 g/t (back-calculated from subsequent cyanide testing). Gravity rougher tailings grade by direct assay was 0.32 g/t.

13.3.8 Cyanidation of Gravity Concentration Products

Rougher concentrate was subjected to cyanide leaching with 5 g/l NaCN and resulted in recovery of 98.9% after 24 hours. A split sent to Gekko Laboratories in Australia for testing with their proprietary system (basically much higher cyanide concentration) returned 99% recovery after 24 hours.

Pre-Feasibility Study

A split of rougher tailings was leached with 1 g/l NaCN and resulted in 96.2% recovery after 24 hours

13.3.9 Flotation

Flotation was tested on the bulk gravity tailings generated from composite 4160-001 at P₈₀ 75 microns. Grade of the tailings tested was 0.26 g/t. Rougher flotation produced a concentrate containing 73.7% of gold in the tailings in a mass pull of 3.5%. On this basis combined recovery (gravity and flotation) would produce a concentrate containing 94.1% of the gold contained in the whole ore assaying 24 g/t in 4.4% by weight.

Flotation was also tested on residual material from the comminution composite (4160-002) ground to P₈₀ 75 microns. Grade of the material tested was 0.64 g/T. Since this had no preconcentration treatment it was effectively “whole ore”, a related, but different, composite compared to 4160-001. The material responded reasonably well, the resultant concentrate recovered 83.2% of the gold into 2.6% by weight with a grade of 20.36 g/T.

The range in flotation recoveries requires additional testing to evaluate the impact of gravity preconcentration, grade, reagent regime, grind size and flotation kinetics that were not investigated in this program due to sample availability, schedule and budgetary constraints.

13.3.10 Cyanidation of Flotation Products

The flotation concentrate from 4160-002 was subjected to cyanide leaching with both 1 and 5 g/l NaCN, with ultimate recoveries of 94 and 98.9% respectively after 48 hours.

13.4 Phase Two Testwork, TriStar

A second phase of metallurgical testing was conducted on three drill core composites representing gold bearing material from Esperança South.

The work was carried out at McClelland Laboratories Inc. Their report, MLI job No. 4490, dated March 30, 2020, describing test methods, protocols and results may be summarized as follows.

Drill core from 14 drillholes were already in-house at MLI. Three composites were prepared to represent low grade (4416-002), life-of-mine (4416-001) and high grade (4416-003) material from the project. Head grades predicted for the respective composites, based on interval assays, were 0.55 (LG), 1.06 (LOM) and 4.06 (HG) g/t Au ore. Free gold, up to about 0.5 mm in size, was observed in gravity concentrates produced from all three composites.

Processing options evaluated for each composite included “whole ore” agitated leach; gravity concentration with gravity tails leach; and gravity concentration with gravity tails flotation and concentrate leach. Leaching of combined gravity and flotation concentrate was also tested for the LG composite.

All three composites were amenable to “whole ore” milling/cyanidation. Tests were conducted at 80% - 150 microns in size, using a 1.0 g NaCN/l cyanide concentration. Gold recoveries ranged between 94.1

Pre-Feasibility Study

and 98.2% and leach rates were rapid, though gold extraction was progressing at a slow rate when leaching was terminated at 48 hours.

All three composites responded well to gravity concentration at an 80%-150 microns feed size. Gold recoveries reporting to the gravity rougher concentrates (<1% of feed weight) increased with increasing feed grade and were equivalent to between 37% and 69% of the total gold. Combined gold recoveries obtained by gravity concentration and gravity tailings cyanidation were roughly equivalent to those obtained by whole ore leach. Gold recovery rates were more rapid when the gravity concentrate was removed before leaching.

Gravity tailings (recombined cleaner and rougher tails) from each composite were also used for flotation testing, with cyanidation of the flotation concentrate. Final tail grades for these tests (0.10 - 0.34 g/t Au) were somewhat higher than those obtained by whole ore leach or gravity tailings leach (0.3 – 0.07 g/t Au), probably because the gravity cleaner tailings were included in the flotation feed. It is believed inclusion of the gravity cleaner tailings in the flotation feed may have led to particulate gold losses to the flotation tailings. The flotation concentrates generated from the gravity tailings were readily amenable to agitated cyanidation treatment. Combined (gravity/flotation/concentrate leach) gold recoveries increased with feed grades and ranged from 66.2% to 90.1%. It is believed that inclusion of the gravity cleaner tailings with the leach feed would result in higher overall gold recoveries.

A single test series was also conducted on the low-grade composite, at an 80% - 150 microns feed size, to evaluate rougher gravity concentration followed by rougher flotation, with regrind and agitated cyanide leaching of the combined (gravity and flotation) rougher concentrate. This test was conducted in part to confirm that the flotation tailings grade could be decreased by removing a larger mass (rougher) gravity concentrate before flotation. Results showed that the low grade composite responded well to this processing sequence. The combined (gravity/flotation) concentrate leach recovery was equivalent to 80.8% of the gold contained in the "whole ore". The flotation rougher tail grade (0.05 g/t Au) obtained after removing a gravity rougher concentrate was incrementally lower than that obtained (0.08 g/t Au, avg.) when gravity cleaner tailings were included in the flotation test feed but fell within the range of tail grades obtained during those tests (0.04 - 0.12 g/t Au). It is expected that removing the gravity cleaner tailings from the flotation feed would have a more pronounced effect (higher gold recovery), for higher grade feeds.

Additional "whole ore" agitated cyanidation testing was conducted on the low grade (LG) composite to evaluate sensitivity to grind size (80%-250 microns to 80%-105 microns). Results showed that gold recovery increased from 83.9% at an 80%-250 microns feed size to 94.1% at an 80%-150 microns feed size. Grinding finer (80%-105 microns) did not further improve gold recovery. Comparative leach tests were conducted at the 150 microns feed size, on all three composites using a cyanide concentration of 0.5 gNaCN/l. Gold recoveries were essentially the same as for feeds leached using 1.0 gNaCN/l. The LG composite was also tested at the three other feed sizes using the lower (0.5 gNaCN/l) cyanide concentration. Gold recoveries varied somewhat with cyanide concentration, but the variations are believed to fall with experimental and analytical precision limits.

Pre-Feasibility Study

Reagent consumptions were low. Cyanide consumption for the “whole ore” leaching using 1.0 g/l cyanide were less than 0.2 kg/t ore. Lime consumption was 0.3 kg/t ore. Reagent consumption for flotation concentrate and gravity tailings leaching were lower, on a “whole ore” basis.

Uncrushed, half drill core from holes CSH 11,12,14 and 16 was randomly sampled from top to bottom downhole and submitted to Hazen Research in Golden Colorado for SAG mill testing (in association with JKSimMet, Contract Services in Red Bluff, California) and determination of Bond ball mill grinding and abrasion indices. Results which have been incorporated in TriStar process design and cost estimation are contained in their reports.

All of the material submitted for grinding and abrasion testing at Hazen was returned to MLI for grinding and conditioning before being transferred to Pocock Industrial, Inc. for slurry characterization and solid liquid separation testing. Results which have been incorporated in TriStar process design and cost estimation are contained in their report dated March 2020.

13.5 Phase Three Testwork, TriStar

A third phase of metallurgical testing was conducted on nine RC cuttings composites from Esperança South to compare the response to whole ore milling/cyanidation against gravity concentration, followed by flotation, with agitated cyanidation of the combined (gravity + flotation) concentrates.

The work was carried out at McClelland Laboratories Inc. Their report, MLI job No. 4567, dated August 14, 2020, describing test methods, protocols and results may be summarized as follows.

A total of six individual composites, designated 4567 Recomp One through Six (4567-001 through 4567-006) were prepared for whole ore agitated cyanidation at an 80% - 105 microns feed size, and to generate sample for preparation of three master composites. Master composites were prepared, to represent low grade, medium grade and high grade material types (4567-007, 008 and 009). Each of these master composites was subjected to gravity concentration, at an 80% - 105 microns feed size, to generate a concentrate and gravity tailings. Each gravity tailings sample was subjected to conventional flotation treatment to generate concentrate, which was combined with the corresponding gravity concentrate and subjected to regrind and intensive cyanidation.

Recoveries from the whole ore leach tests ranged between 96.3% and 99.1%, averaging 98%.

All six individual composites were readily amendable to whole ore milling/cyanidation treatment, at an 80% - 105 microns feed size. Gold recovery rates were rapid, and gold extraction was substantially complete in 24 hours. Cyanidation consumption (<0.1 kg/t) and lime consumption (<0.5 kg/t) were very low.

The master composites were amenable to a processing sequence including gravity concentration, followed by flotation of the gravity tailings and agitated cyanidation of the combined (gravity flotation) concentrate, at an 80% - 105 microns feed size. Concentrate cyanidation gold recoveries from the low, medium and high grade master composites were equivalent to 82.7%, 80.1% and 90.2%, respectively, of the gold contained in the whole ore. These recoveries were 8% to 19% lower than the respective whole ore grind/leach.

Pre-Feasibility Study

Cyanide consumptions for concentrate leaching were very low (0.08 kg/t ore) and similar, on a whole ore basis, to those expected for whole ore grind leach. Concentrate leaching lime requirements were lower (0.1 kg/t ore) than whole ore leaching requirements.

Pre-Feasibility Study**14 MINERAL RESOURCE**

For this Pre-Feasibility Study (PFS), TriStar updated the resource block model described in its technical report entitled “Mineral Resource Update for the Castelo de Sonhos Gold Project, Pará State, Brazil”, with an effective date of December 31, 2020, which was filed on SEDAR on April 30, 2021. This new resource block model takes into account the additional drilling done in 2021, from the beginning of the January through the end of May. The methodology used for estimating gold grades is the same as the one used in the previous resource estimate; multiple indicator kriging was used to estimate the tonnage and grade of selective mining units with grades above the resource reporting cut-off of 0.26 g/t. The domains used for resource estimation were based on a 3D model of litho-geochemical units developed by GoldSpot Discoveries using machine learning, using all drillhole data available by May 2021. The block model was classified into Indicated and Inferred regions using conditional simulation which, as discussed below, improves on the methods used to classify previous resource block models for CDS. All previous models have been classified using metrics from the block-by-block estimation, all of which relate to the configuration of the nearby drillhole data used in the estimate. The use of conditional simulation allows the classification to consider local grade variability and to specifically quantify the uncertainty on gold content in annual production increments.

As with previous resource estimates for CDS, separate resource block models have been created for each of the three main deposit sub-areas; these are shown in blue in Figure 14-1. Mapping, surface sampling and drilling have confirmed that there is resource potential outside the areas outlined in blue, where the soil anomaly is less pronounced because the sedimentary layers are close to vertical. In 2021, TriStar began drilling these other areas and may, in future, extend the areal footprint of resource estimates. For the moment, however, with the immediate need being for accurate resource estimates in areas that are considered in this PFS, the resource block models cover only the areas outlined in blue in Figure 14-1.

Pre-Feasibility Study

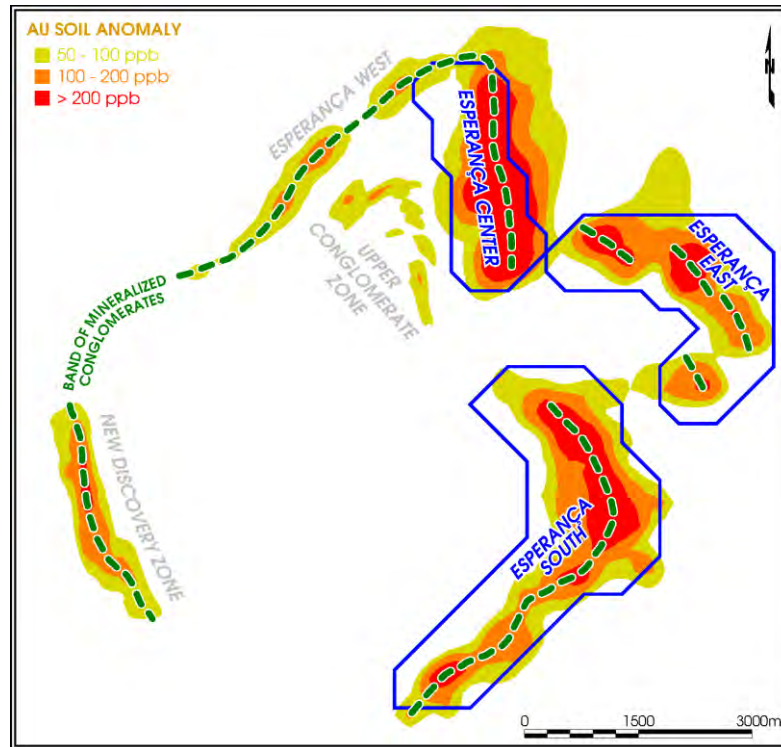

Figure 14-1 The deposit sub-areas (in blue) covered by the current resource estimate.

14.1 Database

14.1.1 Coordinate System

All the work on this updated resource block model was done in SIRGAS-2000 (“SIRGAS”) coordinates that are now the federal cartographic standard in Brazil. All previous resource studies were done in SAD69 (“SAD”) coordinates. Whenever SAD coordinates needed to be converted to SIRGAS, this conversion was either done in software that included tools for coordinate transformations, such as the MX Deposit database management system, or the ProGrid converter provided by the Brazilian federal government, or done using the following formulas:

- $Easting_{SIRGAS} = Easting_{SAD} - 53.96$
- $Northing_{SIRGAS} = Northing_{SAD} - 40.24$

These simple linear transformations have an accuracy of $\pm 0.1m$ anywhere on the plateau but are less accurate as one moves away from the plateau.

14.1.2 Drillhole database

The drillhole database for the Castelo de Sonhos Project is managed using Seequent’s commercial software database management system, MX Deposit, which integrates information from field studies, drillhole logging, location surveys and laboratory assay reports.

Pre-Feasibility Study**14.1.3 Collars**

The drillhole collars used for this updated block model are those for which assays were available at the end of May 2021. At that time, assays were available for all reverse circulation holes up through RC-2020-594 and for all diamond drillholes up through CSH-20-572. The additional drillhole data that was not available at the time of the previous resource estimate includes 11 new diamond drillholes and 44 new reverse circulation holes, most of which are in-fill holes designed to increase confidence in local estimates of resource tonnage and grade.

The two Barrick holes that TriStar was able to survey in 2011, CSDH-13 and CSDH-2A, were assigned SIRGAS collars by converting the TriStar survey of their SAD coordinates. For all the other Barrick holes, whose collars were irretrievably lost when garimpeiros mined in those areas, their original Barrick coordinates were adjusted by the average of the differences seen in CSDH-13 and CSDH-2A (+12m for the Easting and +1.5m for the Northing) to create an estimate of the proper SAD coordinates. With their SAD coordinates either surveyed or calculated by making a small adjustment to the original Barrick data, the SIRGAS collars of the Barrick holes were calculated using MX Deposit.

14.1.4 Down-hole surveys

The down-hole survey database is essentially the same as the 2018 version, which had down-hole survey measurements for the inclined core holes drilled that year. For all holes drilled since 2018, both RC and diamond drillholes, the database records the as-planned orientation at the collar and copies this at the bottom of the hole, causing the trajectory to follow a straight line from the collar, at the planned azimuth and dip. Although this is not ideal, the errors are small because most holes are now RC holes drilled vertically; there are only a few inclined core holes that have been drilled in recent years. The ones that are relevant to resource estimates target the top 120m. Over this length, an error of 1-2° in the collar orientation would result in an error of <4m horizontally at the bottom of the hole, and <1m vertically. Even with the possibility of some droop in the inclined holes, there is very little chance that the bottom sample of the hole is off by more than half the resource block size. This was confirmed by taking all the inclined holes that had down-hole surveys, calculating the proper location of the bottom of the hole using the measurements of down-hole azimuth and dip, and then recalculating the location that would be erroneously calculated if the only available information was a single collar survey, rounded to the nearest 5° for both azimuth and dip. In the 34 inclined holes where this check could be done, the actual location of the bottom of the hole and the location incorrectly calculated from the as-planned collar orientation alone never differed by more than half of the resource block size. The same check, done for vertical holes that have down-hole surveys, confirms that vertical holes do not wander more than half a block at a depth of 150m.

The assumed vertical trajectory of holes drilled at -90° was further checked, where possible, using the azimuth and inclination measurements acquired by the optical televiewer (OTV) tool. In holes that were logged by OTV, the position of the bottom of the hole calculated from the meter-by-meter OTV measurements of hole orientation was within ±2m of the location calculated from the assumption that the hole was truly vertical.

Pre-Feasibility Study

14.1.5 Assays

Exports of assay data from the MX Deposit database include the values to be used for resource modelling; this calculation follows the hierarchy that has been used since 2017 when Leachwell assays first became available (Figure 14-2):

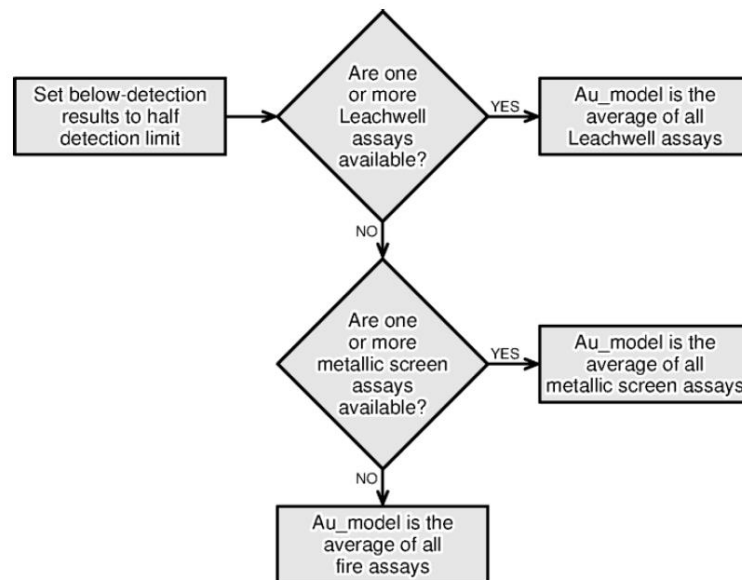

Figure 14-2 Assay selection hierarchy criteria at Castelo de Sonhos.

When considering the possibility of multiple assays for the same sample interval, the MX Deposit database recognizes that additional assays might be reported as:

- check assays were done by the lab when the grade obtained with the first assay warranted a check
- as duplicate assays requested by TriStar, either as part of the regular assay protocol or in separate batches of additional duplicate assays
- as blind replicates created by the preparation lab for the lab's internal QA/QC program
- as duplicates required within each batch by the lab's internal QA/QC program

From the Fall of 2019 through the Spring of 2020, the assay protocol used fire assays to determine which intervals needed the large-volume, more expensive Leachwell analysis. For any interval where the fire assay came back above 0.1 g/t, a second fire assay was done. Once the significant intervals were identified, these were submitted for Leachwell analysis, along with two additional samples, one on either side of each significant interval band.

In the Fall of 2020, and through May 2021, TriStar ceased doing the second fire assay, and just used the first as a screening tool to figure out where Leachwell assays were needed.

Pre-Feasibility Study**14.1.6 Topography**

The XYZ files from Geosolid's LIDAR survey were used to create a 5x5 m topography grid for each of the three project areas: Esperança South, Esperança Center and Esperança East. In each area, the topography grid extends far enough in all directions to span the crest of a reporting pit shell that might go as deep as 150 m below the ground surface, with walls sloping at 55°.

Details of the topography grid for part of Esperança South are shown in Figure 14-3. The Geosolid LIDAR survey has very high precision, on the order of $\pm 0.1\text{m}$ and easily picks out the garimpos. Figure 14-3 shows an example of this, with the air photo at the top and the topography contour map at the bottom. Since the topography shows the "super-trenches" dug by the garimpeiros, the resource block model does not treat the voids of the garimpos as a rock.

Pre-Feasibility Study

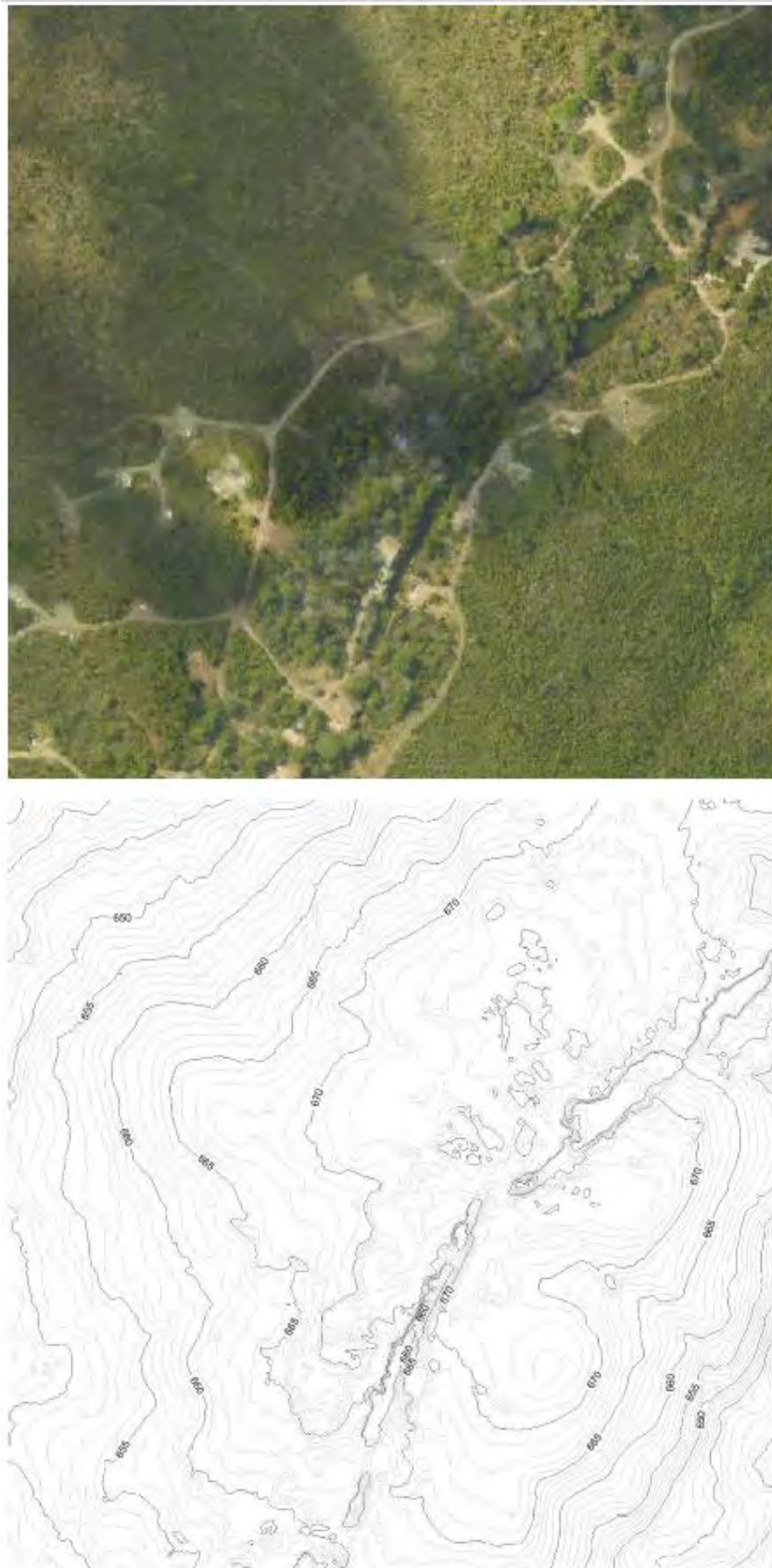

Figure 14-3 An example of the LIDAR topography's ability to identify surface depressions of garimpos.

Pre-Feasibility Study

14.1.7 Density

The density database is the same as the one available in 2018: the 28 drill core samples of the conglomeratic horizon that had an average dry bulk density of 2.68 t/m³. This is very similar to the densities used for resource estimates at Tarkwa and Jacobina, the two closest analogs of CDS, and slightly lower than values in technical papers for the density of strongly silicified and hematized quartzites.

14.2 Modelling of Local Bedding Orientation

The triangles of the litho-geochemical wireframes developed by GoldSpot (Section 9) were used to locally interpolate the direction of bedding for each resource block. Triangles were not used in this interpolation if they were coincident with an erosional surface that formed the top of a unit, if they were coincident with topography, or if they were part of the wireframe of one of the non-sedimentary units. Figure 14-4 shows an example of the grid of local bedding orientations for the A-A' cross-section in Figure 9-6 in the Exploration section.

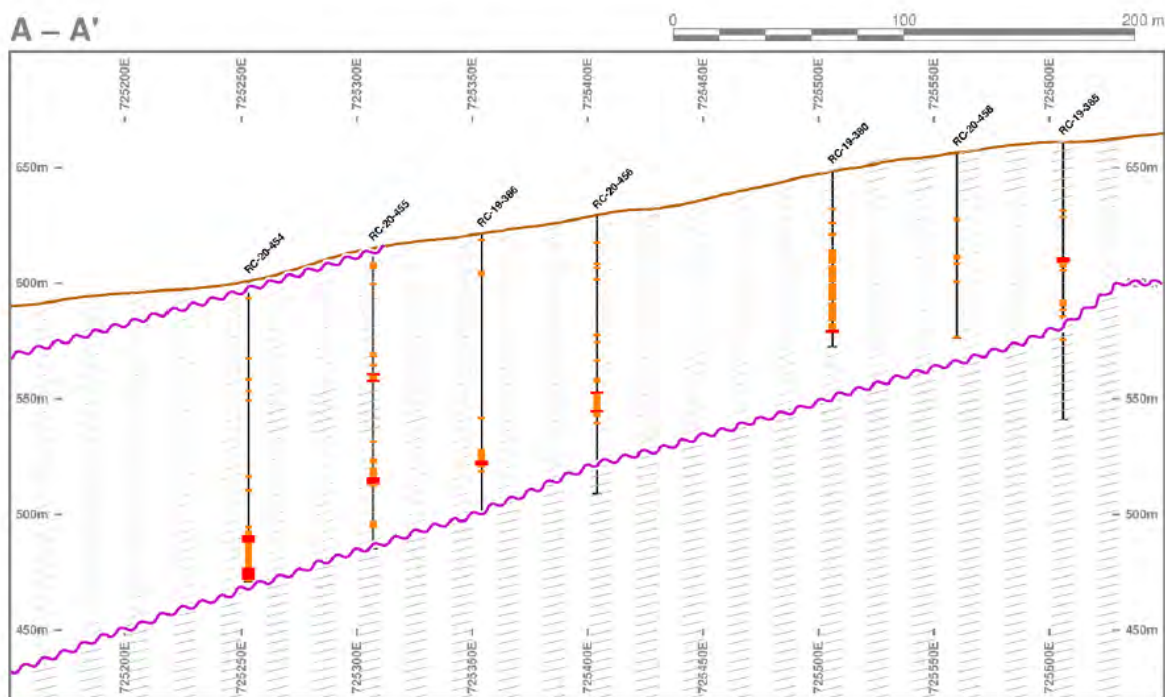

Figure 14-4 Local bedding orientations modelled from bases and non-erosional tops of litho-geochemical units on the A-A' cross-section shown in Figure 9-6.

14.3 Data Analysis and Interpretation

14.3.1 Erosional surfaces

Seven erosional surfaces were identified by GoldSpot and provided as triangulated surfaces in DXF files. For the purposes of this study, these have been assigned numbers, from ES #1 for the oldest (deepest) to ES #7 for the youngest (shallowest). Table 14-1 shows the numbers used in this report and the names of the original DXF files provided by GoldSpot.

Pre-Feasibility Study

Table 14-1 Numbers and file names for erosional surfaces.

ES#	GoldSpot's DXF file name
1	Geological Model - 02_Erosional_LowK&Th_Bottom.dxf
2	Geological Model - 05_A_Erosional_High_K_Bottom.dxf
3	Geological Model - 06_A_High_Th_Bottom.dxf
4	Geological Model - 20_Ferrous Sediment_Clean_Si_bottom.dxf
5	Geological Model - 50_Aluminous Sediment_bottom.dxf
6	Geological Model - 70_Erosional High_K_contact.dxf
7	Geological Model - 90_Erosional High_Th_bottom.dxf

14.3.1.1 Esperança South

In Esperança South, the ES#4 and ES#5 unconformities partition the conglomeratic band into three erosional packages. Figure 14-5 shows side-by-side boxplots of the gold assay distribution in each of these packages. The grades in the middle package tend to be higher than in the other two: more than 50% higher, on average. The differences between the grade distributions support the view that the packages should be treated as separate domains for the purposes of grade interpolation. The decision to treat them as separate domains is also consistent with these packages being separated by erosional surfaces; whatever spatial continuity may exist within the sedimentary rocks, it is very likely to be disrupted across stratigraphic unconformities.

The differences seen in the grades of the three packages, with the middle package having the highest grades, are consistent with observations made by TriStar's external consulting geologists, both of whom have expressed the view that the strongest gold mineralization occurs in the cobble conglomerates that lie near the middle of the conglomeratic band (Lipson, 2016; Karpeta and Lipson, 2019).

Pre-Feasibility Study

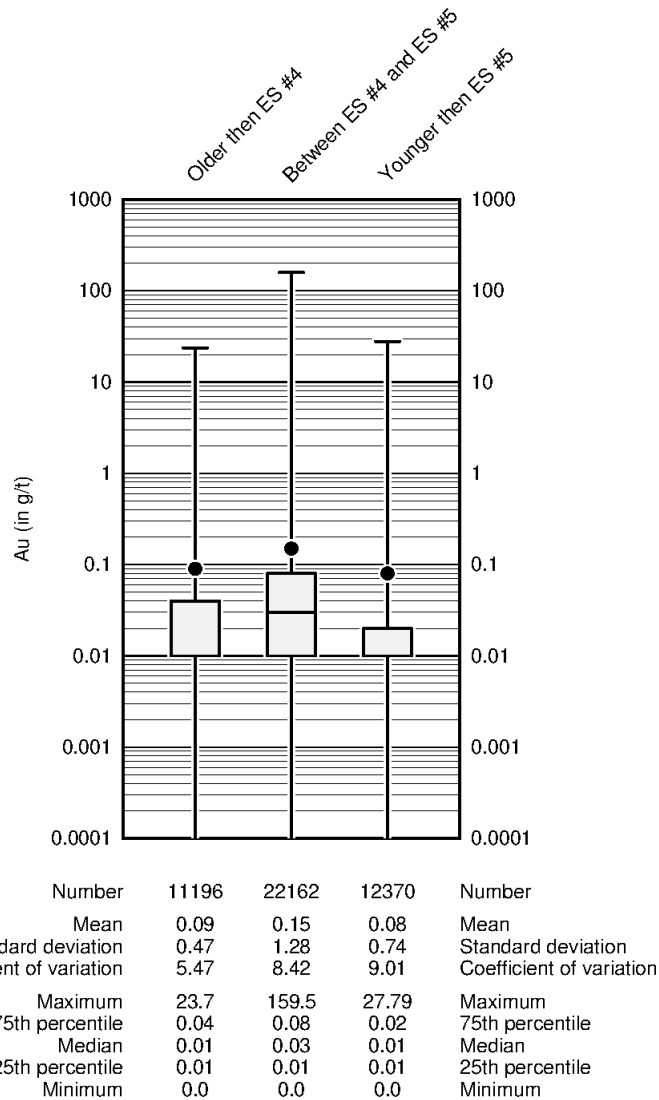

Figure 14-5 Boxplots of gold assays in Esperança South for the three erosional packages separated by the unconformities.

14.3.1.2 Esperança Center

Three of the erosional surfaces that GoldSpot interpreted across the plateau cross the Esperança Center area. Although the Esperança Center resource block model could have been separated into three erosional units, almost all the drillhole assays in this area fall between the same two erosional surfaces that were used as domain boundaries in Esperança South, ES#4 and ES#5. Since MIK needs several hundred samples to estimate grade distributions, all of Esperança Center was treated as belonging to the same erosional unit. Figure 14-6 shows a comparison of the assay grades in Esperança Center to those in the middle erosional unit of Esperança South. The average gold grade is the same in both areas, which indicates that the GoldSpot interpretations of erosional surfaces are sound; but there is less total variability in Esperança Center than in Esperança South. This is understood to be the result of Esperança South having been more distal at the time of deposition, where the winnowing action of near-shore processes segregated the gold into thinner, higher-grade bands that were separated by wide intervals with very low grades.

Pre-Feasibility Study

The difference seen in the variability of gold grades has implications on resources and reserves. Although Esperança South has a higher average grade above the resource reporting cut-off, Esperança Center has a higher proportion of resource-grade material. If rising gold prices cause the resource cut-off grade to be lowered, the growth in resource tonnage will be greater in Esperança Center. The variability differences also entail that the effect of mining dilution will be less severe in Esperança Center than in Esperança South.

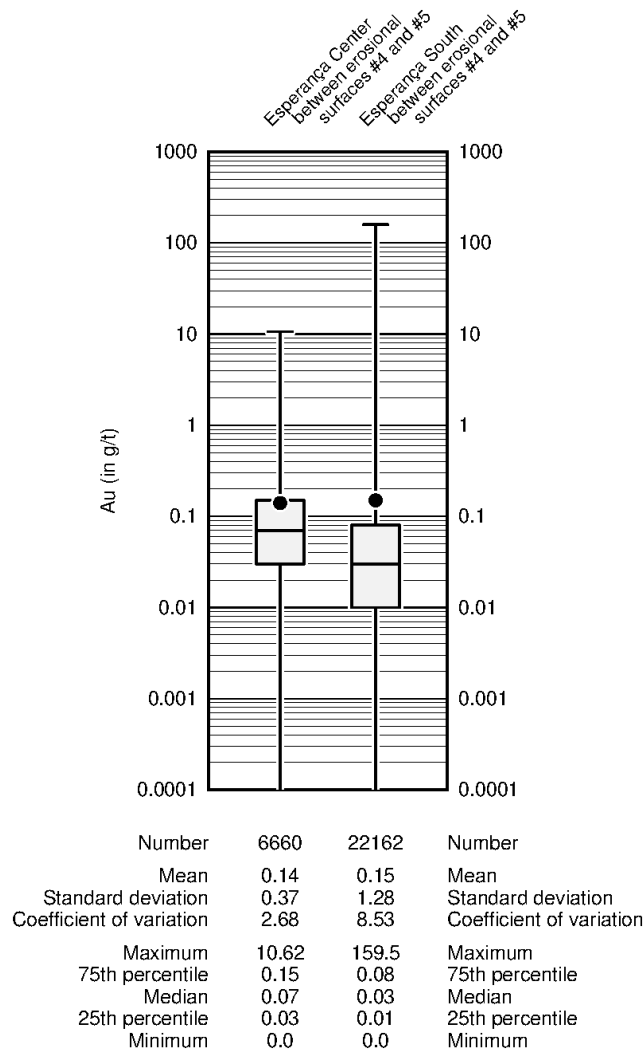

Figure 14-6 Boxplots of gold assays that lie between the fourth and fifth erosional surfaces, in Esperança Center and Esperança South.

14.3.1.3 Esperança East

There are only two erosional surfaces that impinge on Esperança East. As with Esperança Center, almost all the assays in Esperança East are in one erosional package, the sediments that lie between the two oldest erosional surfaces interpreted by GoldSpot. The Esperança East resource estimates treated all the assays as belonging to the same erosional package even though there are a few that fall below ES #1 or above ES #2.

Pre-Feasibility Study

14.3.2 Surface enrichment layer

There is no oxide or saprolitic layer on the Castelo de Sonhos plateau; many drillholes do, however, show higher gold grades near the ground surface. The existence of surface enrichment is consistent with the historical presence of small-scale artisanal mining. Studies of artisanal mines elsewhere indicate that manual mining is attractive to small-scale miners if gold grades are well above 2 g/t; the 1–2 g/t average grades seen at depth in the reefs at Castelo de Sonhos would likely not have supported the many large super-trenches created by garimpeiros.

The base of this domain was modeled directly from picks of the base of the continuous high-grade band at the top of holes that showed surface enrichment. At holes where no surface enrichment was evident, the thickness of the surface-enrichment layer was modeled as zero, causing the base of this layer to be coincident with the ground surface.

Figure 14-7 shows the footprint of the surface-enrichment layer in Esperança South, which ranges in thickness from 0 to 10 m, averaging 2.3 m where it exists. The average grade in the surface enrichment layer in Esperança South is almost 8x the average grade in the layer immediately below.

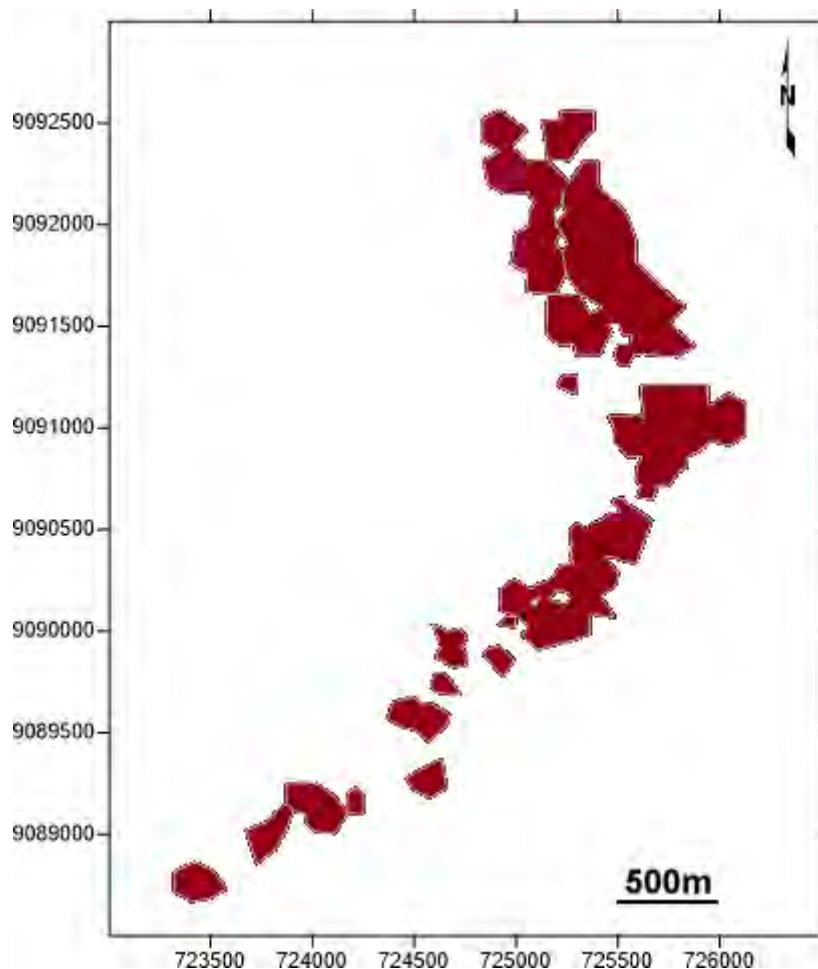

Figure 14-7 Map view of the areal extent of the thin surface enrichment layer in Esperança South.

Pre-Feasibility Study

Figure 14-8 shows the footprint of the surface-enrichment layer in Esperança Center, which ranges in thickness from 0 to 9 m, averaging 2.7 m where it exists. The average grade in the surface enrichment layer in Esperança Center is almost 4x the average grade in the layer immediately below.

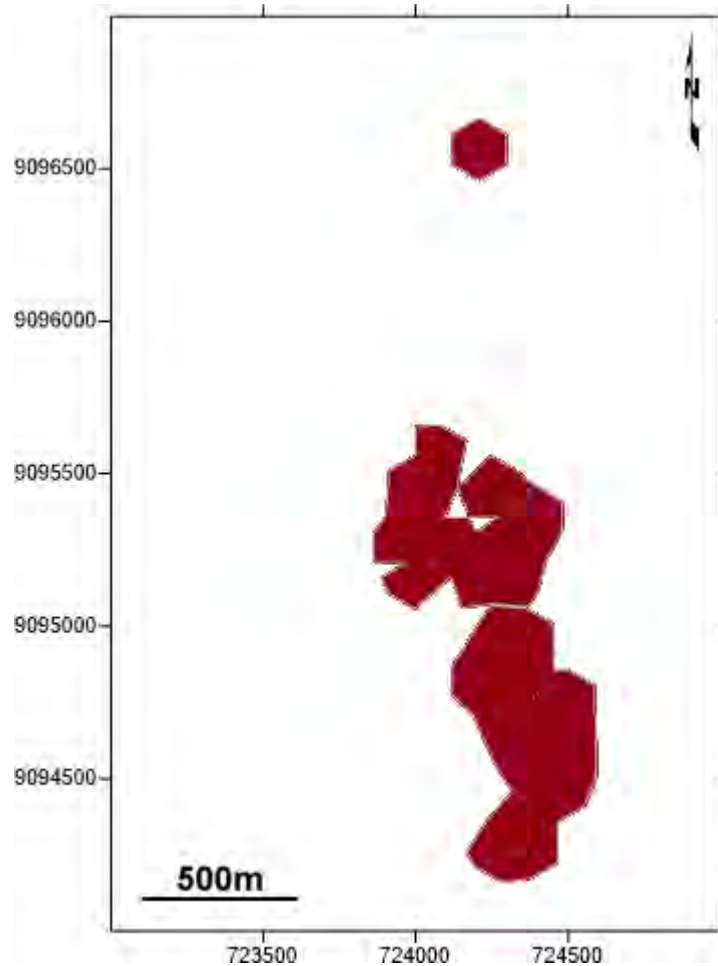

Figure 14-8 Map view of the areal extent of the thin surface enrichment layer in Esperança Center.

Figure 14-9 shows the footprint of the surface-enrichment layer in Esperança East, which ranges in thickness from 0 to 9 m, averaging 2.3 m where it exists. The average grade in the surface enrichment layer in Esperança Center is almost 8x the average grade in the layer immediately below.

Pre-Feasibility Study

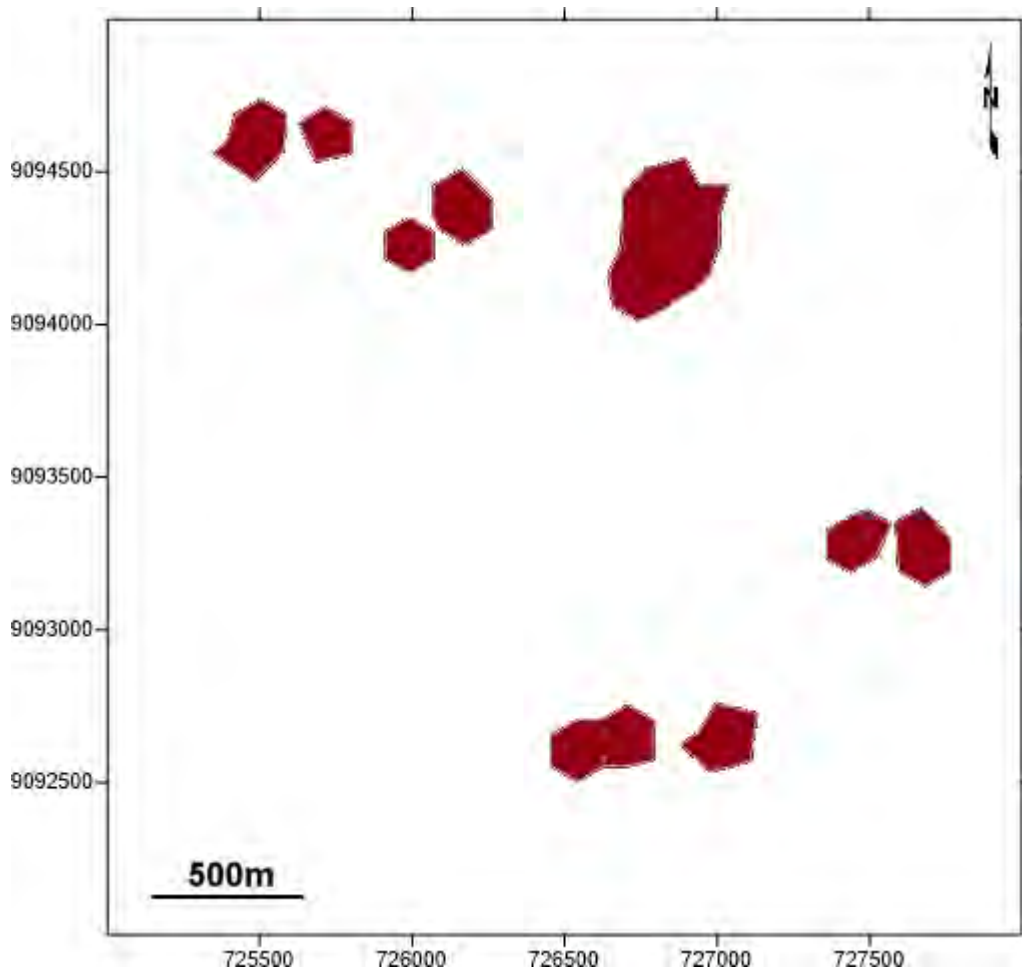

Figure 14-9 Map view of the areal extent of the thin surface enrichment layer in Esperança East.

Throughout the resource block model areas, the surface-enrichment layer is thin: 2–3 meters where it exists, and often completely absent in many holes. It therefore accounts for very little tonnage in the resource block models. Its importance in grade estimation is that it ensures that high-grade samples near the surface are not inappropriately smeared down-dip. Since the base of the surface-enrichment layer serves as a hard boundary, high gold grades near the surface cannot be extrapolated below the base of this layer.

14.3.3 Litho-geochemical units

In the May 2021 update of the litho-geochemical model, GoldSpot identified 13 units with distinct multi-element chemistry. These were grouped into three sets:

- i) The units that have higher-than-average gold grades. These include: GoldSpot’s high potassium unit; their lower sandstone unit; their quartz-sandstone and iron-sandstone units; and their phyllite unit. These units generally have higher-than-average iron content and are referred to as the “ferrous sediments” in the text that follows.

Pre-Feasibility Study

- ii) The units that have lower-than-average gold grades. These include: the three units that are distinguished by varying levels potassium and thorium together; the high thorium unit; GoldSpot's upper sandstone unit; the granites and the granitic sediments. These units generally have lower-than-average iron content and are referred to as the "non-ferrous sediments" in the text that follows.
- iii) The mafic dyke units.

Figure 14-10 shows side-by-side boxplots of the gold assay distributions in the three litho-geochemical groups in Esperança South, along with the distribution in the surface-enrichment layer. The average grade in the non-ferrous sediments is half of what is seen in the ferrous sediments. This is likely a reflection of an observation that has often been made about the conglomeratic band at Castelo de Sonhos: that strong gold mineralization often seems to be associated with hematization.

The mafic dyke units are not barren, even though they post-date the paleo-placer gold mineralization by hundreds of millions of years. Intrusive events, and their associated dykes, have remobilized the paleo-placer gold on the Castelo de Sonhos plateau. Both mafic dykes and granitic dykes often have strong gold mineralization at their contact with the surrounding sediments. Because the definition of the mafic unit in the machine-learning analysis of clustering is based on chemistry, and not on visual observations, it is quite possible that the mafic cluster incorporates some of what a geologist would log as meta-sediments. Fluids from the dyke would have permeated the adjacent sedimentary rocks, modifying their multi-element chemistry fingerprints and making them appear more similar to the dyke than to sedimentary rocks further away from the dyke. Although the average grade of the mafic dykes is like the ferrous sediments, the coefficient of variation is very high in the mafic group, a reflection of the fact that this unit contains a mixture of a lot of barren samples and a few samples with very high gold grades.

The surface-enrichment layer has the highest grades but contains few samples.

Pre-Feasibility Study

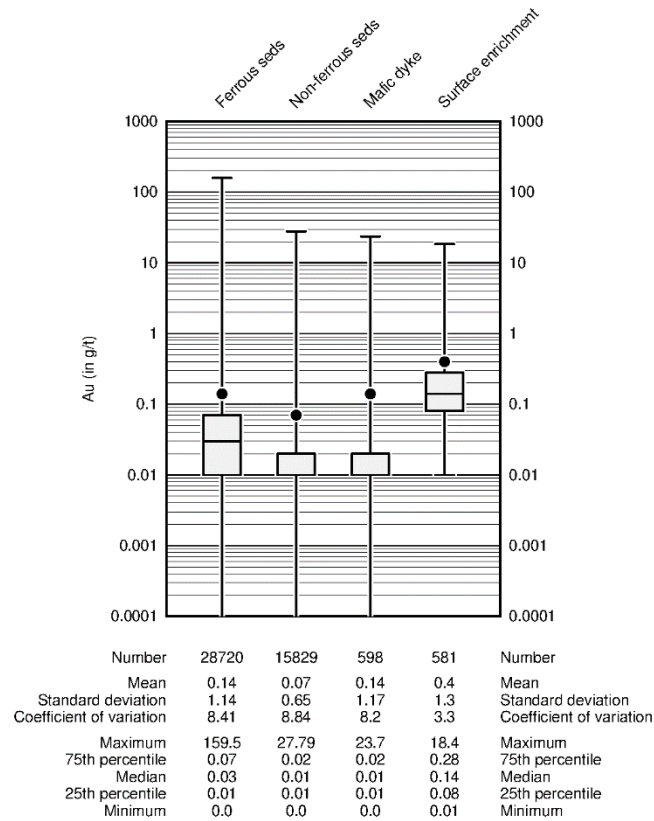

Figure 14-10 Boxplots of gold assay grade distributions in four domains in Esperança South

The assays in Esperança Center show a similar pattern to Esperança South, with the litho-geochemical units identified as ferrous sediments having higher grades, on average, than the non-ferrous sediments. The resource estimates in Esperança Center, therefore, used the same approach to estimation domains as was used for Esperança South: ferrous and non-ferrous sediments are treated as two separate populations beneath a thin layer of near-surface enrichment. The mafic dykes do not cross Esperança Center.

With the Esperança East area sitting beneath older erosional surfaces in the GoldSpot interpretation, the Esperança East conglomerates fall within different litho-geochemical units than those generally seen in Esperança South and Center. In the cluster analysis, Esperança East assays fell in clusters differentiated by their potassium and thorium content, and not in the ones differentiated by their iron content. Although the gold grades are higher in the unit associated with the high-thorium cluster, there are very few samples in this unit (<10), which makes it difficult to be confident that this is a meaningful difference and makes it impossible to treat this unit as a separate domain in MIK. With only one erosional package in Esperança East, no ability to separate meaningful litho-geochemical populations, and no mafic dykes, the MIK in Esperança East was done using only two domains: the thin layer of near-surface enrichment above a single domain of meta-sediments.

Pre-Feasibility Study

14.3.4 Variograms

Experimental variograms of the ferrous units are all similar, in both Esperança South and Center, regardless of where they lie relative to the unconformities, so these were combined into one group for variogram analysis. Similarly, the non-ferrous units were also combined into one group since their variograms are similar above, below and between the two major unconformities. The reason why the unconformities do not seem to play a role in variogram analysis may be an indication that the spatial continuity in the Gilbert fan-delta system is not affected by major marine transgressions and regressions. When deposition resumes after an erosional event, the size, shape and length of sedimentary lobes and alluvial channels is the same as it was before the erosional event. A different explanation for the same observation is that the primary controls on grade continuity may be near-shore marine processes: longshore drift and tidal action. These too are not likely to be affected by transgressions or regressions, which simply change the location of the shoreline, not the mechanics of the processes that occur near it.

The grade interpolation for resource estimation used multiple indicator kriging, with the same variogram model being used for all indicator thresholds, an approach often referred to as “median” indicator kriging (Goovaerts, 1997). Figure 14-11 through Figure 14-14 show the median indicator variograms in Esperança South for each of the domains: ferrous, non-ferrous, mafic, and surface enrichment. The variograms of the two sedimentary groups are similar, with the non-ferrous sediments having slightly shorter ranges than the ferrous sediments in both the bedding direction and the perpendicular-to-bedding direction. The variograms for the mafic dykes have the shortest ranges, but also a slightly lower nugget effect, suggesting that the very short-scale continuity of the remobilized gold might be better than that of the paleo-placer gold. The variograms for the surface enrichment layer show strong horizontal continuity.

The parameters for the median indicator variograms in each group are summarized in Table 14-2.

Table 14-2 Parameters for median indicator variogram models.

	Nugget	1 st exponential structure			2 nd exponential structure		
		C ₁	Rmax ₁	Rmin ₁	C ₂	Rmax ₂	Rmin ₂
Ferrous	0.45	0.20	25	25	0.35	200	25
Non-ferrous	0.45	0.20	20	20	0.35	160	20
Mafic	0.30	0.30	15	15	0.40	120	15
Surface enrichment	0.30	0.35	10	10	0.35	150	10

The long range is in the bedding plane for the sedimentary units, in the average dip of the dykes for the mafic units and horizontal for the surface-enrichment layer. The short-range is perpendicular to the dip plane: across the bedding, across the dyke, or vertical.

Pre-Feasibility Study

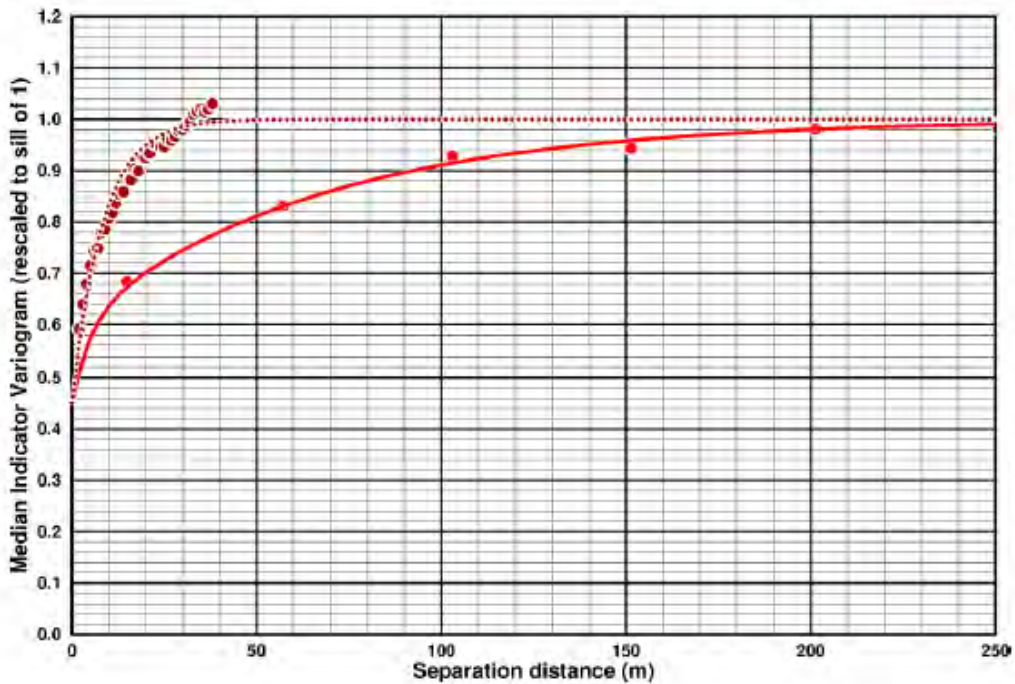

Figure 14-11 Median indicator variography for ferrous sediments, with the solid red line showing the omnidirectional variogram in the bedding plane and the dotted dark red line showing the variogram perpendicular to bedding.

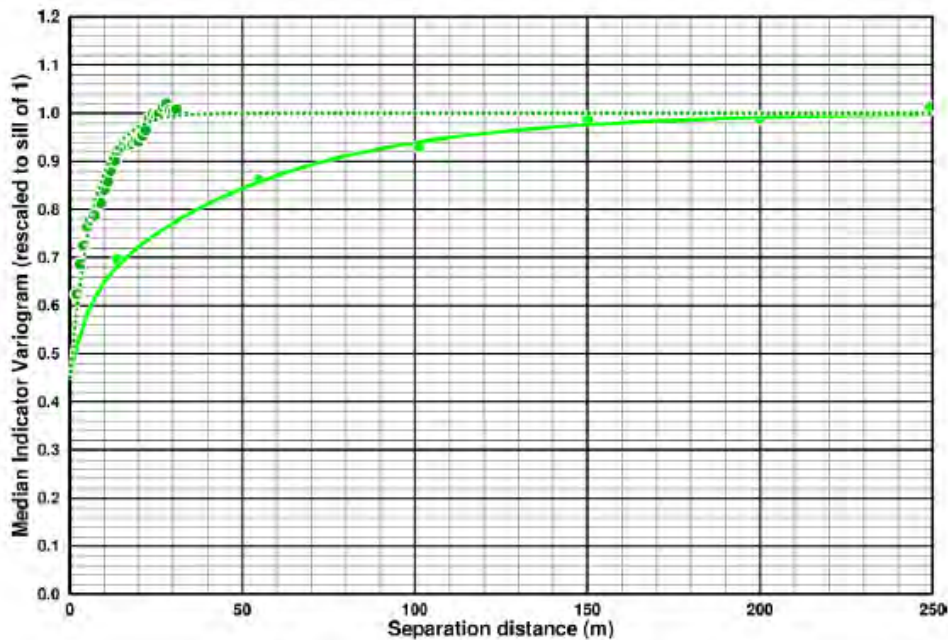

Figure 14-12 Median indicator variography for non-ferrous sediments, with the solid green line showing the omnidirectional variogram in the bedding plane and the dotted dark green line showing the variogram perpendicular to bedding.

Pre-Feasibility Study

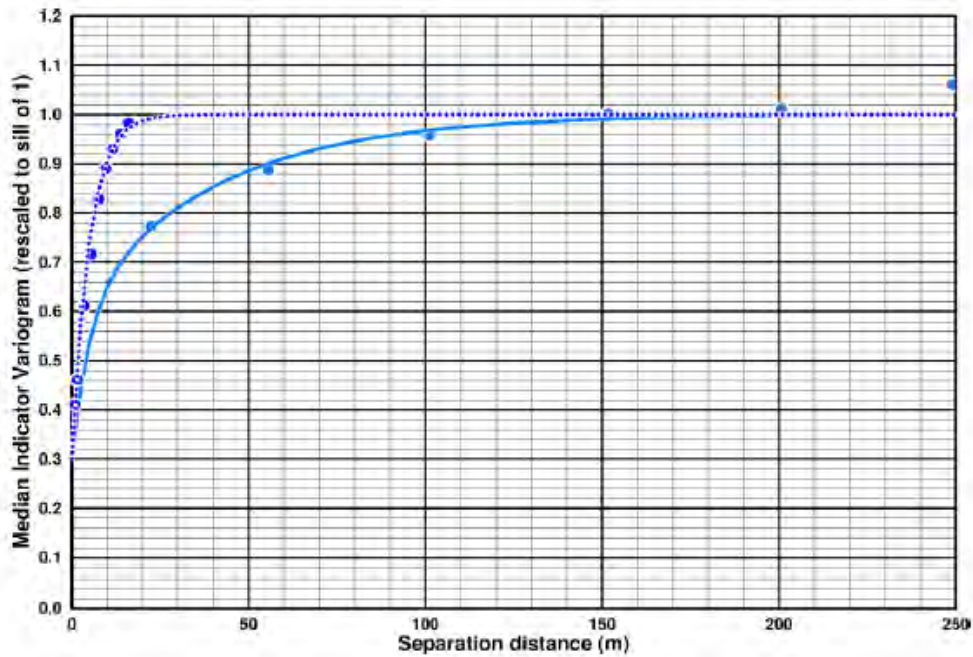

Figure 14-13 Median indicator variography for the mafic dykes, with the solid blue line showing the omnidirectional variogram in the average dip plane of the dykes and the dotted darker blue line showing the variogram perpendicular to the dykes.

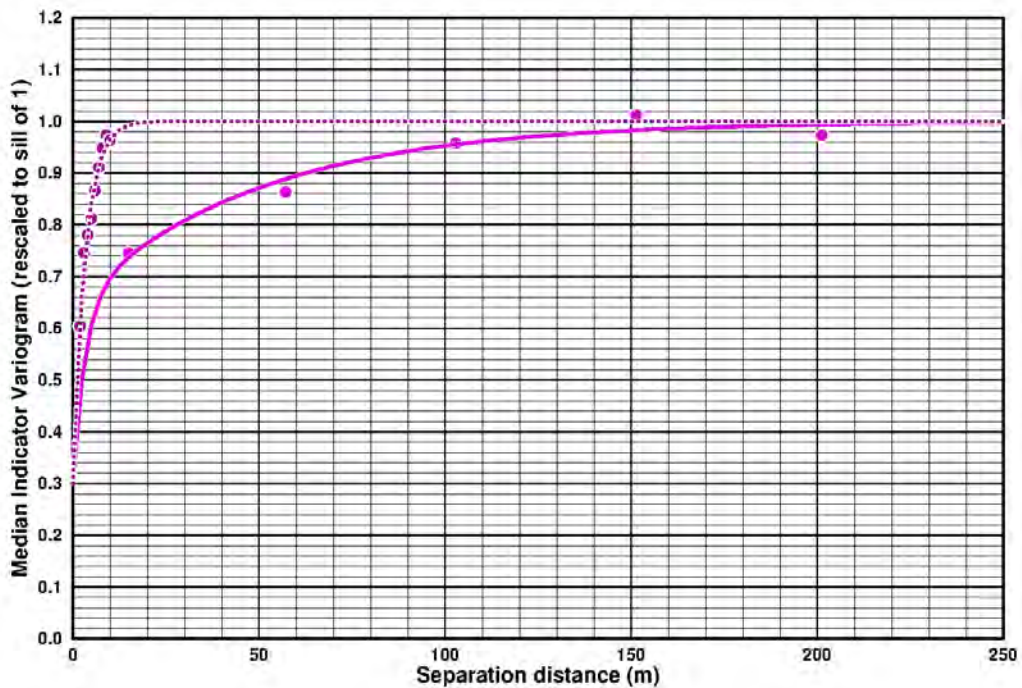

Figure 14-14 Median indicator variography for the surface enrichment layer, with the solid light purple line showing the omnidirectional variogram in the horizontal direction and the dotted darker purple line showing the variogram in the vertical direction.

The ranges of correlation are slightly longer than those seen in previous studies of Castelo de Sonhos. This is likely due to the use of a much more locally detailed geological model that not only separates

Pre-Feasibility Study

data into different domains but also allows the calculation of directions of maximum continuity to be much better localized. Although previous studies have used a broad model of the shape of the conglomeratic band to guide predictions of bedding orientation, none of the previous studies have had the wealth of local detail that comes from the cluster analysis of geochemistry and the integration of this with surface geophysics to create a plausible and a data-consistent 3D model of the stratigraphic architecture of the plateau.

The experimental variograms in Esperança Center are similar (but noisier, due to fewer data pairs) to those shown in Figure 14-11, Figure 14-12 and Figure 14-14 for Esperança South. The variogram models used for the ferrous, non-ferrous, and surface-enrichment domains in Esperança Center were the same as those used for Esperança South (Table 14-2).

In Esperança East, where the ferrous and non-ferrous clusters do not occur, the experimental variograms are like those of the non-ferrous sediments in Esperança South: generally lower in grade, and with shorter ranges of correlation than the ferrous sediments. The non-ferrous variogram model shown in Table 14-2 was used as the variogram model for the single sedimentary domain in Esperança East; and the surface-enrichment variogram model shown in Table 14-2 was used for the corresponding domain in Esperança East.

14.4 Domains for Resource Modelling

The three sedimentary packages created by the two major unconformities, combined with the groupings shown in Figure 14-10 create eight domains for estimation in Esperança South: three ferrous domains separated by the two unconformities; three non-ferrous domains separated by the two unconformities; one mafic domain that cuts across the unconformities; and the surface-enrichment domain.

The contacts between these have been treated as “hard” boundaries even though a conventional analysis of continuity across the boundaries does not show any sudden discontinuity in gold grade across any erosional surface or litho-geochemical boundary. The decision to treat the eight domains as separate populations for grade interpolation rests on the fact that their grade distributions, or their ranges of correlation are different, or there is geologic reason to believe that spatial continuity is interrupted at erosional unconformities.

The ferrous sediments predominate in the middle package, between the two unconformities. This interpretation, derived solely from machine learning analysis of multi-element geochemistry clusters, is consistent with observations made by TriStar’s external consulting geologists, both of whom have noted that hematization is not pervasive throughout the conglomeratic band but occurs predominantly in the center of the band in the unit they have identified as the “cobble conglomerate”, and immediately above and below that cobble conglomerate (Lipson, 2016).

The fact that hydrothermal fluids carrying iron from granitic intrusions were more easily able to find their way into the middle of the conglomeratic band is consistent with the cobble conglomerate being more porous than the finer-grained units toward the base and the top of the conglomeratic band. Furthermore, the existence of a coarser-grained cobble conglomerate in the middle of the conglomeratic band is consistent with a major marine regression that would have moved the shoreline outward, allowing

Pre-Feasibility Study

coarser sediments to accumulate, followed by a major transgression that would have moved the shoreline inward. The bracketing of the ferrous sediments by major erosional surfaces above and below is therefore consistent not only with specific geological observations of the cobble conglomerate at Castelo de Sonhos and the pervasive hematization around the cobble conglomerate, but also with the geological understanding of how changes in sea level provide Gilbert fan-delta systems with their large-scale stratigraphic architecture.

There are three estimation domains in Esperança Center: the ferrous sediments and the non-ferrous sediments, both within the same erosional package, and the surface-enrichment layer.

In Esperança East there are only two estimation domains: the thin surface-enrichment layer and the underlying meta-sediments.

14.5 Estimation Method

14.5.1 Recoverable resources within large blocks

Most of the previous resource estimates for Castelo de Sonhos have used 5×5×2 m blocks. While continuing to use the same small blocks does have some value when it comes to comparing new models to old ones, there are many better reasons to move to a larger block size as the project enters its feasibility study stage.

A 5×5×2 m block is tiny compared to the drillhole spacing, which is currently 50×50 m, or wider. Grade interpolation into blocks that are much smaller than the drillhole spacing creates a false sense of smoothness in the block model. The similarity between grade estimates of neighbouring blocks is not a reflection of actual grade continuity in the deposit; instead, it is an artifact of small blocks with wide drillhole spacing. The configuration of nearby data barely changes when one goes from one 5×5×2 m block to its neighbour. With the nearby data being the same and in just about the same configuration, the grade estimates of adjacent blocks will end up being very similar in a small-block block model.

Pre-Feasibility Study

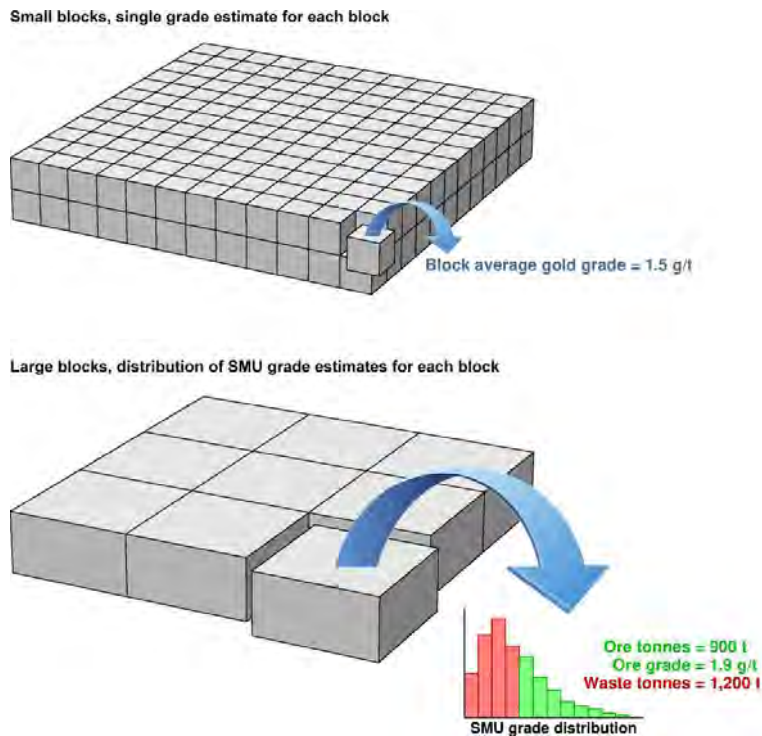

Figure 14-15 Schematic showing the difference between a conventional single-estimate block model and a recoverable-resources block model that provides an estimate of the SMU grade distributions within large blocks.

The temptation to use small blocks owes a lot to the tradition of estimating only the average grade of each block and then treating each block as either being entirely waste or entirely mineralized material, based on whether the estimate of average grade is above or below the cut-off. A different way of tackling resource estimation is to go to bigger blocks and imagine that it will be possible, within each block, to mine some of the material as mineralized while rejecting the rest of the block as waste. As shown in Figure 14-15, this approach estimates a distribution of grades with each block. Drillhole data is used to estimate the grade distribution of samples the size of the drill core, and this distribution is then adjusted to consider the fact that the mine will not be able to segregate mineralized material from waste at the fine-scale of small cylinders of rock but will, instead, have to deal with a practical lower limit on the volume of material that can be segregated and treated separately as either mineralized material or waste. In the technical language of mineral resource estimation, this practical lower limit is usually referred to as the “selective mining unit” (SMU). A block model that aims to estimate, within each block, the grade distribution of SMU-sized volumes is usually referred to as a “recoverable resources” model.

A recoverable resources model does not provide information on exactly where the mineralized material and waste will be found within any single block; the localization of the mineralized material and waste will await definition drilling and, ultimately grade control drilling. The conventional small block / single estimate approach seems to offer a prediction on where exactly the mineralized material and waste lie; but, as noted above, grade estimates for small blocks cannot correctly portray short-scale variability at distances much smaller than the drillhole spacing. Even though each block can be coded as being above or below a cut-off, this is an unreliable basis for mine planning when the blocks are much smaller than the drill spacing.

Pre-Feasibility Study

There are several geostatistical methods for building a recoverable resources model; the most common are the Uniform Conditioning (UC) procedure and Multiple Indicator Kriging (MIK). Done well, by someone experienced in either method, the two give similar results. UC was the method chosen by the QP for the 2017 resource estimates, Adrian Martinez of CSA. The method chosen for this internal resource update is the 'median IK' version of multiple indicator kriging (Goovaerts, 1997). With the median IK approach, the same variogram model is used for all indicator thresholds. This allows one to easily adapt the thresholds to the nearby data values in the search neighbourhood. By setting the indicator thresholds to exactly the specific grade values that occur nearby, the estimated grade distribution ends up being the collection of all nearby data, weighted by the kriging weight given by the median indicator variogram model.

14.5.2 Estimation parameters

14.5.2.1 Block model configuration

In all sub-areas (Figure 14-1) the resource block model uses 20×20×4 m blocks that completely span the deposit sub-area. The horizontal dimension of the blocks is slightly less than half of the 50 m drill spacing. The block height is the same as the bench height chosen for the Preliminary Economic Assessment (PEA) done in 2018.

Table 14-3 shows the boundaries of the block models in each sub-area, and the number of columns, rows and benches. Although the rectangular areas defined by the parameters in Table 14-3 overlap, there is no double-counting of resource blocks because the polygonal outlines shown in blue in Figure 14-1 were used to mask off each sub-area.

Table 14-3 Block model configuration in each sub-area.

		Esperança South	Esperança Center	Esperança East
East-West	<i>Minimum</i>	723000E	723000E	725000E
	<i>Maximum</i>	726500E	725000E	728000E
	<i># of blocks</i>	175	100	150
North-South	<i>Minimum</i>	9088500N	9094000N	9092000N
	<i>Maximum</i>	9093000N	9097000N	9095000N
	<i># of blocks</i>	225	150	150
Vertical	<i>Minimum</i>	146m	336m	108m
	<i>Maximum</i>	674m	632m	536m
	<i># of blocks</i>	132	74	107

Although the height of the block model spans more than 500 m of elevation, the only blocks that get MIK estimates are those within 150 m of the ground surface, the notional depth of an open pit. With similar paleo-placer deposits being mined underground at Jacobina and Tarkwa, there is a possibility that the Castelo de Sonhos plateau could also hold deep resources more than 150 m from the surface that could be developed by underground mining methods. Since the current focus of the CDS Project, however, is the development of a stand-alone open pit mine, no resources have yet been estimated more than 150 m below the ground surface.

14.5.2.2 Volume proportion estimates for domains

In each block, the volumetric contribution of each domain was calculated directly from the litho-geochemical wireframes and the erosional surfaces. Very close to half of the blocks (49%) lie entirely

Pre-Feasibility Study

inside a single domain; the other half have a mixture of two or more domains. The wireframes for the litho-geochemical units have all been clipped to topography, so any volume not accounted for by the rock domains is air.

14.5.2.3 Density

All rock in the resource model is assumed to have a dry bulk density of 2.68 t/m³, the average of the density measurements done on drill core in 2018.

14.5.2.4 Grade distributions

For each domain that contributes to a block, MIK was used to estimate its assay grade distribution from nearby samples within the same domain. In half the blocks, only one MIK estimation is necessary because the block falls entirely within a single domain. In the other half, MIK estimations are needed for each domain, with the grade distribution for each domain being estimated with an entirely different set of nearby samples. In most of the blocks that straddle domain boundaries, two MIK estimations are needed. In rare instances, especially near the mafic dykes, MIK needs to be run three times to estimate the grade distributions in each of the three domains that contribute material to some blocks.

14.5.2.5 Search ellipsoid

A 200×200×25 m search ellipsoid was used for the MIK estimates for every domain in every block. This aligns the search ellipsoid with the variogram model of the ferrous sediments, which had the longest ranges. This entails that the grade distributions for the non-ferrous sediments and the mafic dykes can be estimated from samples slightly beyond the range of their variogram, but this is preferable to not being able to estimate the grade distributions for each domain that contributes to a block in those blocks where there is a mixture of ferrous and non-ferrous sediments or a mixture of ferrous sediments and mafic dykes.

For the ferrous and non-ferrous domains, the long axes of the search ellipse were parallel to the local bedding direction calculated from the litho-geochemical wireframes (e.g., Figure 14-4). For the mafic dykes, the long axes of the search ellipse were parallel to the orientation of the dykes, which have an average strike of N77°W and dip 20° to the south. For the surface-enrichment layer, the long axes of the search ellipse were horizontal, and the short axis was vertical.

14.5.2.6 Octant search and requirement that samples within the same block always be used

Since multiple indicator kriging is an attempt to estimate a distribution, it works best when many nearby samples are used. The search strategy used an octant search and allowed up to four samples in each octant. In blocks that fall entirely within a single domain, the MIK estimates were usually based on 32 nearby samples from that domain. In blocks that straddle domain boundaries, the MIK estimates can be based on 64 nearby samples from two domains or, in rare instances (usually near mafic dykes) on 96 nearby samples from three domains.

It is possible, especially in areas with dense drilling, that some of the nearby samples that were dropped in the octant search (because there were at least four other samples that were closer in the same octant)

Pre-Feasibility Study

still fall within the block being estimated. To ensure that the calculation of the grade distribution in each block always considers the samples that fall within that block, additional samples were included if they fell within the block being estimated but had been dropped during the octant search.

14.5.2.7 Upper-class mean

One of the reasons MIK produces good results on deposits with erratic high grades is that the workflow calls for careful attention to be paid to the upper class. MIK replaces the capping of high-grade values with the choice of a conservative mean value for the upper class. With the median IK approach allowing the thresholds to be adapted to each search neighbourhood, it might appear that there is no reason to worry about the upper class. But the underlying problem of erratic high values having undue influence does not go away. Even when the median IK version is being used, it is still good practice to choose a high threshold and to calculate a conservative value that can be used as the average grade above this threshold.

For all three sub-areas, 5 g/t was chosen as the highest cut-off; this is approximately the 99.5th percentile of the grade distribution. From the assay database, the raw average grade of the assays above 5 g/t is 11.1 g/t. For the interim resource model, the average assumed for any material above 5 g/t was lowered to 10 g/t; this results in a loss of about 3% of the metal content. 10 g/t also happens to be the assay capping value that has been used in previous resource estimation studies, so this MIK model treats erratic high values in a manner similar to what has been done historically for the project.

Below 5 g/t, the indicator thresholds are set to the assay values in the search neighbourhood, so there is no need for class means: each assay value below 5 g/t ends up falling in its own class and can speak for itself.

14.5.2.8 Volume-variance adjustment and SMU size

MIK estimates the grade distribution at the level of selectivity of the drillhole samples small cylinders of rock that are often regarded as “points”. Before the mineralized material and waste tonnages and grades are calculated, the point-grade distribution must be adjusted so that it properly reflects the grades that can be expected for SMU-sized volumes. This adjustment consists of preserving the mean of the point-grade distribution while reducing its variance. For this interim resource update, the method used for the volume-variance adjustment is the indirect lognormal correction (Isaaks and Srivastava, 1989), which needs just one parameter: the variance reduction factor, which calibrates how much less variable the SMU grades will be than the original drillhole grades.

For this interim resource update, the SMU is assumed to be 3.5×3.5×2 m. This assumption is based on the following considerations:

- The size of the SMU is often set to the size of a single truckload since this is the minimum volume of rock that could be sent to the process plant or the waste dumps. 3.5×3.5×2 m contains approximately 65 tonnes of rock, in-situ. The truck size selected in the project’s 2018 PEA was 40t.

Pre-Feasibility Study

- The size of the SMU is sometimes chosen according to the blast hole spacing. At Tarkwa, the operating mine whose deposit is the best analog for Castelo de Sonhos, the blast hole spacing is approximately 3.5 – 4 meters.
- The PEA envisaged a 4m bench height, and many paleo-placer open pits use half-bench mining in daily operations to minimize dilution and mineralized material loss.

There are two ways of estimating how much the variance of the gold grade distribution will decrease going from drillhole assays to 3.5×3.5×2 m blocks: one uses the variogram model to calculate a theoretical value, the other uses composite statistics to calculate an empirical adjustment directly from drillhole data.

Using the variogram models for the sedimentary units (Table 14-2) the theoretical approach gives a variance reduction factor of 46%. Using the assay database, the empirical variance reduction going from assays to 2 m composites is 44%. For the volume-variance adjustment of the MIK point-grade distributions, the variance reduction factor was assumed to be 45%.

Since the ferrous, non-ferrous, and mafic material can be segregated within the pit, based on a combination of visual observation and portable XRF analysis, the volume-variance adjustment was done separately for the ferrous sedimentary rocks, for the non-ferrous sedimentary rocks and the mafic dykes. In each of these groups, the SMU grade distribution moves toward the mean of that group, and not toward the mean of the entire block. This assumption has implications for grade control practices. If day-to-day grade control does not include an attempt to separate ferrous and non-ferrous materials and to keep both separated from dykes, then the mine will experience more dilution than has been assumed in this study.

For blocks that straddle unconformities, the grade distributions from both sides of the unconformity were combined before the volume-variance adjustment was done. This is a slightly pessimistic assumption because it assumes that it will be difficult to recognize unconformities in the pit, and this may not be a correct assumption. It is possible that detailed mapping in the pit might be able to recognize unconformities, and that this might allow the rock to be separated if one side of an unconformity is known to be mineralized while the other side is known to be barren.

14.6 Classification

Resources were classified using conditional simulation to identify regions where the uncertainty on annual gold production is small enough to meet the requirements of the CIM Definition Standard that Indicated Mineral Resources have sufficient confidence “to support mine planning and economic evaluation of the deposit”. Several technical papers (e.g. Rossi and Camacho, 2001; Verly and Parker, 2021) present the view that mine planning and economic evaluation require uncertainties of less than ±15% in the tonnage, grade and metal content of annual production increments.

The classification approach focuses on the in-situ gold content of the material above the reporting cut-off for two reasons:

Pre-Feasibility Study

- Metal content has the highest uncertainty because it is the product of tonnage and grade. If the uncertainty on metal content is less than $\pm 15\%$, then the individual uncertainties on grade and tonnage will also be less than $\pm 15\%$.
- Metal content is directly related to gross revenue.

Accordingly, the approach used for classifying the PFS resource block model aims to identify blocks that are at the center of regions that contain approximately a year's worth of production and where the uncertainty of the estimated annual gold content is less than $\pm 15\%$. This departs from, and improves on, past practice at Castelo de Sonhos, where classification was done block-by-block and then smoothed to remove short-scale noise. The use of conditional simulation to assess uncertainty over large regions removes the short-scale noise seen in classification systems that are based on criteria based on estimation metrics of single blocks. Linking classification to $\pm 15\%$ uncertainty on annual revenue makes the economic assessment presented in this report reliable at the level widely adopted for preliminary feasibility studies.

14.6.1 Conditional simulation

Conditional simulation is a geostatistical method for creating a family of equally likely scenarios of what the in-situ gold grades could look like. Each scenario honors drillhole data and reproduces the histogram (distribution) and variogram (spatial continuity) of the grades. In so doing, conditional simulation can be thought of as the spatial version of the Monte Carlo methods used for quantitative analysis of risk in many engineering fields (Kroese et al., 2014). Conditional simulation has previously been used on the Castelo de Sonhos project, to establish the exploration target range in 2016 (TriStar Gold, 2016).

14.6.2 Procedure for quantifying uncertainty on in situ gold content in annual production increments

For each block in the resource block model, P-field Simulation (Froidevaux, 1992) was used to create 100 versions of gold grade and tonnage above the reporting cut-off (0.26 g/t) within the immediate vicinity of the block, using a flattened ellipsoid with radii of 216m (horizontally) and 27m (vertically). This ellipsoid contains, on average, one year of run-of-mine plant feed and mimics the geometry of open-pit production, spanning several hundred meters horizontally and only a few benches vertically.

Each of the 100 scenarios created by conditional simulation provides its own version of what the in-situ tonnage above the reporting cut-off could be, and what the grade of the tonnes above cut-off could be; the product of these two gives the in-situ gold content of the material that would be delivered to the mill under that scenario. Taken together, the 100 different versions of possible gold content form a probability distribution that provides a quantitative basis for assessing the local uncertainty of both the tonnage and grade of the resource estimate at that location. If the 90% confidence interval of this probability distribution was within $\pm 15\%$ of the resource estimate of the gold contained within the flattened ellipsoid, the block was classified as Indicated; otherwise, it was classified as Inferred.

Figure 14-16 shows two examples of the probability distributions derived from conditional simulation. The block whose local uncertainty is shown in Figure 14-16 is marked as A. At this location, in the well-drilled heart of Esperança South, where drillhole spacing is approximately 50x50 m, uncertainty on annual gold content is less than $\pm 15\%$ and the block is classified as Indicated. The block whose local

Pre-Feasibility Study

uncertainty is shown in Figure 14-17 is marked as B. At this location, near the periphery of current drilling in Esperança South, where drillhole spacing is wider than 100x100 m, uncertainty on annual gold content is greater than $\pm 15\%$ and the block is classified as Inferred. Because MIK estimates were done only for blocks that had abundant data within the range of the variogram, Inferred resource estimates do not extend beyond the distance over which gold grades are spatially correlated.

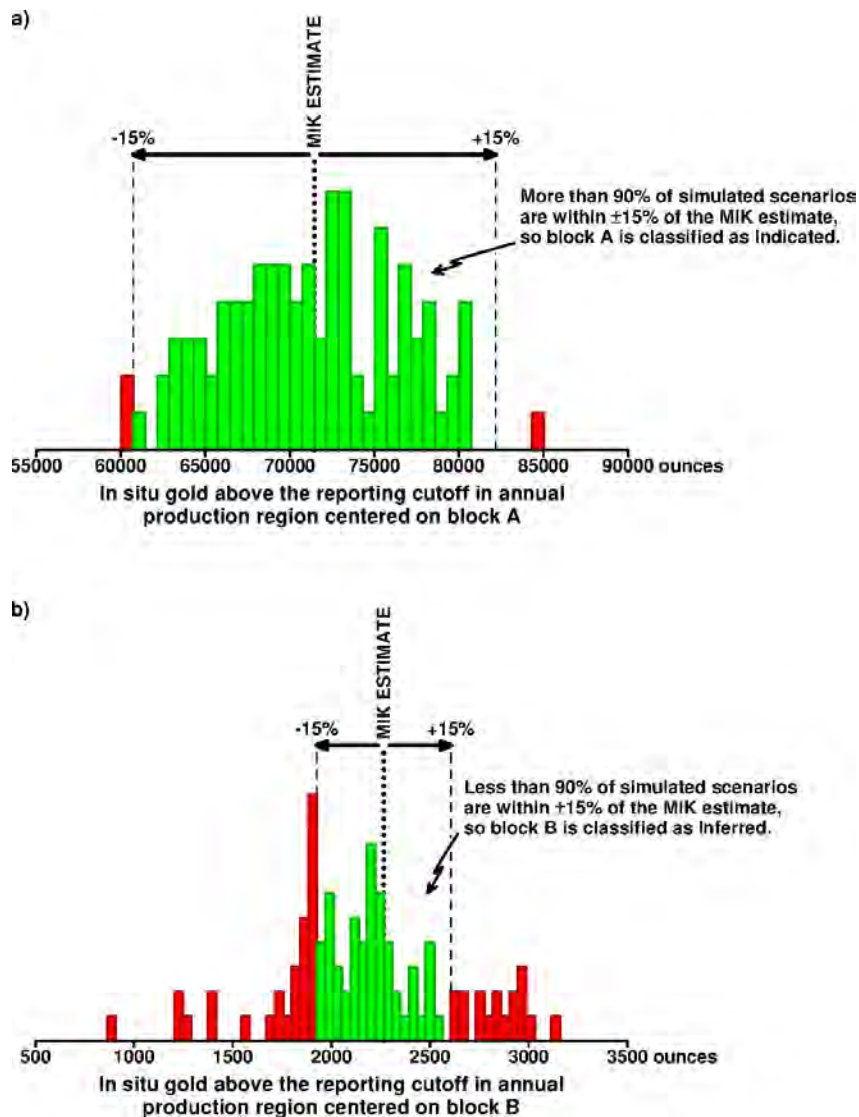

Figure 14-16 Two examples of the local uncertainty in annual gold content, as calculated using conditional simulation. The probability distribution shown in a) is for the block annotated as A on the following figure; the probability distribution shown in b) is for the block annotated as B on the following figure.

Pre-Feasibility Study

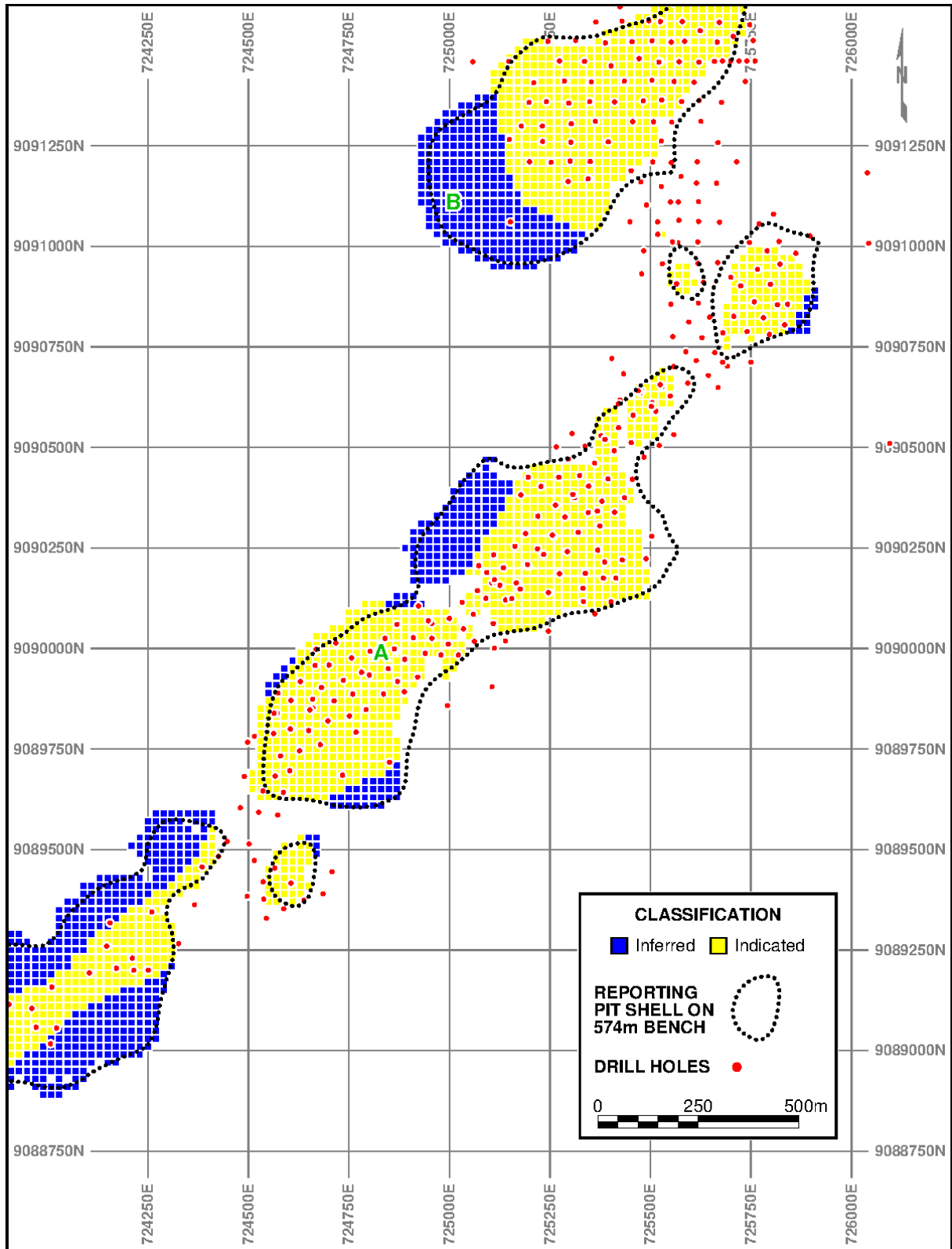

Figure 14-17 Detail of the final classification codes on the 572 – 576 m bench of Esperança South. The green A and B labels mark the locations of the two blocks whose conditional simulation results are shown in the previous figure.

Pre-Feasibility Study

Areas classified as Indicated by conditional simulation will have a combination of two factors that contribute to higher certainty:

- tighter drillhole spacing, typically 50x50m, and/or
- less variability in the gold grades in that region

The classification procedures used in previous resource estimates for Castelo de Sonhos have used information on proximity to nearby samples to classify the confidence in block estimates according to drillhole spacing. The conditional simulation method used in this prefeasibility study improves on previous practice by also incorporating into the classification system information on local grade variability.

Following the classification based on conditional simulation, an open pit shell was used to further constrain resources so that they meet the requirement of having reasonable prospects of economic extraction.

14.7 Reporting Pit Shell

Once the blocks had been classified using conditional simulation, a reporting pit shell was developed using Whittle, using all of the economic and technical parameters that were used to calculate reserves (Section 15), except for the gold price, which was set to a value slightly below the high of the past decade, an intentionally optimistic assumption designed to ensure that the reporting pit shell includes any resources that have reasonable prospects for economic extraction by open pit methods during the coming decade.

14.8 Block Model Validation

The block models created for each sub-area were checked visually against the original drillhole data and the litho-geochemical interpretation, in map view and on cross-sections.

For each 20x20x4 block penetrated by drillholes, its average grade was compared to the average grade of the assays that fall within the block (Figure 14-18). This check assists with the identification of specific blocks where the estimate differs noticeably from the assays inside the block. Examination of the details of several of the estimates that fall well off the main diagonal confirms that the differences are due to the litho-geochemical domains, which can limit the influence of an assay by limiting the volume it can affect, or by other assays outside the block that are nearby and strongly correlated.

Pre-Feasibility Study

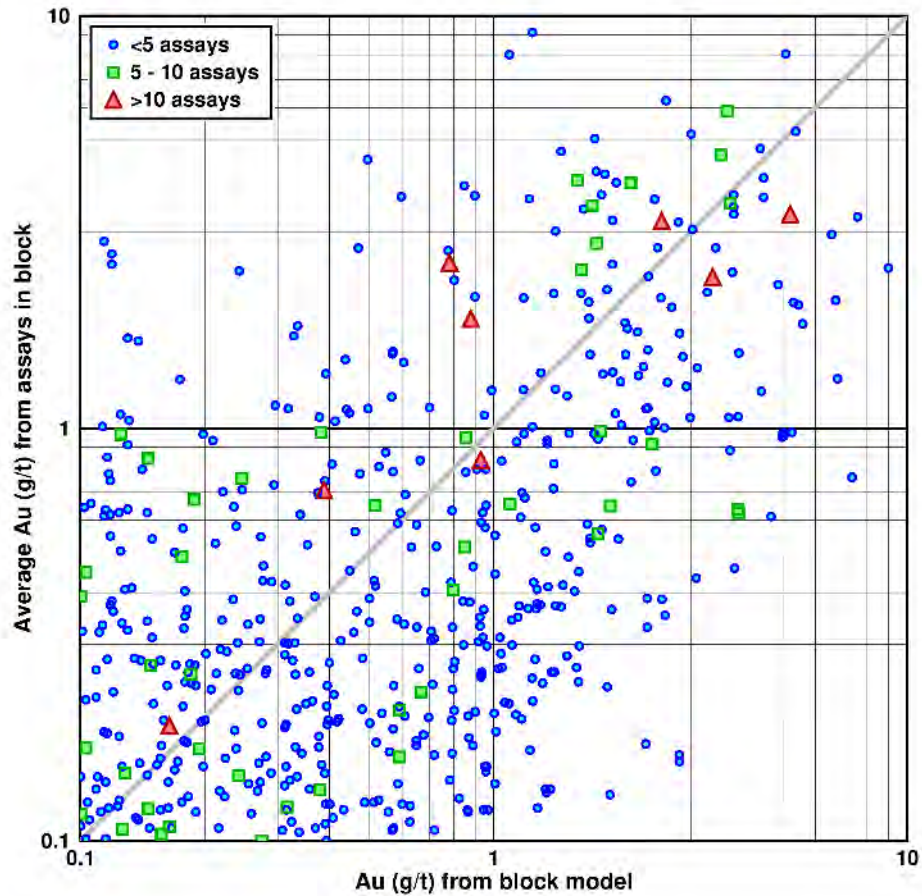

Figure 14-18 Comparison of MIK estimate of block average grade to the average of assays that fall within 20x20x4m blocks in Esperança South, with data colour-coded according to the number of assays in the block.

14.8.1 Validation with independent block model

As a further check on the resource block model developed by TriStar, the QP created another block model using the same database, geological domains and block model dimensions as those used by TriStar Gold but using ordinary kriging instead of MIK to estimate block grades.

Table 14-4 and Table 14-5 show the variogram model parameters and the kriging strategy adopted for the independent ordinary kriging estimation.

Table 14-4 – Variogram model parameters used for independent ordinary kriging block model.

Variable	Variable	Nugget	Dip 1 (°)	Dip Azimuth 1 (°)	Pitch 1 (°)	Structure 1	Sill 1	Range - Major 1 (m)	Range - Semi 1 (m)	Range - Minor 1 (m)	Dip 2 (°)	Dip Azimuth 2 (°)	Pitch 2 (°)	Structure 2	Sill 2	Range - Major 2 (m)	Range - Semi 2 (m)	Range - Minor 2 (m)
ES	Au_Model	0.089	15.6	270	331	Spherical	0.017	97	148	10	16	270	331	Spherical	0.007	195	68	4
EC	Au_Model	0.003	20.0	270	70	Spherical	0.004	100	100	2	20	270	70	Spherical	0.002	120	120	5
EE	Au_Model	0.003	20.0	270	70	Spherical	0.007	120	120	3	20	270	70	Spherical	0.006	120	120	16

Pre-Feasibility Study

Table 14-5 - Kriging search neighborhood parameters for independent ordinary kriging model

Ore body	Pass	Variable	Dip	Azimuth	Pich	Search type	Major (m)	Intermediary (m)	Minor (m)	Min samples	Max samples
ES-EC-EE	1	Au	15	270	330	Ellip	50	50	10	4	8
ES-EC-EE	2	Au	15	270	330	Ellip	100	100	20	4	8
ES-EC-EE	3	Au	15	270	330	Ellip	200	200	40	4	8
ES-EC-EE	4	Au	15	270	330	Ellip	1000	1000	1000	1	8

Figure 14-19 shows the comparison of the estimations made by TriStar (the E-type estimate from MIK) with the estimations made by the QP's ordinary kriging (OK) model for Esperança South. Also shown on this figure are the nearest neighbor (NN) estimate and the calculations done directly from the drillhole composites, both declustered and non-declustered. The corresponding comparisons for Esperança Center and East are shown in Figure 14-23 and Figure 14-30.

Figure 14-19 through Figure 14-30 shows the histograms of the block estimates for the various methods and confirms that the estimates converge to the same average. The other three frames show the swath plots in each principal direction: west-to-east across the columns of the block model, south-to-north across the rows of the block model, and bottom-to-top across the benches of the block model. The swath plots show similar peaks and troughs in the Indicated zone, with the drillhole data and the nearest-neighbour model showing more local variability than the smoother ordinary kriging estimate and the MIK estimate whose variability mimics that of selective mining units. Where the swath plots from different methods are visibly different from one another, little data is presented. Where the drilling is dense, in the Indicated zone, the swath plots show good consistency between the different methods.

14.9QP Opinion

The QP considers the TriStar block model developed using MIK to be acceptable as the basis for estimating Mineral Resources and for subsequent calculations of Mineral Reserves.

Pre-Feasibility Study

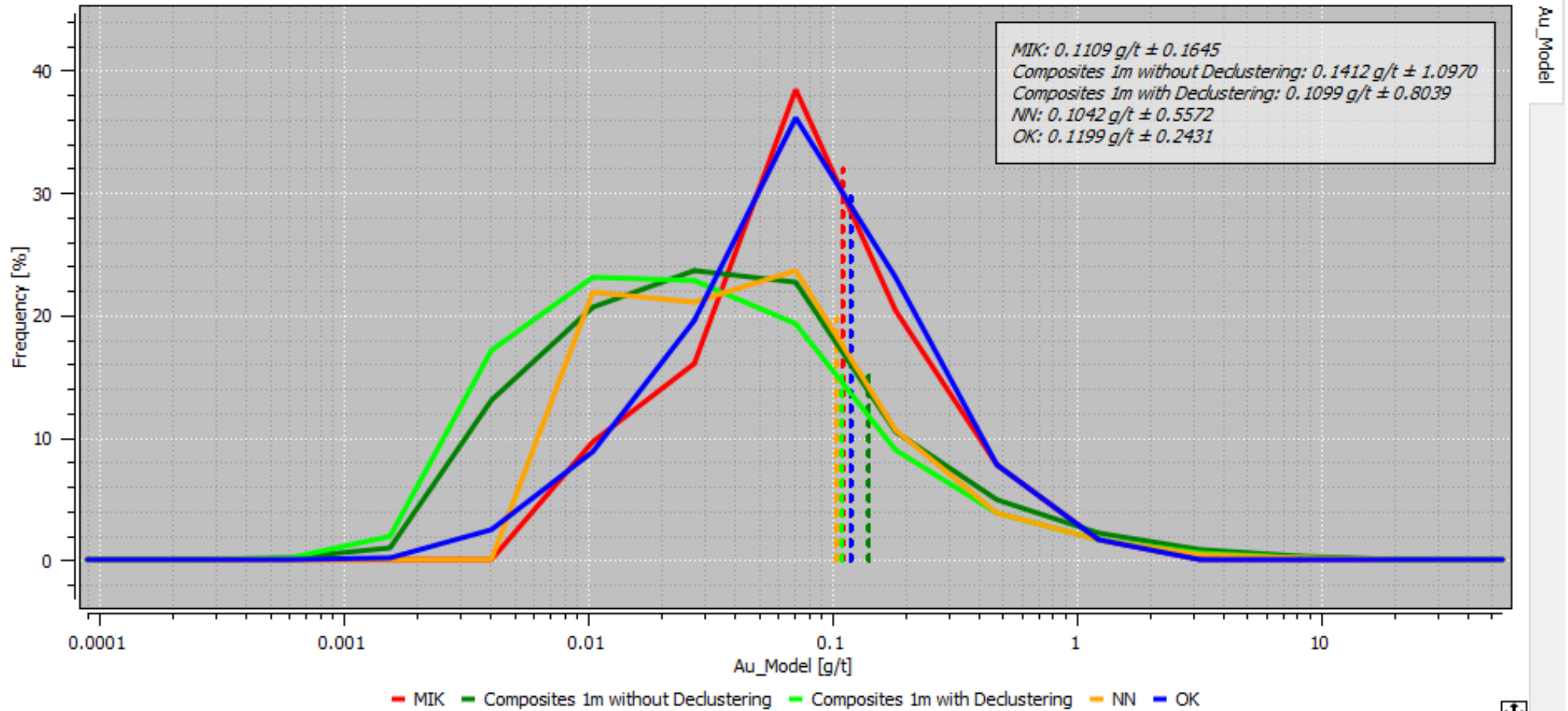

Histogram (MIK – TriStar in red, OK GE21 in blue, NN in yellow, data in green)

Figure 14-19 Resource validation - Esperança South region of Castelo de Sonhos - Histogram (MIK – TriStar in red, OK GE21 in blue, NN in yellow, data in green)

Pre-Feasibility Study

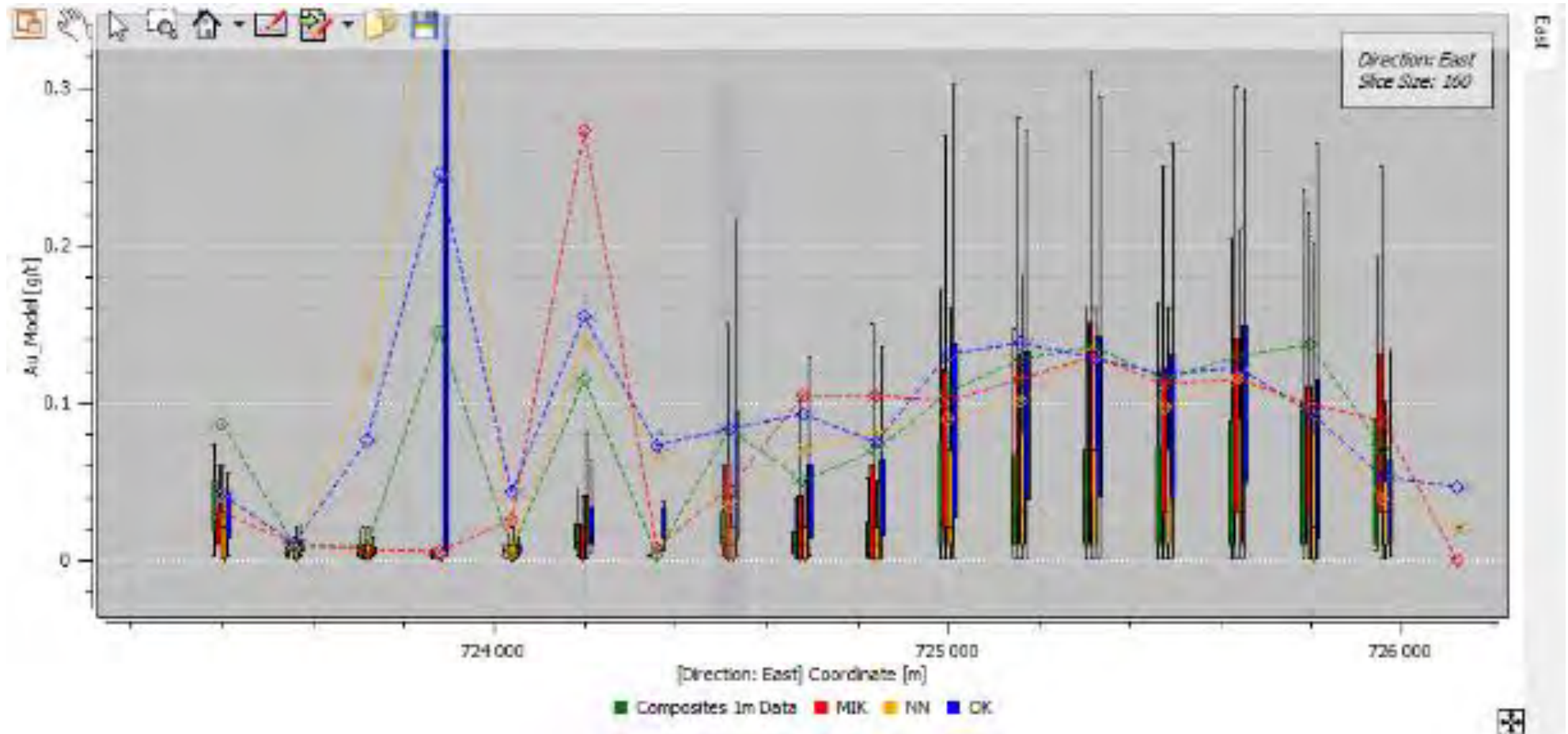

Swath Plot in the east-west direction (MIK – TriStar in red, OK GE21 in blue, NN in yellow, data in green)

Figure 14-20 Resource validation - Esperança South region of Castelo de Sonhos - Histogram (MIK – TriStar in red, OK GE21 in blue, NN in yellow, data in green)

Pre-Feasibility Study

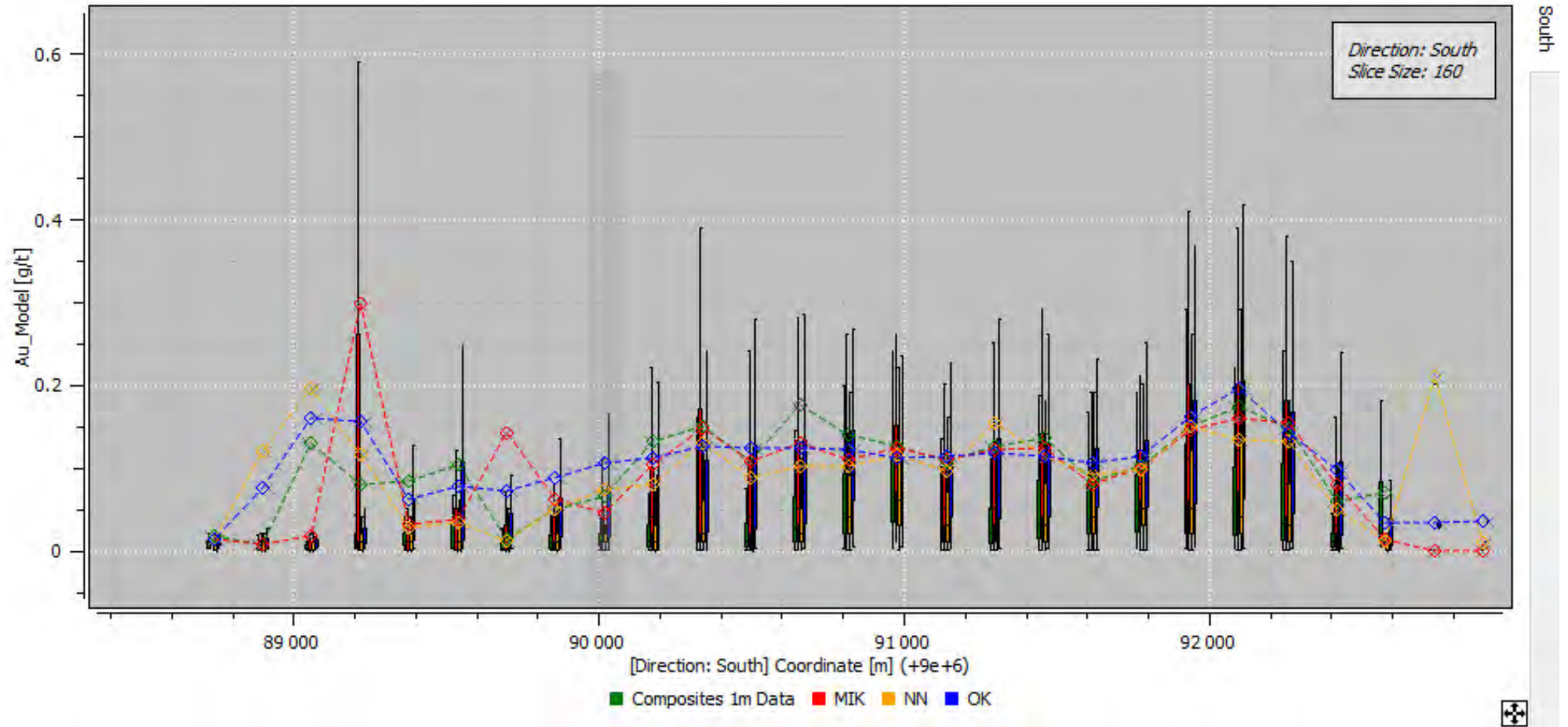

Swath Plot in the north-south direction (MIK – TriStar in red, OK GE21 in blue, NN in yellow, data in green)

Figure 14-21 Resource validation - Esperança South region of Castelo de Sonhos - Histogram (MIK – TriStar in red, OK GE21 in blue, NN in yellow, data in green)

Pre-Feasibility Study

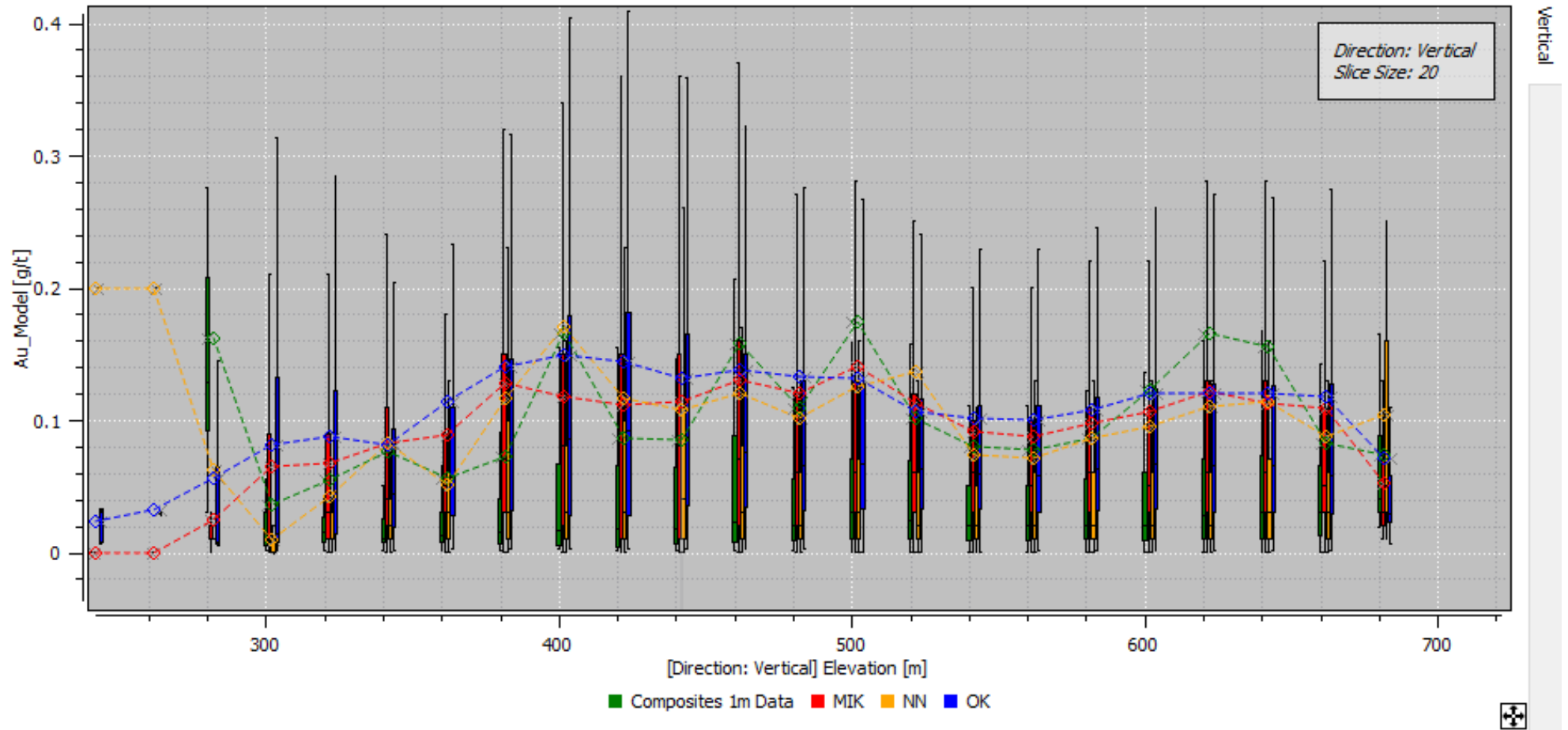

Swath Plot in the vertical direction (MIK – TriStar in red, OK GE21 in blue, NN in yellow, data in green)

Figure 14-22 Resource validation - Esperança South region of Castelo de Sonhos - Histogram (MIK – TriStar in red, OK GE21 in blue, NN in yellow, data in green)

Pre-Feasibility Study

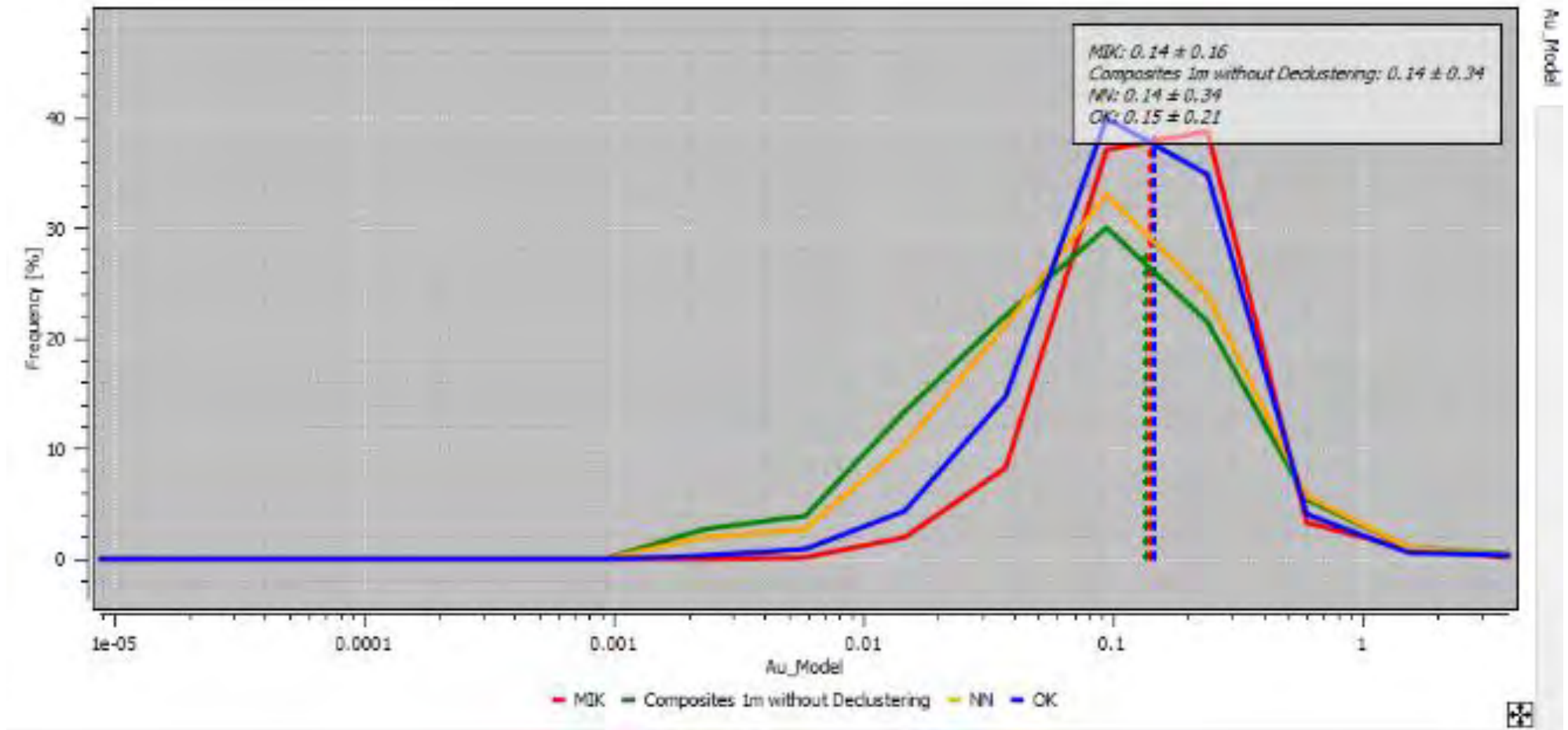

Histogram (MIK – TriStar in red, OK GE21 in blue, NN in yellow, data in green)
Figure 14-23 Resource validation - Esperança Center region of Castelo de Sonhos

Pre-Feasibility Study

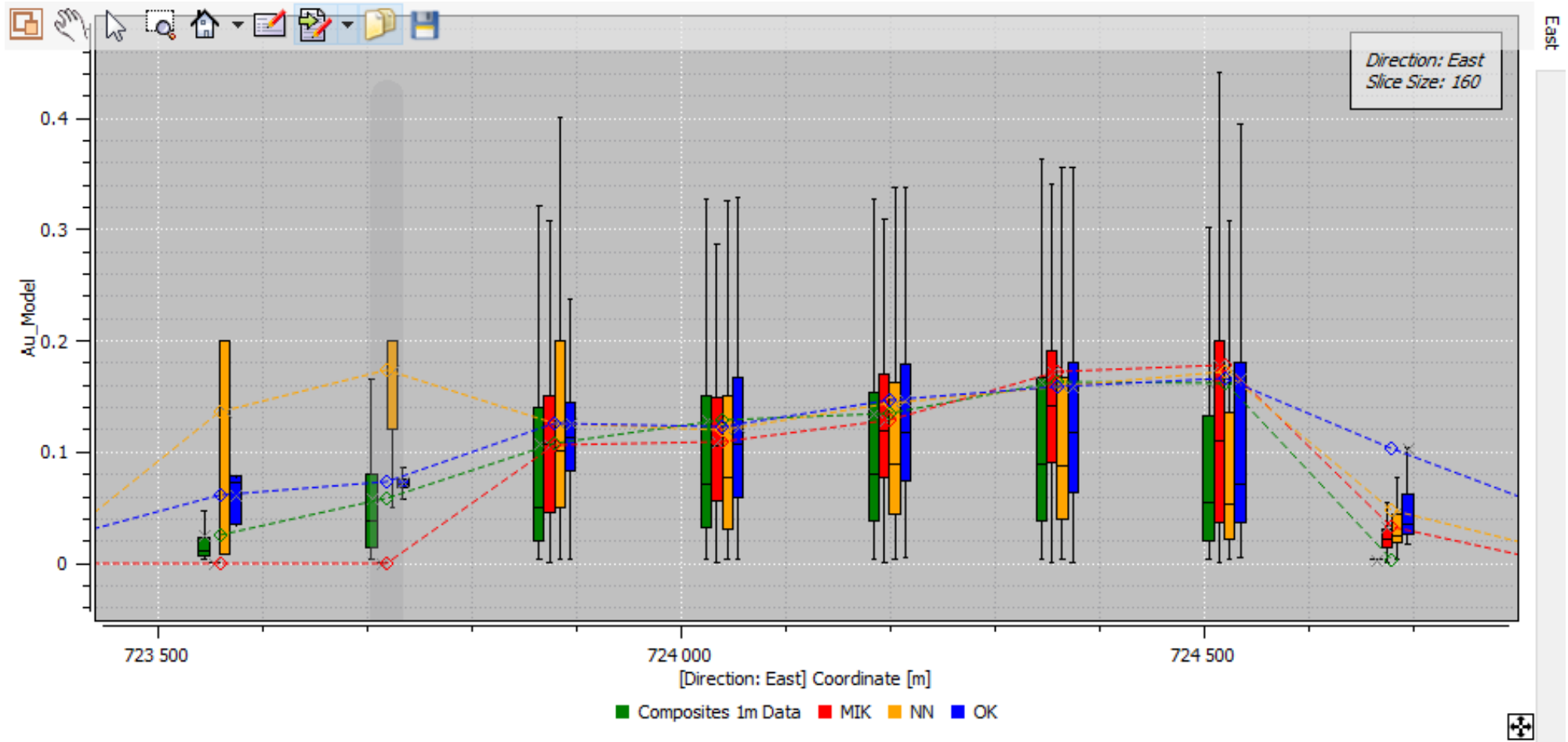

Swath Plot in the east-west direction (MIK – TriStar in red, OK GE21 in blue, NN in yellow, data in green)

Figure 14-24 Resource validation - Esperança Center region of Castelo de Sonhos

Pre-Feasibility Study

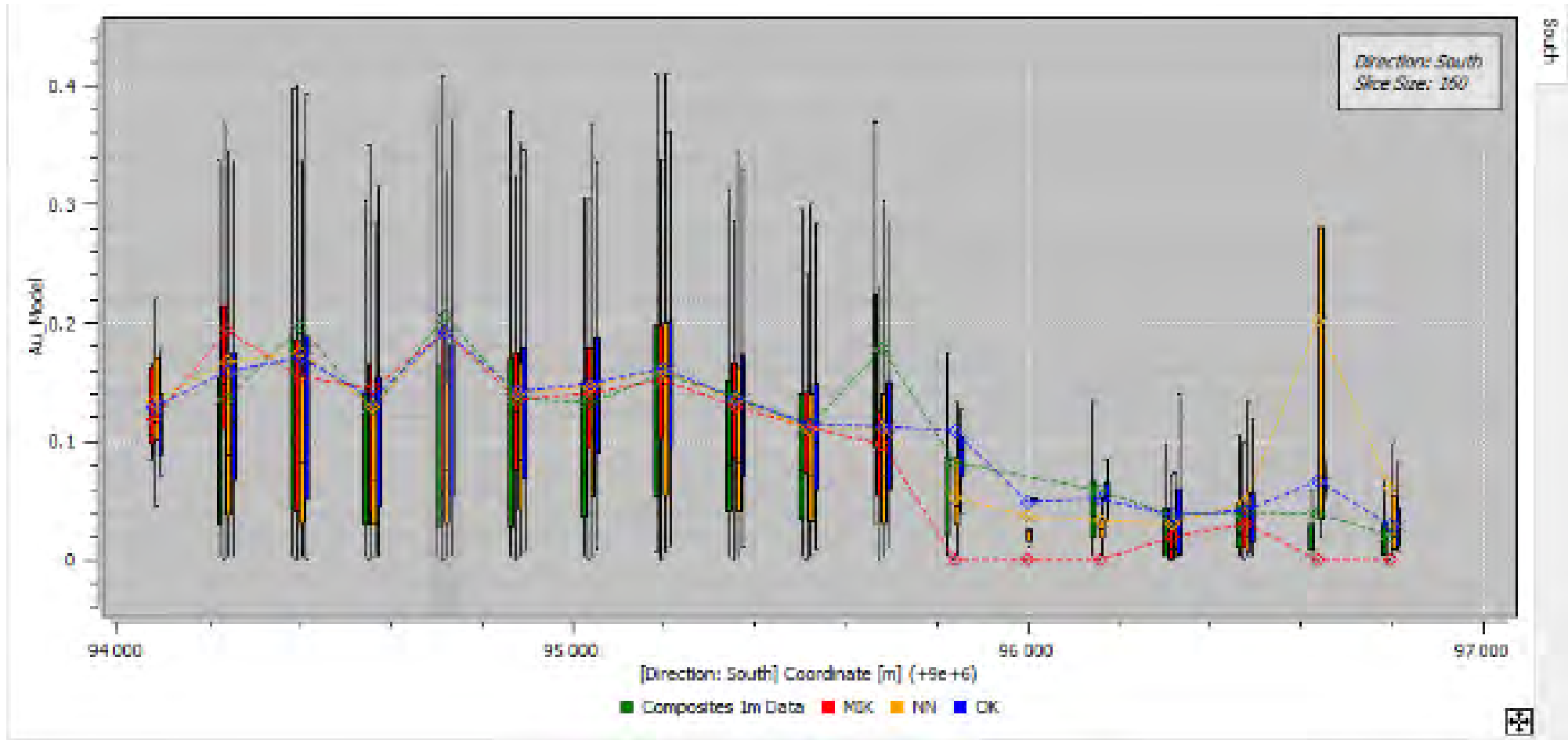

Swath Plot in the north-south direction (MIK – TriStar in red, OK GE21 in blue, NN in yellow, data in green)

Figure 14-25 Resource validation - Esperança Center region of Castelo de Sonhos

Pre-Feasibility Study

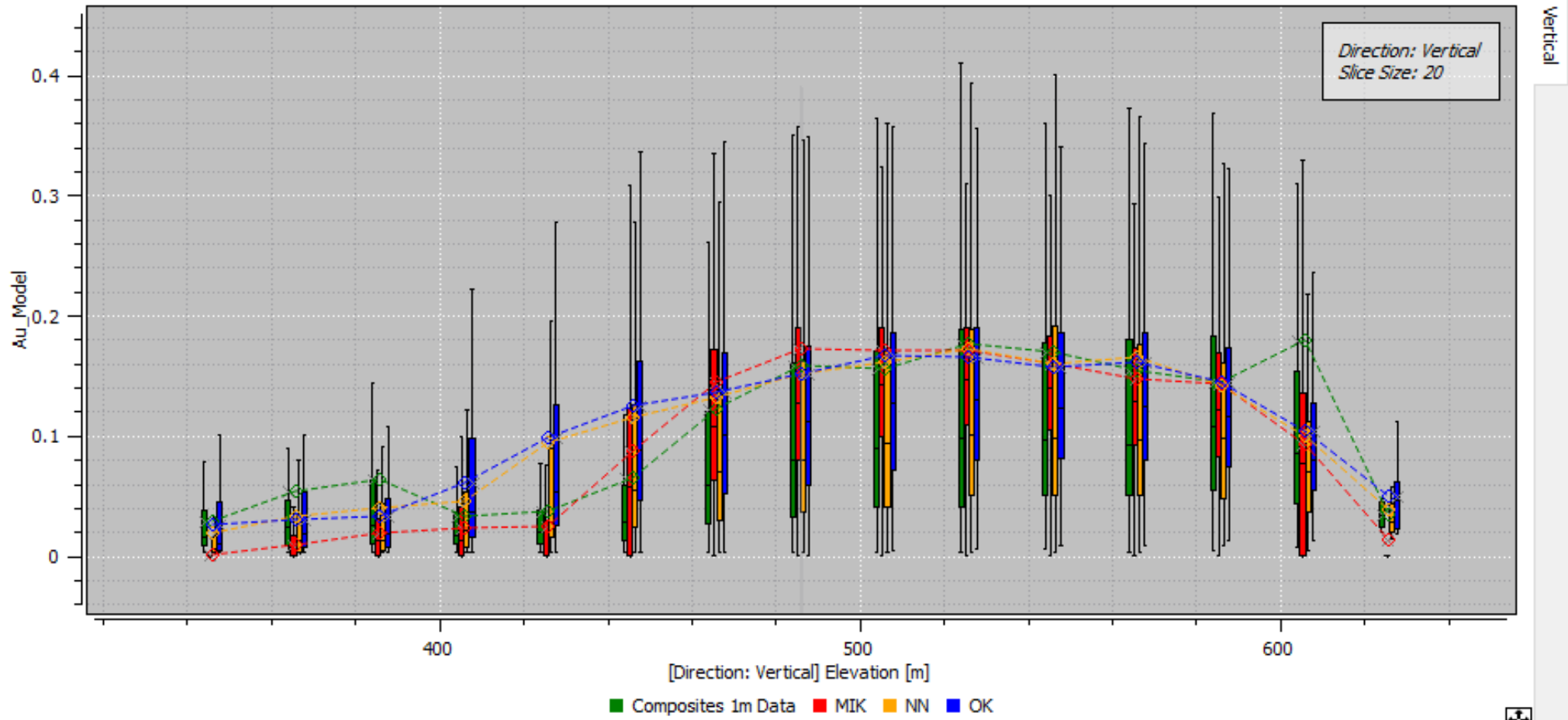

Swath Plot in the vertical direction (MIK – TriStar in red, OK GE21 in blue, NN in yellow, data in green)

Figure 14-26 Resource validation - Esperança Center region of Castelo de Sonhos

Pre-Feasibility Study

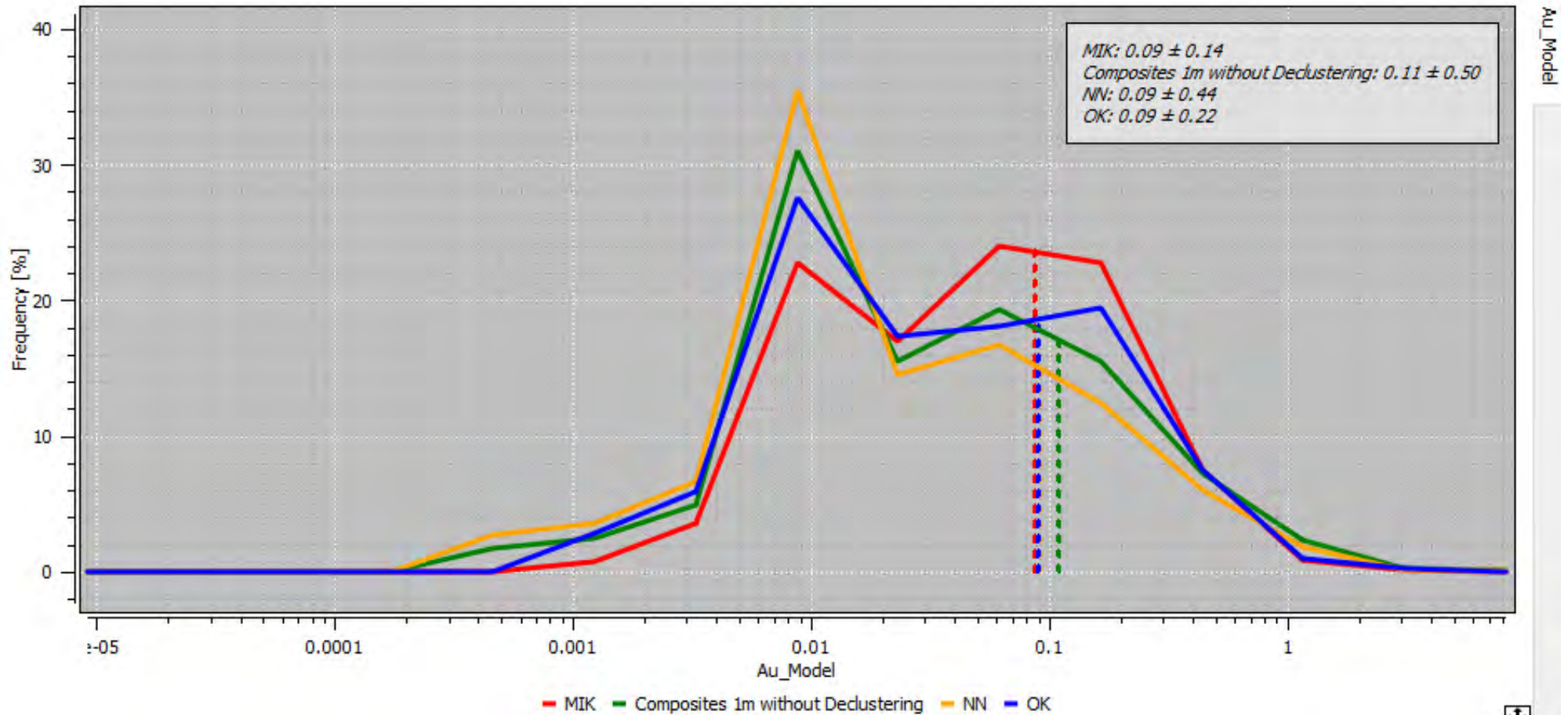

Figure 14-27 Resource validation – Esperança East region of Castelo de Sonhos. Histogram (MIK – TriStar in red, OK GE21 in blue, NN in yellow, data in green)

Pre-Feasibility Study

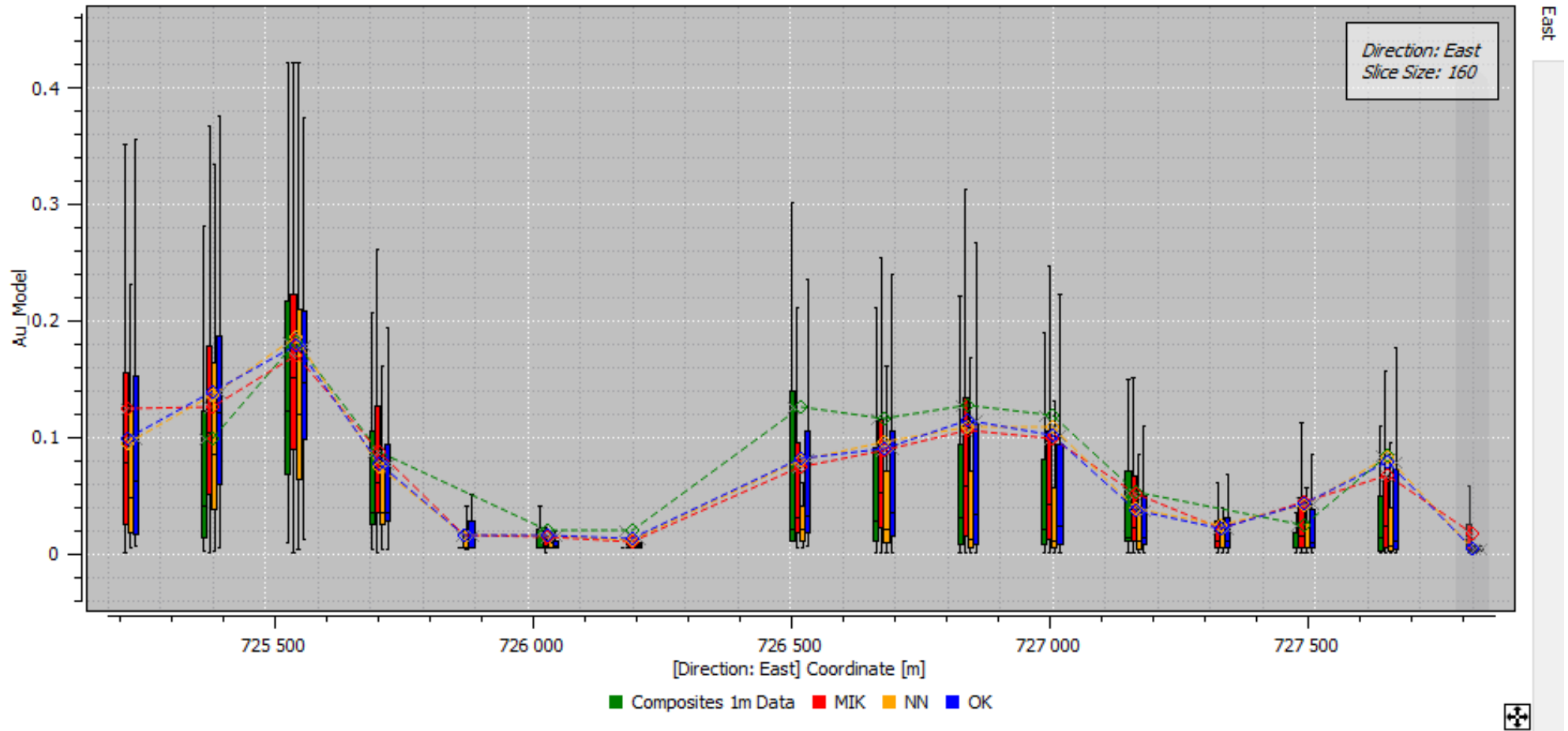

Figure 14-28 Resource validation – Esperança East region of Castelo de Sonhos - Swath Plot in the east-west direction (MIK – TriStar in red, OK GE21 in blue, NN in yellow, data in green)

Pre-Feasibility Study

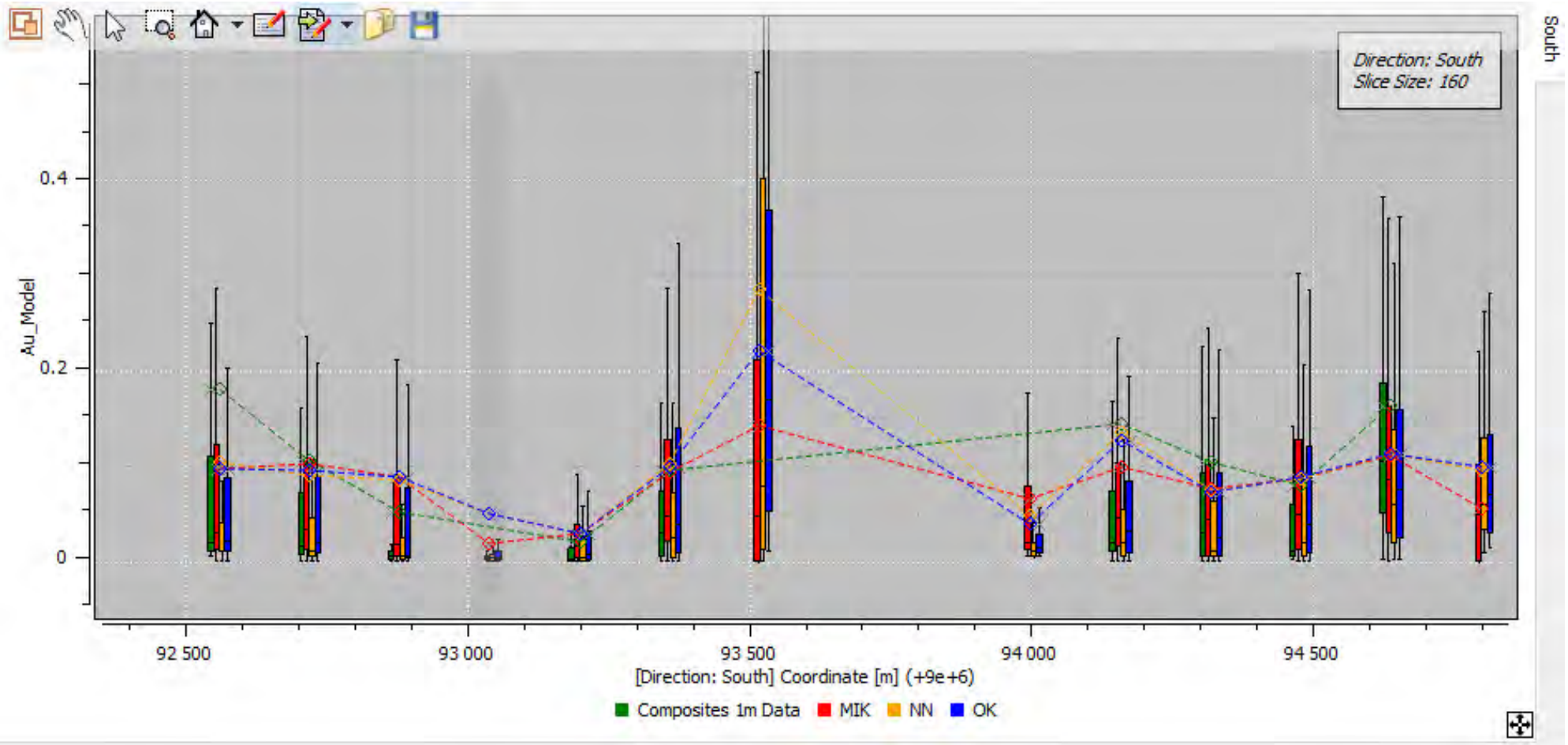

Figure 14-29 Resource validation – Esperança East region of Castelo de Sonhos - Swath Plot in the north-south direction (MIK – TriStar in red, OK GE21 in blue, NN in yellow, data in green)

Pre-Feasibility Study

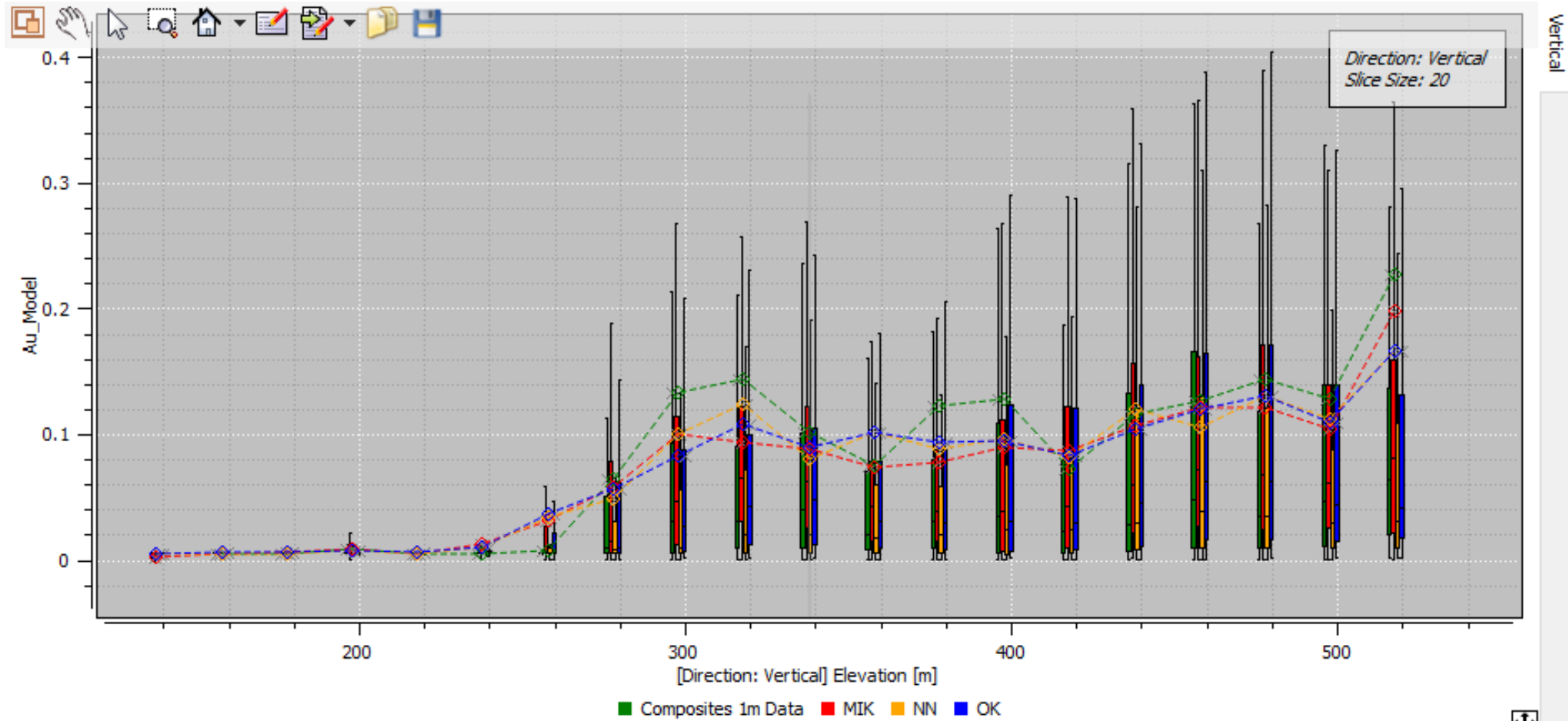

Figure 14-30 Resource validation – Esperança East region of Castelo de Sonhos - Swath Plot in the vertical direction (MIK – TriStar in red, OK GE21 in blue, NN in yellow, data in green)

Pre-Feasibility Study

14.10 Current Resource Estimate

The current resource estimates for the CDS Project are shown in Table 14-6.

Table 14-6 Mineral Resource Estimate for the Castelo de Sonhos gold project (With an effective date of October 4th, 2021) above a reporting cut-off of 0.26 g/t Au. The Qualified Person is Geol. Leonardo de Moraes Soares.

Target	Classification	Tonnage (Mt)	Grade (g/t Au)	Metal Content (Moz Au)
Esperança South	Indicated	29.0	1.28	1.19
	Inferred	10.0	1.18	0.38
Esperança East	Indicated	5.0	0.78	0.13
	Inferred	12.8	0.65	0.27
Esperança Center	Indicated	19.1	0.71	0.44
	Inferred	3.3	0.89	0.09
Project Total	Indicated	53.1	1.03	1.76
	Inferred	26.0	0.88	0.74

Notes:

1. Project totals may appear not to sum correctly since all numbers have been rounded to reflect the precision of Inferred and Indicated mineral resource estimates.
2. The reporting cut-off corresponds to the marginal cut-off grade for an open pit with processing + G&A cost of \$US 12/t, metallurgical recovery of 98% and a gold price of \$US 1,550/oz to meet the requirement of "reasonable prospect for eventual economic extraction" the mineral resources must also fall within a bounding pit shell with 55° walls.
3. These are mineral resources and not reserves and as such do not have demonstrated economic viability.
4. The metal content estimates reflect gold in situ, and do not include factors such as external dilution, mining losses and process recovery losses.
5. TriStar is not aware of any environmental, permitting, legal, title, taxation, socio-economic, marketing or political factors that might materially affect these mineral resource estimates.

Pre-Feasibility Study

14.10.1 Comparison to the previous estimate

The project-wide totals for the previous resource estimate and the updated current resource estimate are shown in Table 14-7.

Table 14-7 Comparison of current and previous resource estimates for the Castelo de Sonhos Project.

	Classification	Tonnage (Mt)	Grade (g/t Au)	Metal Content (Moz)
Current Project Total	Indicated	53.1	1.03	1.76
	Inferred	26.0	0.88	0.74
Previous Project Total	Indicated	40.1	1.2	1.5
	Inferred	22.2	1.0	0.7

Pre-Feasibility Study

15 MINERAL RESERVE ESTIMATES

Mineral Reserves on the Castelo de Sonhos Project has an effective date of October 4th, 2021. The ultimate pit and mine plan were guided by the Whittle optimization work completed by GE21. The mine plan developed in this report is based on Indicated Resources only as delineated in Section 14.

Reserves are reported using a sales price of \$1,550.00/oz of gold. Details of the assumptions, parameters and methods used in the preparation of the reserve estimate and mining schedule are presented in the Section 16.

The Mineral Reserves presented in Table 15-1 were estimated by Eng. Guilherme Gomides Ferreira of GE21, who is a qualified person under NI 43-101 and a Member of the Australian Institute of Geoscientists.

Table 15-1 Mineral Reserves
Effective date of October 4th, 2021. The Qualified Person is Eng. Guilherme Gomides Ferreira.

Area	Reserves Classification	Tonnage (Mt)	Au (g/t)	Ounces contained (Moz)
Esperança South	Probable	24.2	1.28	0.99
Esperança East	Probable	3.1	0.82	0.08
Esperança Center	Probable	11.4	0.78	0.29
Total	Probable	38.7	1.09	1.36

- The Mineral Reserve estimate for the CDS deposit was reported using the 2014 CIM Definition Standards
- Mineral Reserves were estimated using the Geovia Whittle 4.3 software and following the economic parameters:
 - Sale price gold metal = US\$1,550.00.
 - Mining costs: US\$2.17/t ore and waste mined.
 - Processing costs: US\$ 9.99/t milled.
 - Metallurgical recovery of 98%
 - G&A:US\$13.6/oz.
- Mineral Reserves are the economic portion of the Indicated Mineral Resources.
- Mass dilution 3.9%, Grade dilution 4.5%, Ore loss 0%.
- Final slope angle: 55° based on Geotechnical Document presented in Section 16.
- The Qualified Person for the estimate is Guilherme Gomides Ferreira, BSc. (MEng), MAIG, an employee of GE21.

Pre-Feasibility Study**16 MINING METHODS**

The Castelo de Sonhos Project is projected to be an open pit operation using an owned mining fleet of 70 tonnes hydraulic excavators, front-end loaders and 42 tonnes haul trucks, associated with correspondent ancillary equipment.

The disposal of waste rock will take place on areas close to the pits. The site shall be adequately prepared to include drainage at its base and channels to direct the flow of water with the aim of aiding geotechnical stability and mitigating the erosion of the stockpiled material. The operation of this phase, in accordance with the ascending method, shall begin during the construction of the heap at the base of this area. Waste rock will be disposed by truck, which will then be uniformly distributed and leveled by an operator using a tractor. The procedure is then repeated, stacking another bank above the original one, while maintaining a ramp for the trucks to be able to access the area.

The pits and waste dumps were properly scheduled to guarantee feasible mining operations during the life-of-mine and are presented on subsection 16.2. Mining dilution studies that support the Mineral Reserves statement are presented on subsection 16.3.

16.1 Geotechnical Investigation**16.1.1 Field Visit**

Field technical visit was performed by the geologist Leonardo Soares between 26th and 27th of May 2021. Geomechanical parameters related to the rock mass properties in the Castelo de Sonhos as fracturing condition, orientation and spacing, weathering and indirect strength.

During field visits the rock mass quality was checked on Esperança South garimpos, where the 3 to 10 meters depth zone are exposed RQD and fracturing spacing present high values. RQD is close to 100 and spacing is greater than 2 meters in almost exposed garimpo's pit walls (Figure 16-1 and Figure 16-2). The weathering zones in exposed faces can be defined as transition zone where the original color of minerals is partially altered but the structures are preserved.

An outcrop of conglomerate at Esperança South target is presented at Figure 16-3. The outcrop presents no fracturing at a metric scale and with high apparent strength as tested by geological hammer.

Pre-Feasibility Study



Figure 16-1 Outcrop in the border of garimpo area in the Esperança South area

Pre-Feasibility Study



Figure 16-2 Outcrop and water table in the border of garimpo area in the Esperança South area

Pre-Feasibility Study



Figure 16-3 Outcrop of conglomerates showing no fracture system in a local scale

Quartzite and conglomerates in shallow saprolitic zones as exemplified by Figure 16-4 present two fracturing sets and RQD values greater than 70%. Estimate of rock mass strength is moderate at drillcore intervals. Color of minerals are also moderately altered.

Figure 16-5 shows the transition zones with Moderate to high RQD values, and high strength zones (compact zones) with local friable intercepts with lower than 1 meter length.

Fresh rock zones presented at Figure 16-6 and Figure 16-7 show high strength, RQD and fracturing spacing, and also roughness and absence of infilling in fractures. Rock mass is interpreted as high quality by a visual check and verified by drillcore in boxes.

Pre-Feasibility Study



Figure 16-4 Drillcore boxes in the shallow saprolitic zone with two fracturing families

Pre-Feasibility Study



Figure 16-5 Drillcore box in transition from saprolitic to fresh-rock zone with local friable intercepts (shallow than 43m depth).

Pre-Feasibility Study



Figure 16-6 Drillcore box in fresh rock zone showing conglomerate intercept

Pre-Feasibility Study



Figure 16-7 Drillcore boxes showing fresh rock zone with one fracturing family with high RQD values and high fracturing spacing

16.1.2 Rock Mass Classification

The pits of the Castelo de Sonhos Gold Project will be in a rock mass composed by silicified sandstones and conglomerates, with two main discontinuity structures with low dip angles, 24/286 and 17/035 Figure 16-8. This structural data was selected from OTV data from holes CSH-12-061, RC-17-192, RC-17-221, RC-17-286, RC-17-358 and RC-20-523.

Pre-Feasibility Study

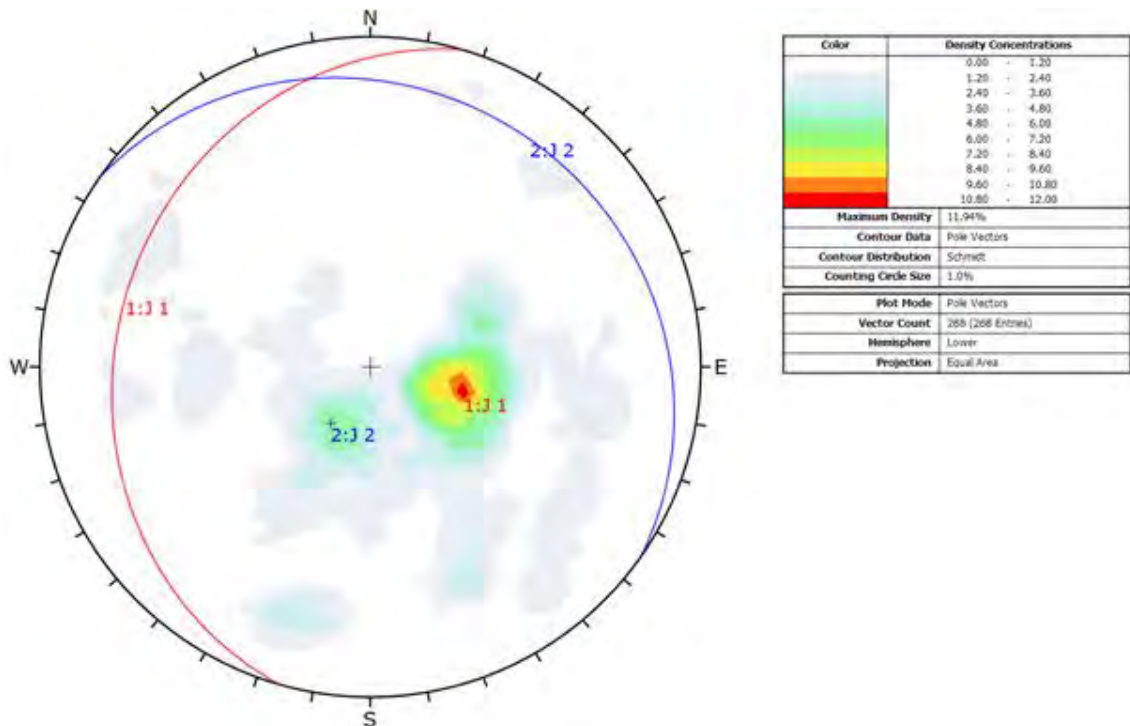

Figure 16-8 Stereogram from OTV surveyed structures showing two main structures, 24/286 and 17/035.

The soil overburden is thin, less than 5 m, with locally outcropping sandstone and conglomerate.

The rock mass has a good to excellent RQD (75 – 100%), medium fracturing class (F3), and good rock mass rating (Class II).

The selected geomechanical parameters for silicified sandstone/conglomerate were based on geological images and structures obtained by the OTV system, uniaxial compression tests (UCS) and tensile tests on samples (Table 16-1, Table 16-2 and Table 16-3).

Pre-Feasibility Study

Table 16-1 Uniaxial compressive test results (UCS).

Code	Height (mm)	Diameter (mm)	UCS (MPa)	Young Modulus (GPa)	Poisson's Ratio
CP_01	128.5	47.35	132.38	61.3	0.119
CP_02	127.48	47.55	101.71	56.12	0.172
CP_03	127.65	47.45	53.44	54.98	0.103
CP_04	127.9	47.48	108.5	53.74	0.166
CP_05	127.98	47.4	116.83	62.32	0.169
CP_06	127.51	47.47	94.06	57.11	0.232
CP_07	127.56	47.43	100.66	60.2	0.161
CP_08	128.45	47.53	163.83	71.03	0.16
CP_09	136.18	50.38	177.33	72.28	0.162
CP_10	135.73	50.4	181.43	76.58	0.173
		S.Dev.	38.15	7.47	0.03
		Mean	123.02	67.44	0.18
		C.V.	0.31	0.11	0.16

As the result of the UCS test had a very high standard deviation, the last three samples CP 08, CP 09 and CP 10 were purged, resulting in more uniform values, according to Table 16-2

Table 16-2 Uniaxial compression test (UCS) purged

Code	Height (mm)	Diameter (mm)	UCS (MPa)	Young Modulus (GPa)	Poisson's Ratio
CP_01	128.5	47.35	132.38	61.3	0.119
CP_02	127.48	47.55	101.71	56.12	0.172
CP_03	127.65	47.45	53.44	54.98	0.103
CP_04	127.9	47.48	108.5	53.74	0.166
CP_05	127.98	47.4	116.83	62.32	0.169
CP_06	127.51	47.47	94.06	57.11	0.232
CP_07	127.56	47.43	100.66	60.2	0.161
		S.Dev.	22.68	3.07	0.04
		Mean	101.08	57.97	0.16
		C.V.	0.22	0.05	0.24

Pre-Feasibility Study

Table 16-3 Indirect tensile strength test

Code	Height (mm)	Diameter (mm)	Indirect tensile strength (MPa)
CP_01	24.72	47.47	4.473
CP_02	23.90	47.43	13.331
CP_03	76.1	47.37	5.896
CP_04	24.93	47.33	8.095
CP_05	25.58	47.42	5.730
CP_06	24.82	47.43	6.883
CP_07	23.95	47.40	8.883
CP_08	24.17	47.40	13.430
CP_09	24.67	50.38	10.821
CP_10	23.47	50.28	10.583
S. Dev.			3.16
Mean			8.81
C.V.			0.36

Samples CP02, CP08, CP09 and CP10 were also excluded from the analysis. After this outlier treatment, the distribution of results presents lower coefficient of variation, as shown in Table 16-4.

Table 16-4 Indirect tensile strength test

Sample Code	Sample Length (mm)	Diameter (mm)	Indirect Tensile Strength (MPa)
CP_01	24.72	47.47	4.473
CP_03	76.1	47.37	5.896
CP_04	24.93	47.33	8.095
CP_05	25.58	47.42	5.73
CP_06	24.82	47.43	6.883
CP_07	23.95	47.4	8.883
S. Dev.			1.63
Mean			6.66
C.V.			0.24

In the stability analyses, the UCS of 100 MPa, 58 GPa of Young Modulus, 0.16 of Poisson's Ratio and 6 MPa of indirect tensile strength were adopted.

Castelo de Sonhos project rock mass was considered as a single lithological domain. Therefore, the silicified sandstone and the conglomerate were grouped in the same unit, as they have similar mechanical behavior.

With the test data, the simple compressive strength of the intact rock (σ_{ci}) was defined, using RocLab Table 16-5 presents the intact rock parameters.

Table 16-5 Intact rock parameters

Parameter	Value	Observation
Specific gravity γ (kN/m ³)	26.8	Previous reports
Intact rock strength σ_{ci} (MPa)	100	UCS test
Material constant m_i	11	RocLab

Pre-Feasibility Study

RocLab Rocscience Software (Figure 16-9) was used to determine the rock mass rupture criteria based on the properties of the intact rock using the Hoek-Brown classification with the determination of the GSI (Geological Strength Index), Damage Factor due to detonation (D). The resulting values are found in the Table 16-6.

Table 16-6 Rock mass properties

Parameters		Values	Observation
Hoek-Brown	σ_{ci} MPa	100	UCS tests
Classification	GSI	53	RocLab
	m_i	11	RocLab
	D	1	RocLab
Hoek-Brown	m_b	0.357	RocLab
Criterion	s	0.0003	RocLab
	a	0.505	RocLab

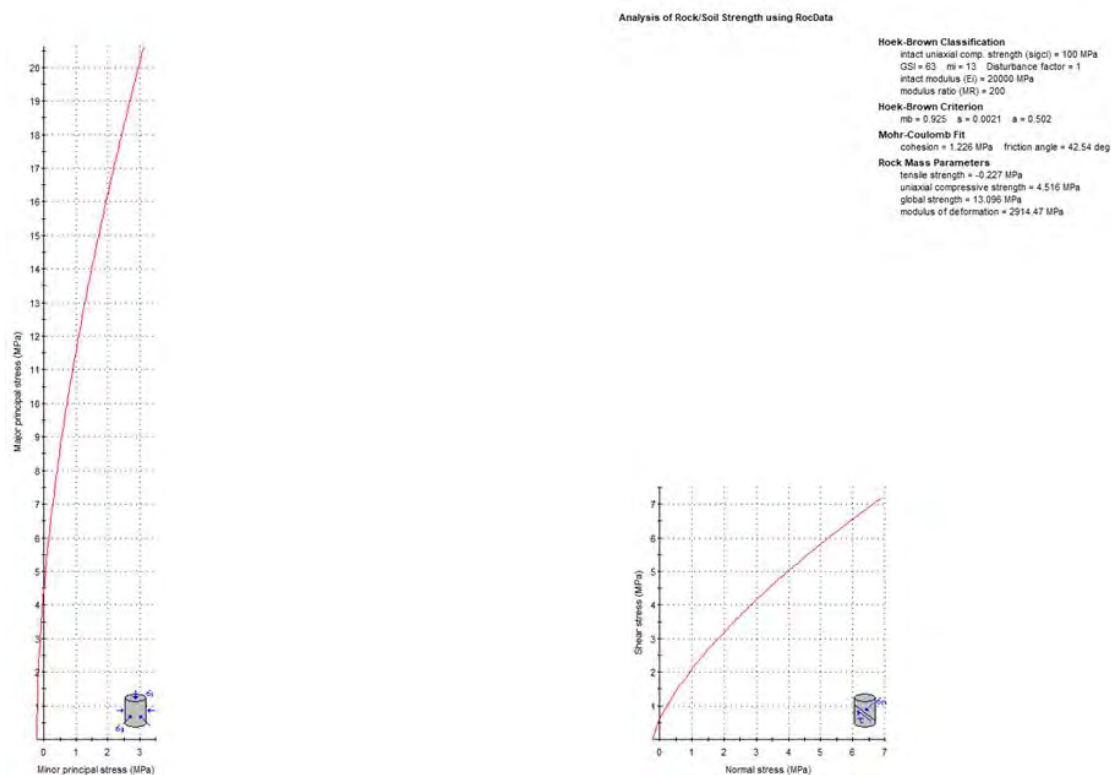

Figure 16-9 Results obtained with RocData.

16.1.2.1 Pit Design Parameters

A number of 6 pits were defined along the mineralized body where kinematic and limit-equilibrium stability analyses were performed.

Pre-Feasibility Study

The strength parameters were defined using the data obtained in the UCS and Indirect Tensile tests through RocData 4.0 are presented in Table 16-1 to Table 16-4. and Figure 16-9.

The selected parameters were defined as more conservative, with 400 MPa of cohesion and a 35° angle of friction. Figure 16-10 shows the pits of the Castelo de Sonhos project.

For the stability analysis, the following conditions were assumed:

- The rock mass was considered as an isotropic material
- Slope partially saturated

Pre-Feasibility Study

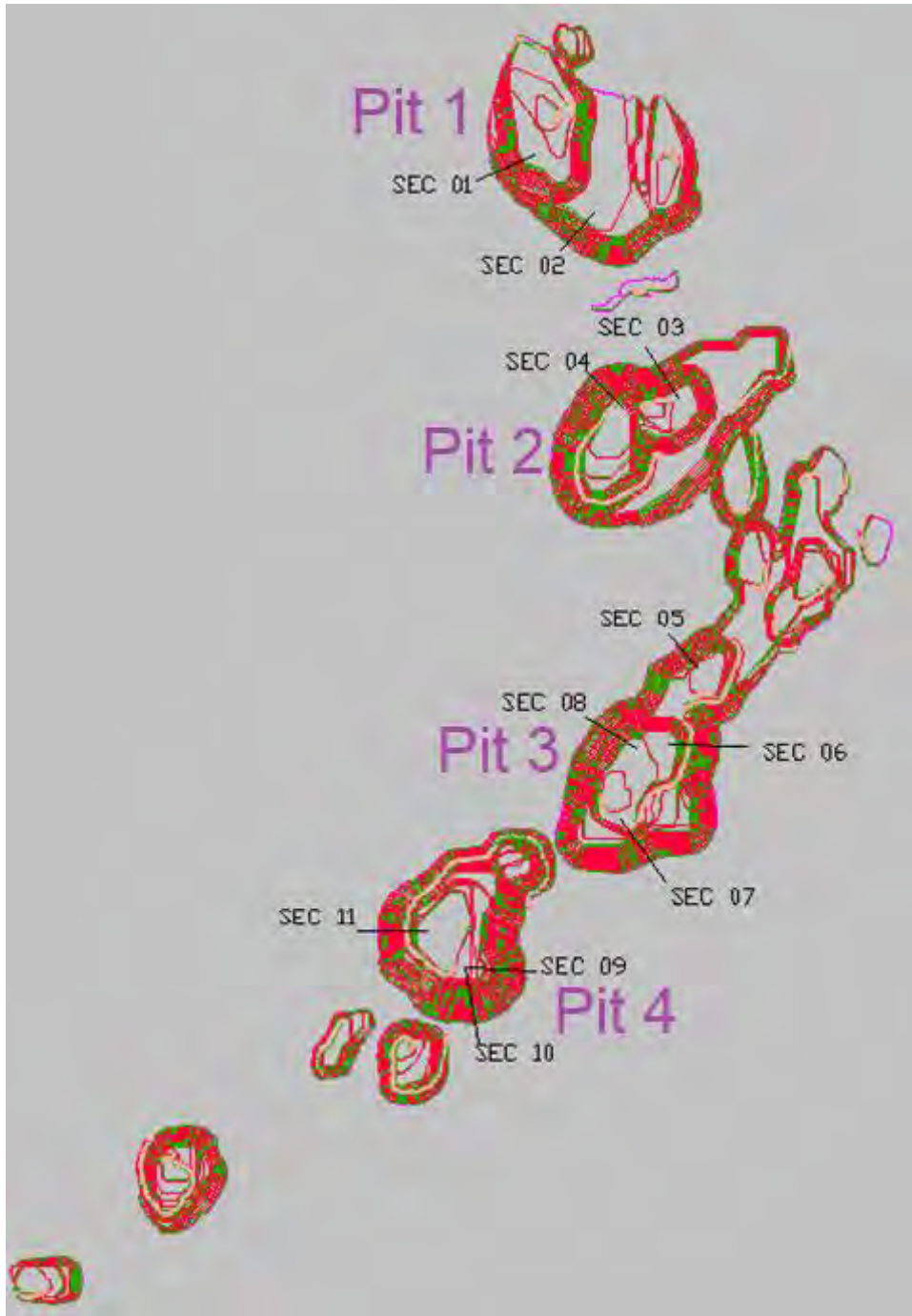

Figure 16-10 Castelo de Sonhos Project open pits.

Pre-Feasibility Study

16.1.3 Kinematic and Stability Analysis – Pit 1

Kinematic and slope stability analysis were performed for Pit 1, on slopes T1 (74/040), T2 (75/340) and T3 (75/270) by the sections 01 and 02 (Figure 16-11).

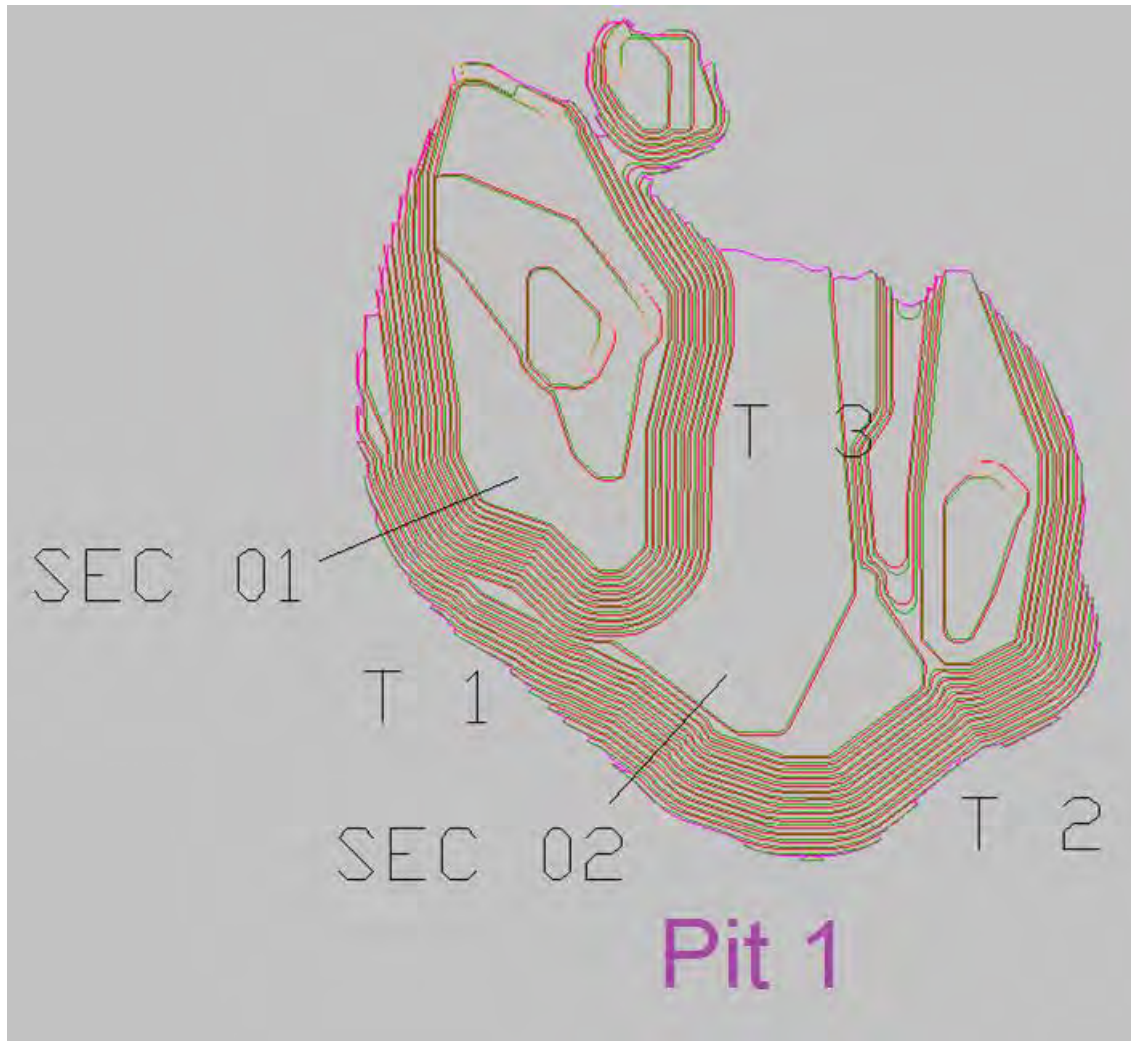

Figure 16-11 Pit 1 sectors.

Kinematic tests were performed to evaluate planar, toppling and wedge ruptures. The friction angle adopted was obtained from RocLab, Cohesion of 400 MPa and friction angle of 35°. Figure 16-12 to Figure 16-20 show the analysis for the sectors and the respective percentages of occurrences.

Pre-Feasibility Study

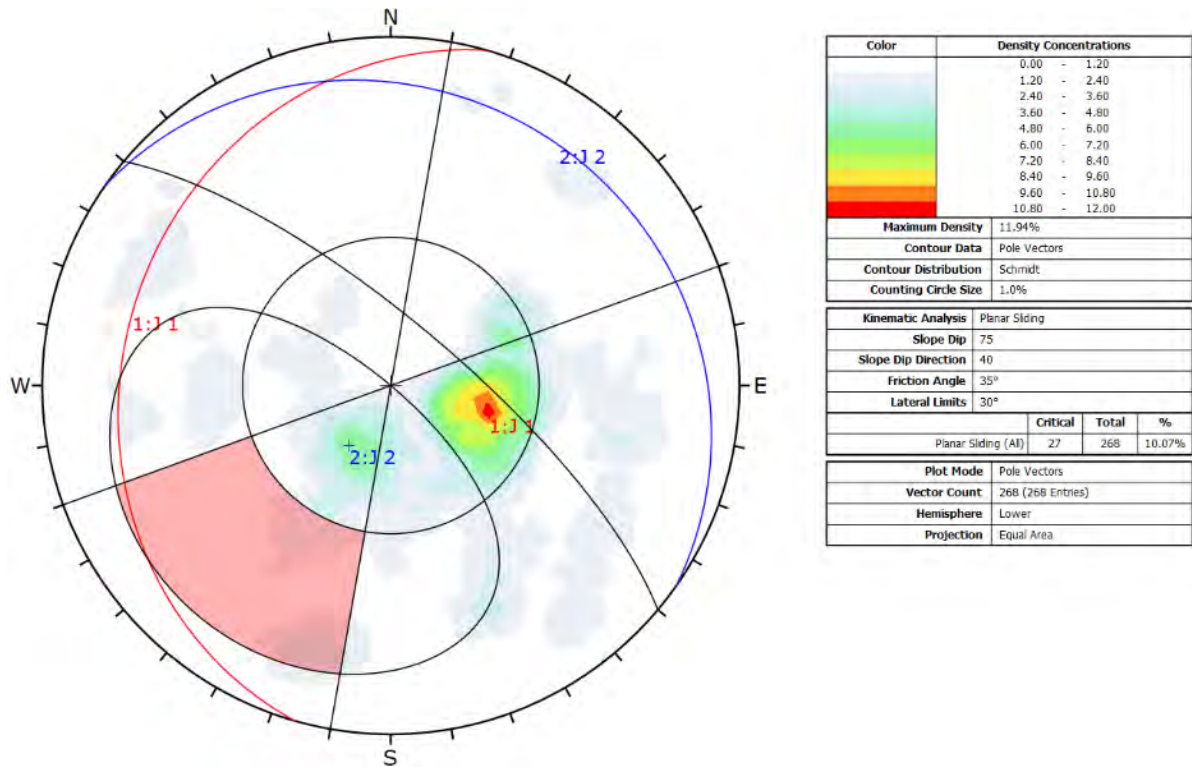

Figure 16-12 Kinematic analysis for the slope T1 showing 10% of probability for planar rupture

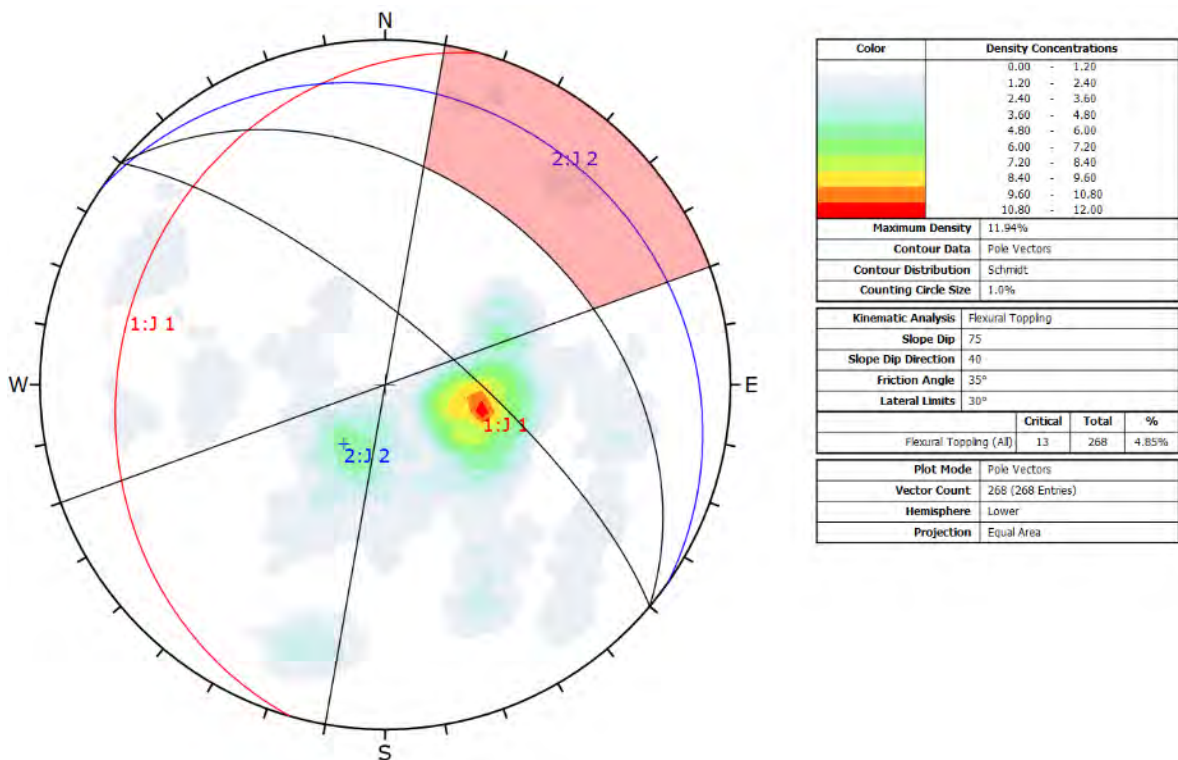

Figure 16-13 Kinematic analysis for the slope T1 showing 4% of probability for toppling rupture

Pre-Feasibility Study

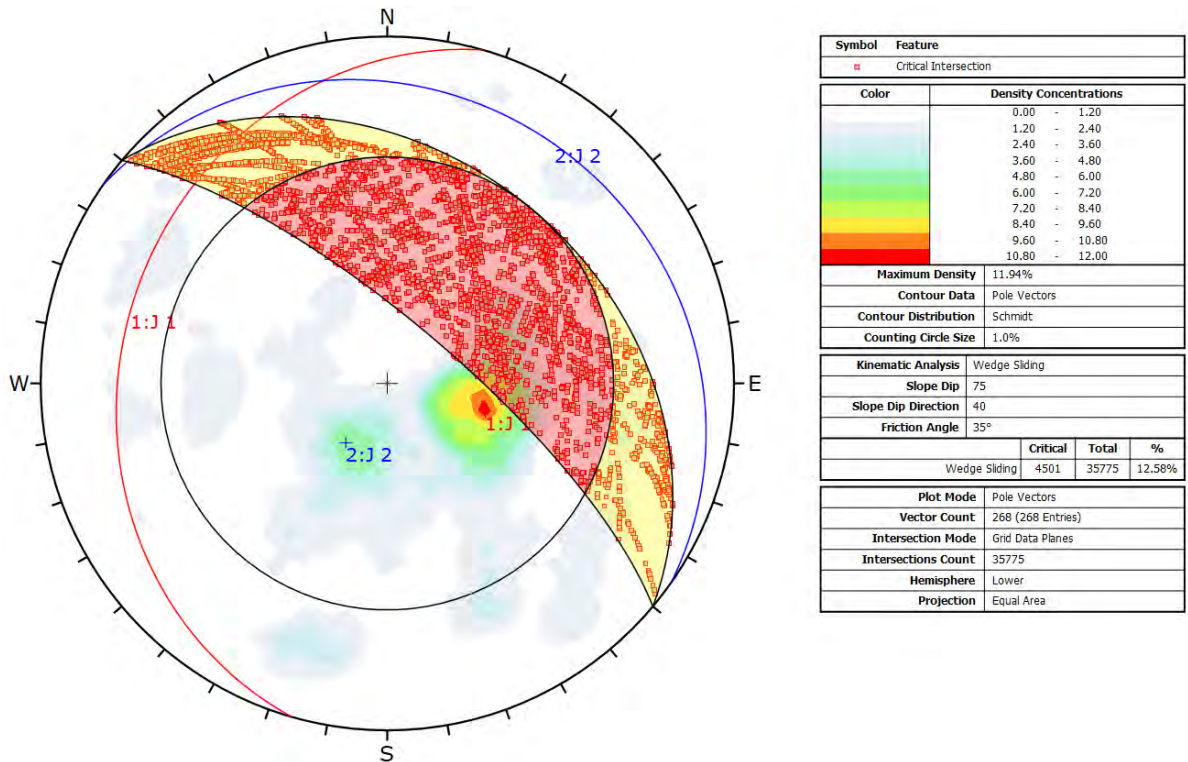

Figure 16-14 Kinematic analysis for the slope T1 showing 12% of probability for wedge rupture

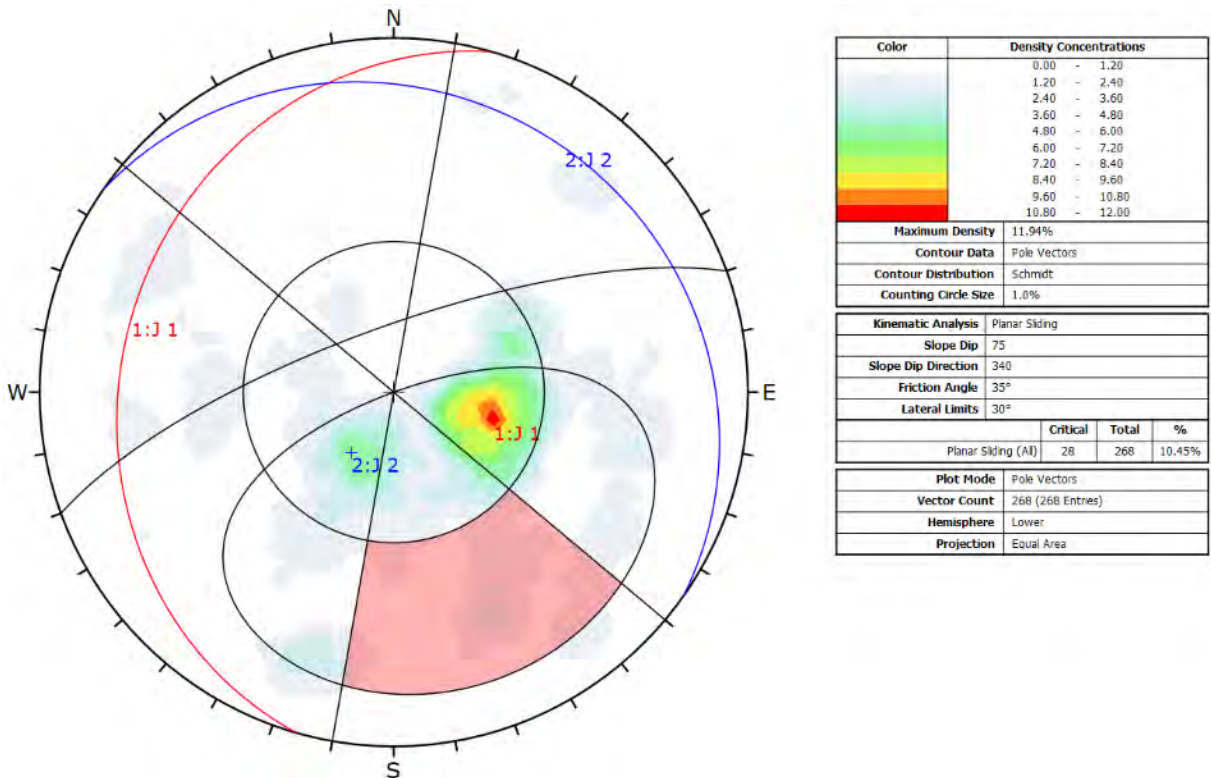
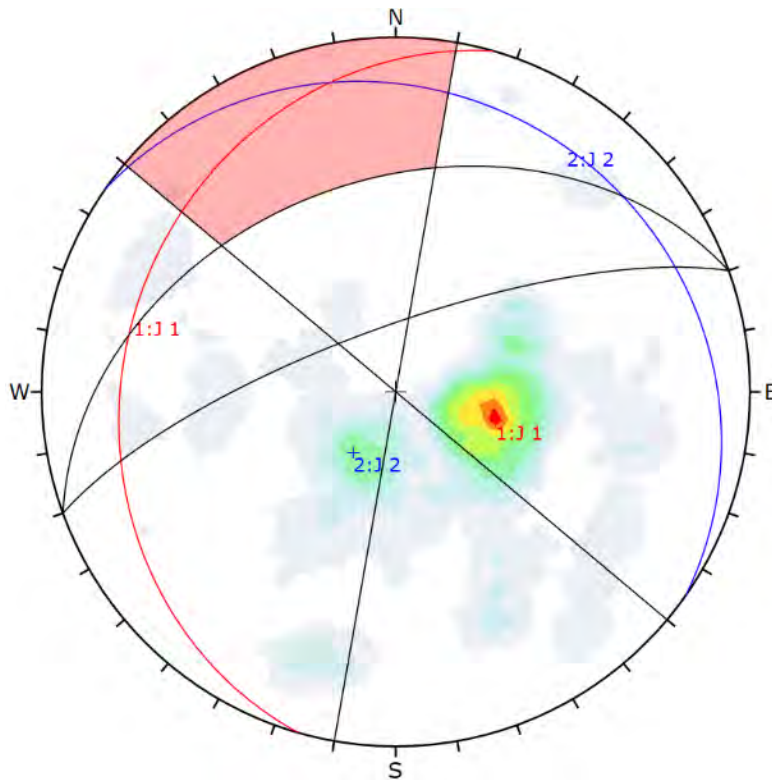

Figure 16-15 Kinematic analysis for the slope T2 showing 10% of probability for planar rupture

Pre-Feasibility Study



Color	Density Concentrations
	0.00 - 1.20
	1.20 - 2.40
	2.40 - 3.60
	3.60 - 4.80
	4.80 - 6.00
	6.00 - 7.20
	7.20 - 8.40
	8.40 - 9.60
	9.60 - 10.80
	10.80 - 12.00

Maximum Density	11.94%
Contour Data	Pole Vectors
Contour Distribution	Schmidt
Counting Circle Size	1.0%

Kinematic Analysis	Flexural Topping
Slope Dip	75
Slope Dip Direction	340
Friction Angle	35°
Lateral Limits	30°

	Critical	Total	%
Flexural Topping (All)	9	268	3.36%

Plot Mode	Pole Vectors
Vector Count	268 (268 Entries)
Hemisphere	Lower
Projection	Equal Area

Figure 16-16 Kinematic analysis for the slope T2 showing 3% of probability for toppling rupture

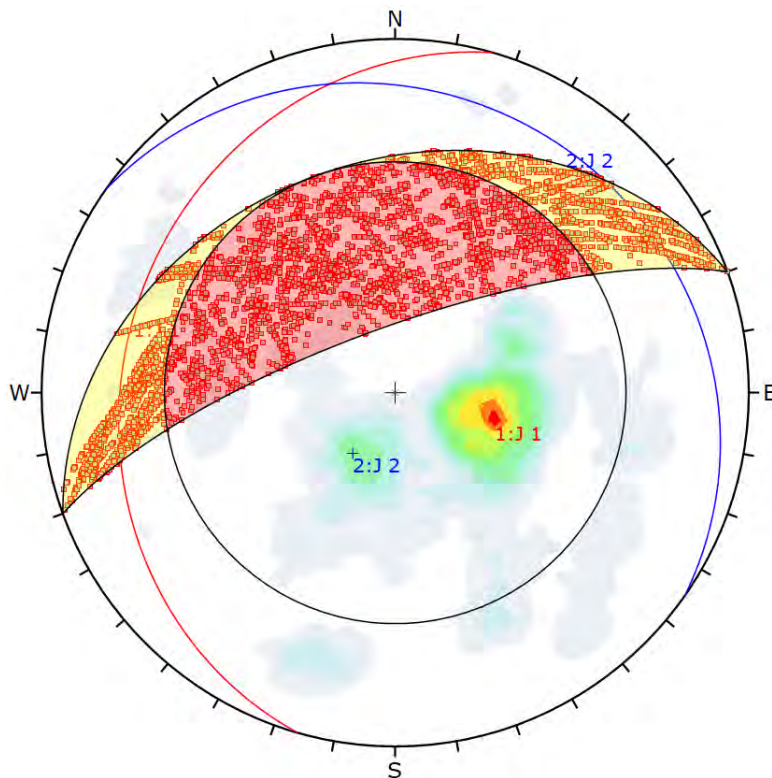

Symbol	Feature
■	Critical Intersection

Color	Density Concentrations
	0.00 - 1.20
	1.20 - 2.40
	2.40 - 3.60
	3.60 - 4.80
	4.80 - 6.00
	6.00 - 7.20
	7.20 - 8.40
	8.40 - 9.60
	9.60 - 10.80
	10.80 - 12.00

Maximum Density	11.94%
Contour Data	Pole Vectors
Contour Distribution	Schmidt
Counting Circle Size	1.0%

Kinematic Analysis	Wedge Sliding
Slope Dip	75
Slope Dip Direction	340
Friction Angle	35°

	Critical	Total	%
Wedge Sliding	5760	35775	16.10%

Plot Mode	Pole Vectors
Vector Count	268 (268 Entries)
Intersection Mode	Grid Data Planes
Intersections Count	35775
Hemisphere	Lower
Projection	Equal Area

Figure 16-17 Kinematic analysis for the slope T2 showing 16% of probability for wedge rupture

Pre-Feasibility Study

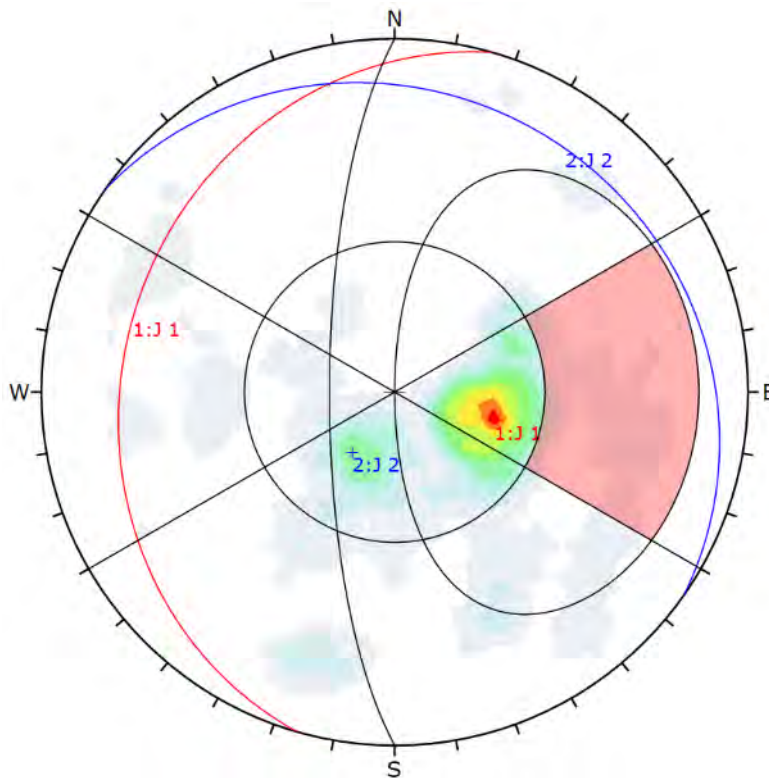

Color	Density Concentrations		
	0.00 - 1.20		
	1.20 - 2.40		
	2.40 - 3.60		
	3.60 - 4.80		
	4.80 - 6.00		
	6.00 - 7.20		
	7.20 - 8.40		
	8.40 - 9.60		
	9.60 - 10.80		
	10.80 - 12.00		
Maximum Density	11.94%		
Contour Data	Pole Vectors		
Contour Distribution	Schmidt		
Counting Circle Size	1.0%		
Kinematic Analysis	Planar Sliding		
Slope Dip	75		
Slope Dip Direction	270		
Friction Angle	35°		
Lateral Limits	30°		
	Critical	Total	%
Planar Sliding (All)	24	268	8.96%
Plot Mode	Pole Vectors		
Vector Count	268 (268 Entries)		
Hemisphere	Lower		
Projection	Equal Area		

Figure 16-18 Kinematic analysis for the slope T3 showing 9% of probability for planar rupture

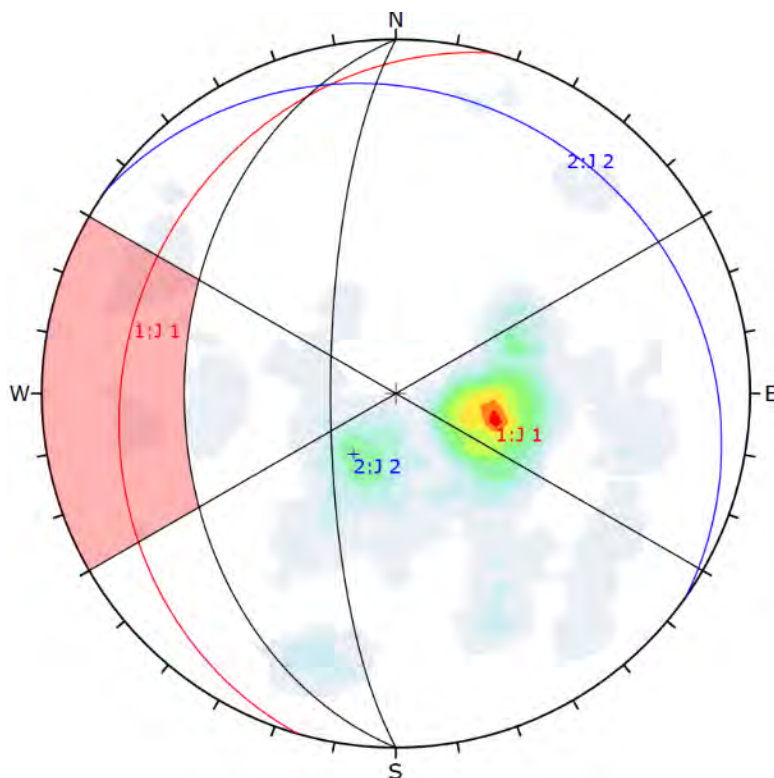

Color	Density Concentrations		
	0.00 - 1.20		
	1.20 - 2.40		
	2.40 - 3.60		
	3.60 - 4.80		
	4.80 - 6.00		
	6.00 - 7.20		
	7.20 - 8.40		
	8.40 - 9.60		
	9.60 - 10.80		
	10.80 - 12.00		
Maximum Density	11.94%		
Contour Data	Pole Vectors		
Contour Distribution	Schmidt		
Counting Circle Size	1.0%		
Kinematic Analysis	Flexural Toppling		
Slope Dip	75		
Slope Dip Direction	270		
Friction Angle	35°		
Lateral Limits	30°		
	Critical	Total	%
Flexural Toppling (All)	22	268	8.21%
Plot Mode	Pole Vectors		
Vector Count	268 (268 Entries)		
Hemisphere	Lower		
Projection	Equal Area		

Figure 16-19 Kinematic analysis for the slope T3 showing 8% of probability for toppling rupture

Pre-Feasibility Study

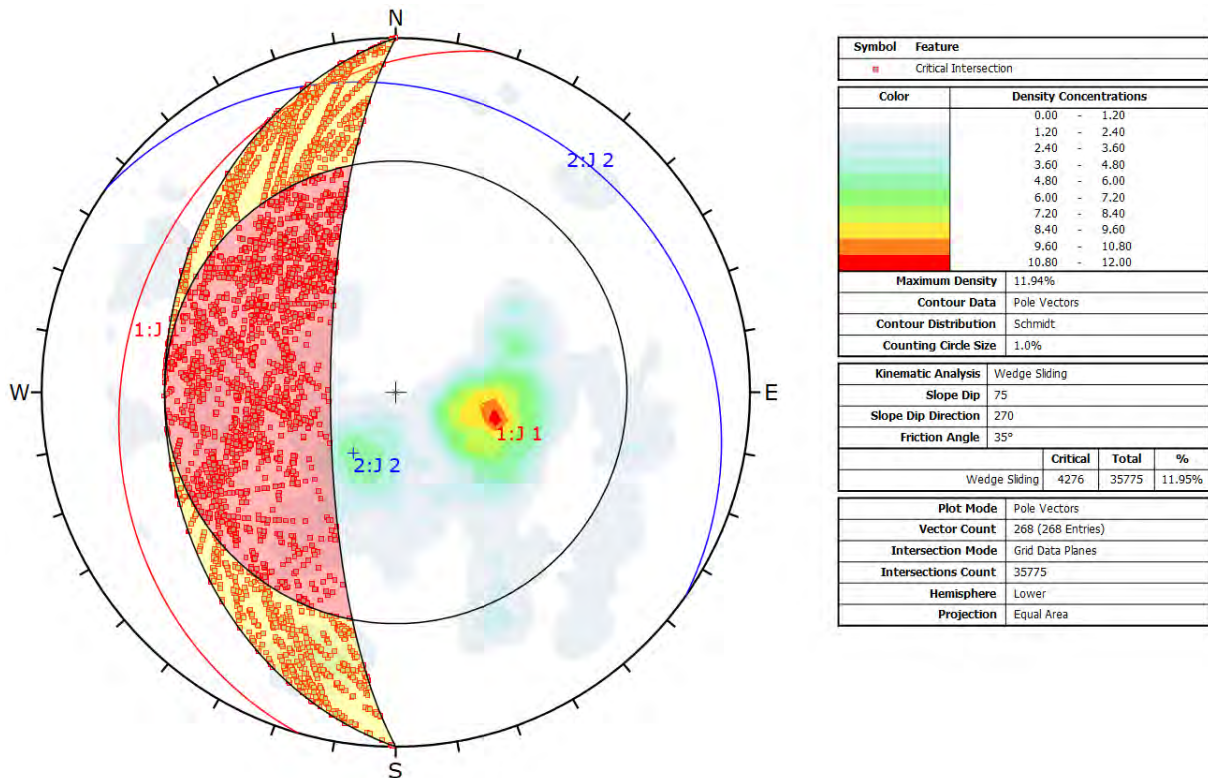

Figure 16-20 Kinematic analysis for the slope T3 showing 12% of probability for wedge rupture

Limit-equilibrium slope stability analysis were performed for Pit 1 on sections 01 and 02 at the highest height of the slopes, adopting the parameters obtained in RocLab software. The results of the analysis are shown in Figure 16-21 and Figure 16-22.

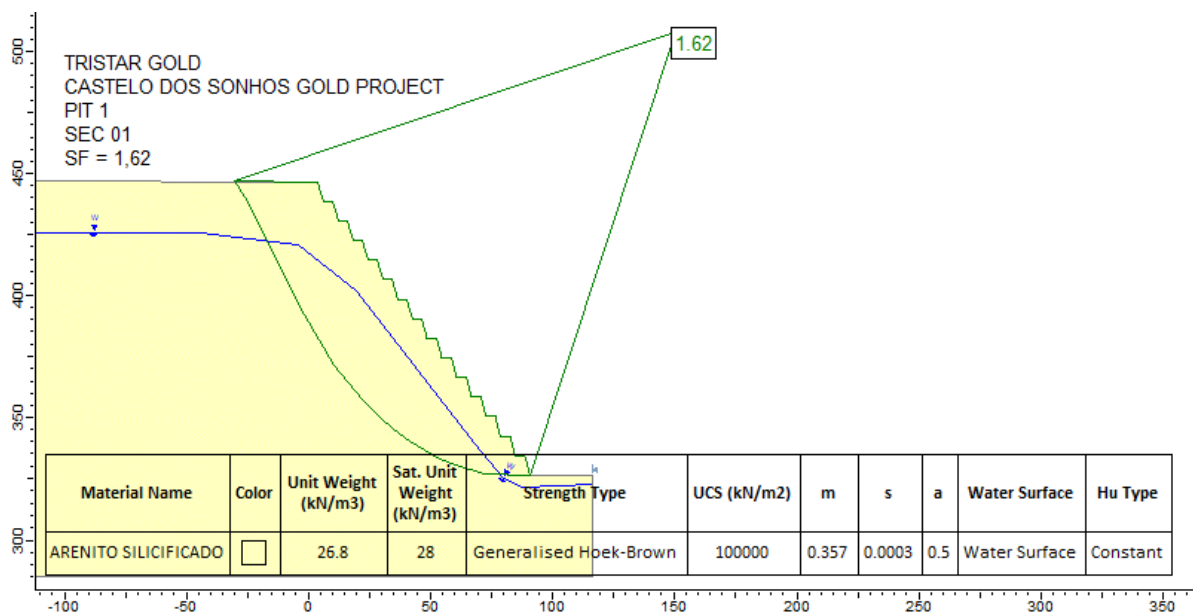

Figure 16-21 Limit-equilibrium analysis results for Section 01 with FS (security factor) = 1.62

Pre-Feasibility Study

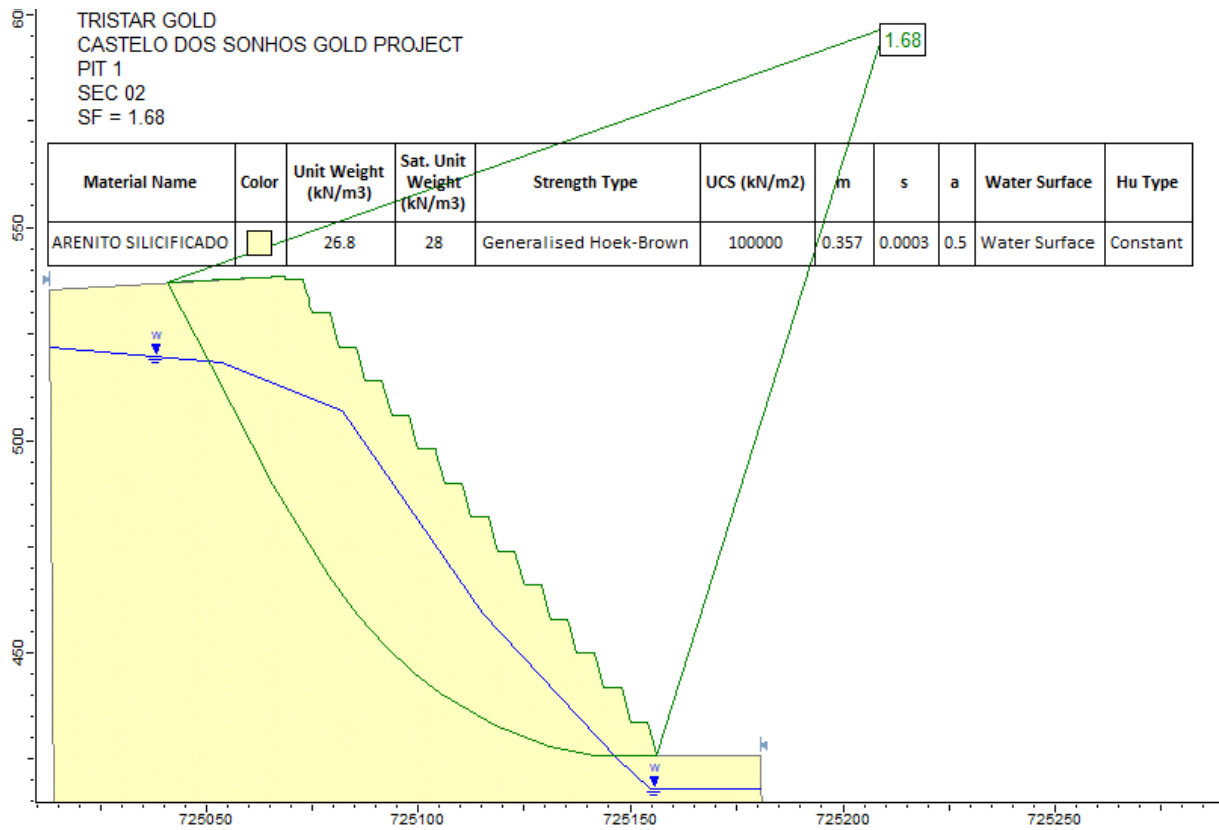

Figure 16-22 Limit-equilibrium analysis results for Section 02 with FS (security factor) = 1.68

Pre-Feasibility Study**16.1.4 Kinematic and Stability Analysis – Pit 2**

Kinematic and slope stability analysis were performed for Pit 2, on slopes T4 (75/120), T5 (75/080) by the sections 03 and 04 (Figure 16-23).

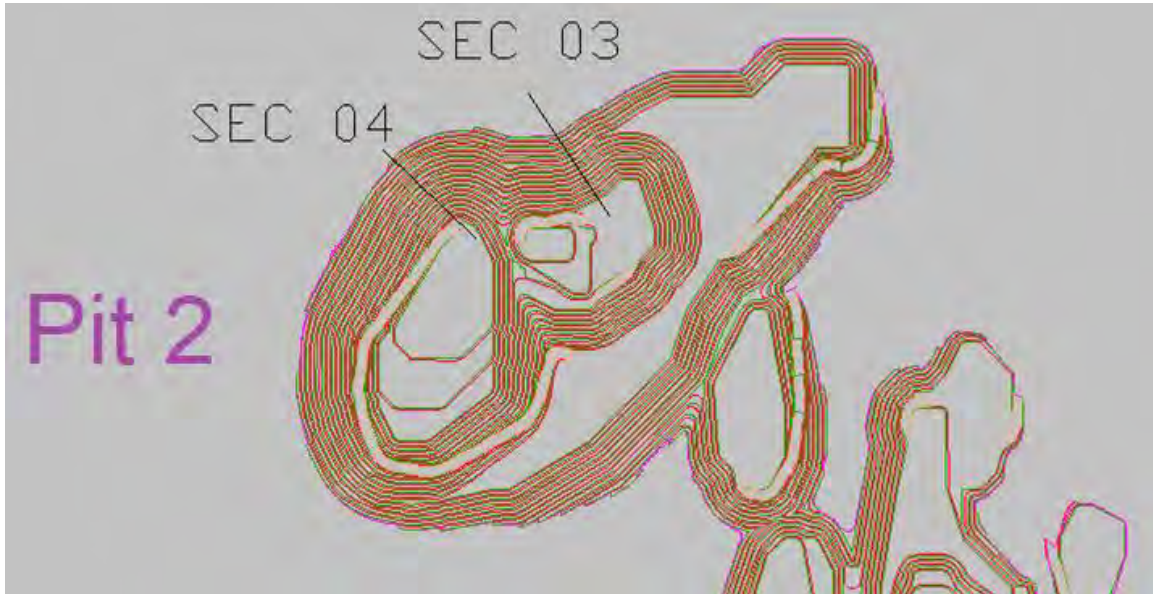
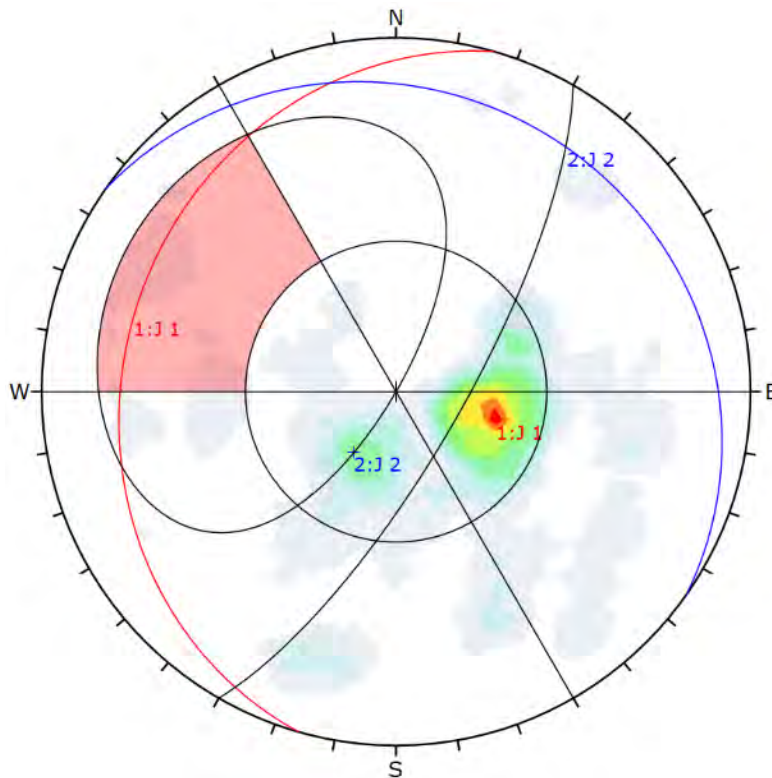

Figure 16-23 Pit 2 sectors

Kinematic analyses were performed to evaluate planar, toppling and wedge ruptures. The friction angle adopted was obtained from RocLab, Cohesion of 400MPa and friction angle of 35°. Figure 16-24 to Figure 16-29 show the analysis for the sectors and the respective percentages of occurrences.

Pre-Feasibility Study



Color	Density Concentrations
	0.00 - 1.20
	1.20 - 2.40
	2.40 - 3.60
	3.60 - 4.80
	4.80 - 6.00
	6.00 - 7.20
	7.20 - 8.40
	8.40 - 9.60
	9.60 - 10.80
	10.80 - 12.00
Maximum Density 11.94%	
Contour Data Pole Vectors	
Contour Distribution Schmidt	
Counting Circle Size 1.0%	
Kinematic Analysis Planar Sliding	
Slope Dip 75	
Slope Dip Direction 120	
Friction Angle 35°	
Lateral Limits 30°	
	Critical Total %
Planar Sliding (All)	17 268 6.34%
Plot Mode Pole Vectors	
Vector Count 268 (268 Entries)	
Hemisphere Lower	
Projection Equal Area	

Figure 16-24 Kinematic analysis for the slope T4 showing 6% of probability for planar rupture

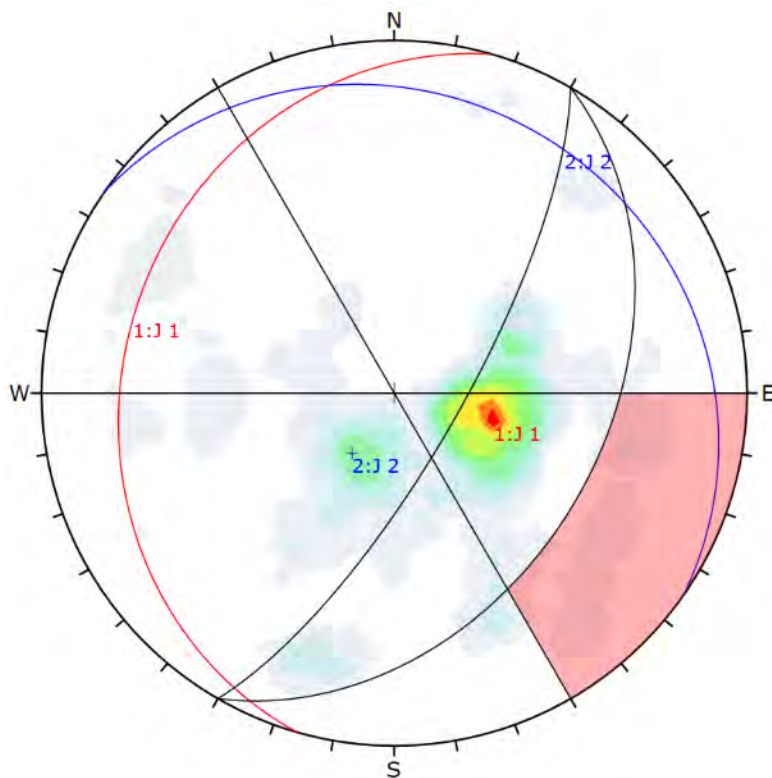

Color	Density Concentrations
	0.00 - 1.20
	1.20 - 2.40
	2.40 - 3.60
	3.60 - 4.80
	4.80 - 6.00
	6.00 - 7.20
	7.20 - 8.40
	8.40 - 9.60
	9.60 - 10.80
	10.80 - 12.00
Maximum Density 11.94%	
Contour Data Pole Vectors	
Contour Distribution Schmidt	
Counting Circle Size 1.0%	
Kinematic Analysis Flexural Toppling	
Slope Dip 75	
Slope Dip Direction 120	
Friction Angle 35°	
Lateral Limits 30°	
	Critical Total %
Flexural Toppling (All)	24 268 8.96%
Plot Mode Pole Vectors	
Vector Count 268 (268 Entries)	
Hemisphere Lower	
Projection Equal Area	

Figure 16-25 Kinematic analysis for the slope T4 showing 9% of probability for toppling rupture

Pre-Feasibility Study

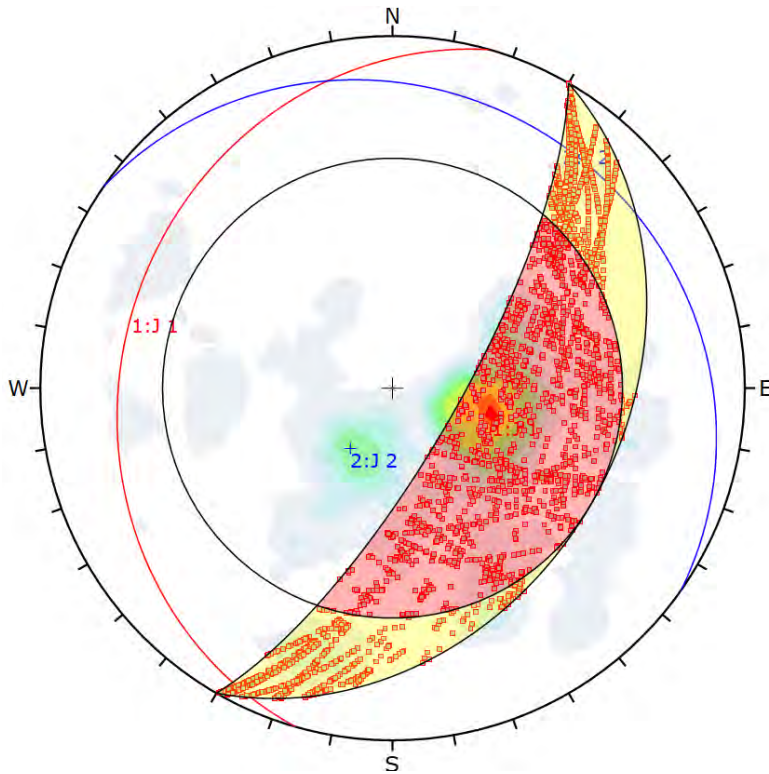

Symbol	Feature
■	Critical Intersection

Color	Density Concentrations
0.00 - 1.20	
1.20 - 2.40	
2.40 - 3.60	
3.60 - 4.80	
4.80 - 6.00	
6.00 - 7.20	
7.20 - 8.40	
8.40 - 9.60	
9.60 - 10.80	
10.80 - 12.00	

Maximum Density	11.94%
Contour Data	Pole Vectors
Contour Distribution	Schmidt
Counting Circle Size	1.0%

Kinematic Analysis	Wedge Sliding
Slope Dip	75
Slope Dip Direction	120
Friction Angle	35°

	Critical	Total	%
Wedge Sliding	3252	35775	9.09%

Plot Mode	Pole Vectors
Vector Count	268 (268 Entries)
Intersection Mode	Grid Data Planes
Intersections Count	35775
Hemisphere	Lower
Projection	Equal Area

Figure 16-26 Kinematic analysis for the slope T4 showing 9% of probability for wedge rupture

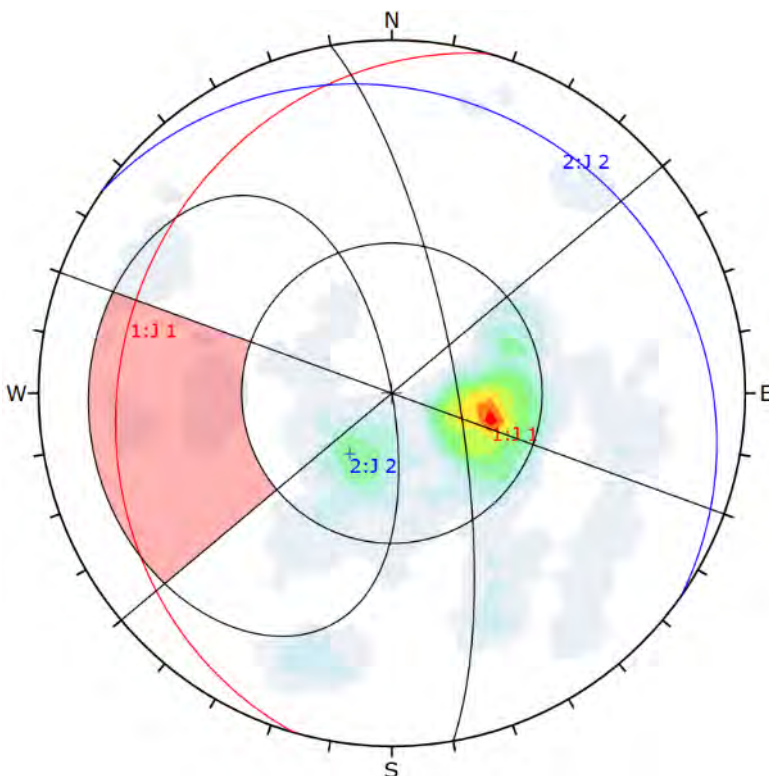

Color	Density Concentrations
0.00 - 1.20	
1.20 - 2.40	
2.40 - 3.60	
3.60 - 4.80	
4.80 - 6.00	
6.00 - 7.20	
7.20 - 8.40	
8.40 - 9.60	
9.60 - 10.80	
10.80 - 12.00	

Maximum Density	11.94%
Contour Data	Pole Vectors
Contour Distribution	Schmidt
Counting Circle Size	1.0%

Kinematic Analysis	Planar Sliding
Slope Dip	75
Slope Dip Direction	80
Friction Angle	35°
Lateral Limits	30°

	Critical	Total	%
Planar Sliding (All)	23	268	8.58%

Plot Mode	Pole Vectors
Vector Count	268 (268 Entries)
Hemisphere	Lower
Projection	Equal Area

Figure 16-27 Kinematic analysis for the slope T5 showing 9% of probability for planar rupture

Pre-Feasibility Study

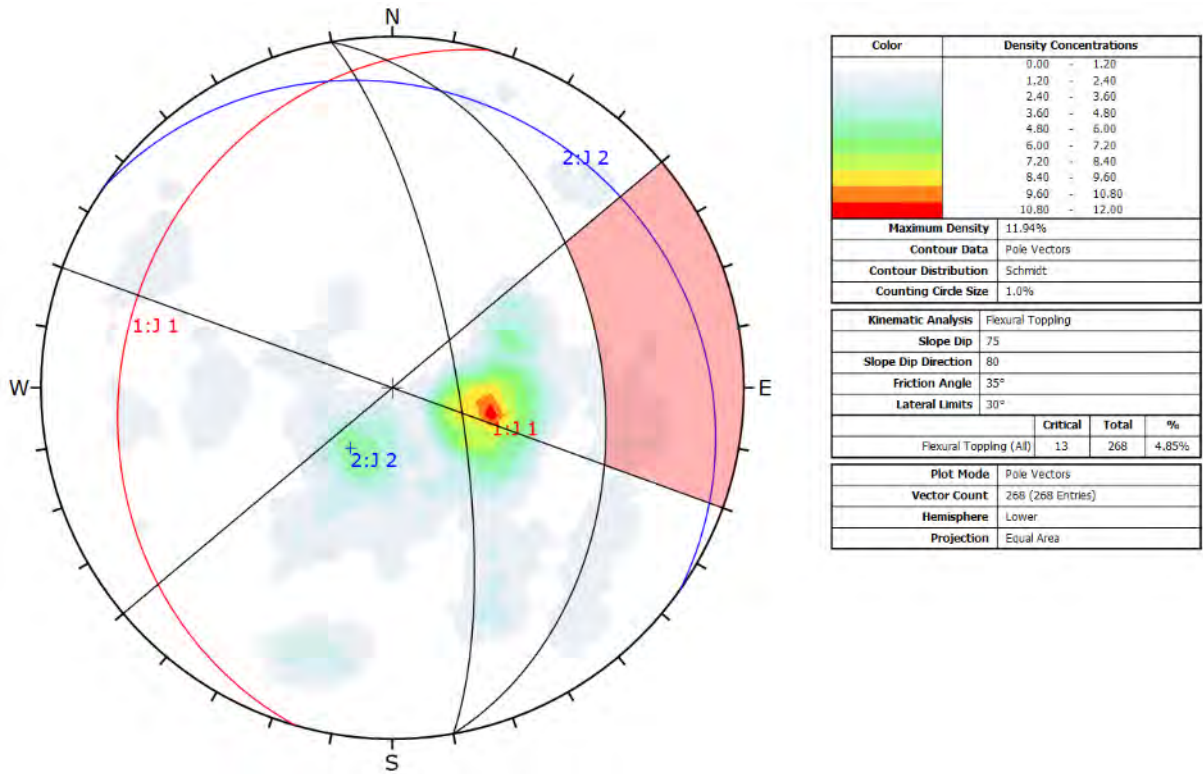

Figure 16-28 Kinematic analysis for the slope T5 showing 5% of probability for toppling rupture

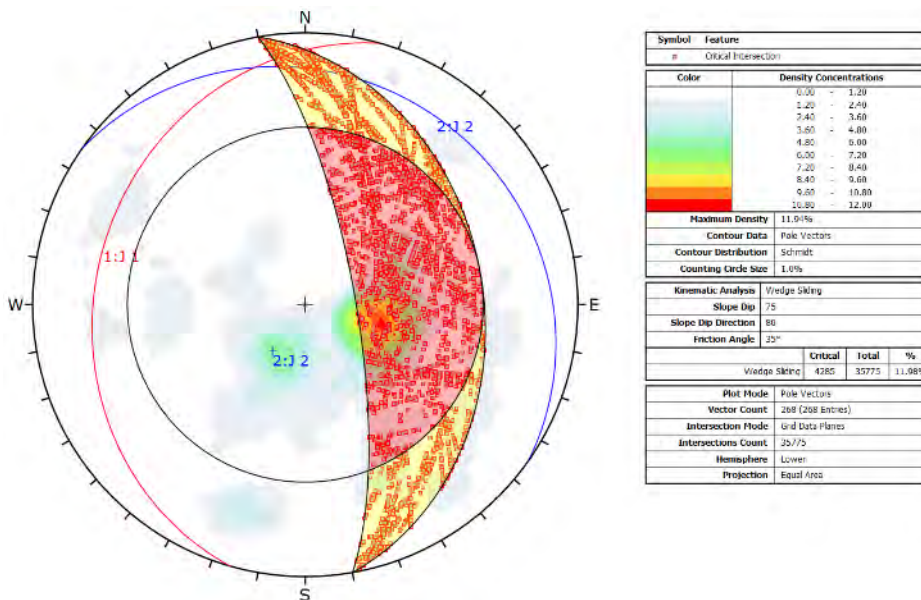

Figure 16-29 Kinematic analysis for the slope T5 showing 5% of probability for wedge rupture

Pre-Feasibility Study

Limit-equilibrium slope stability analysis were performed for Pit 2 on sections 03 and 04 at the highest height of the slopes, adopting the parameters obtained in RocLab software.

The results of the analysis are shown in Figure 16-30 and Figure 16-31.

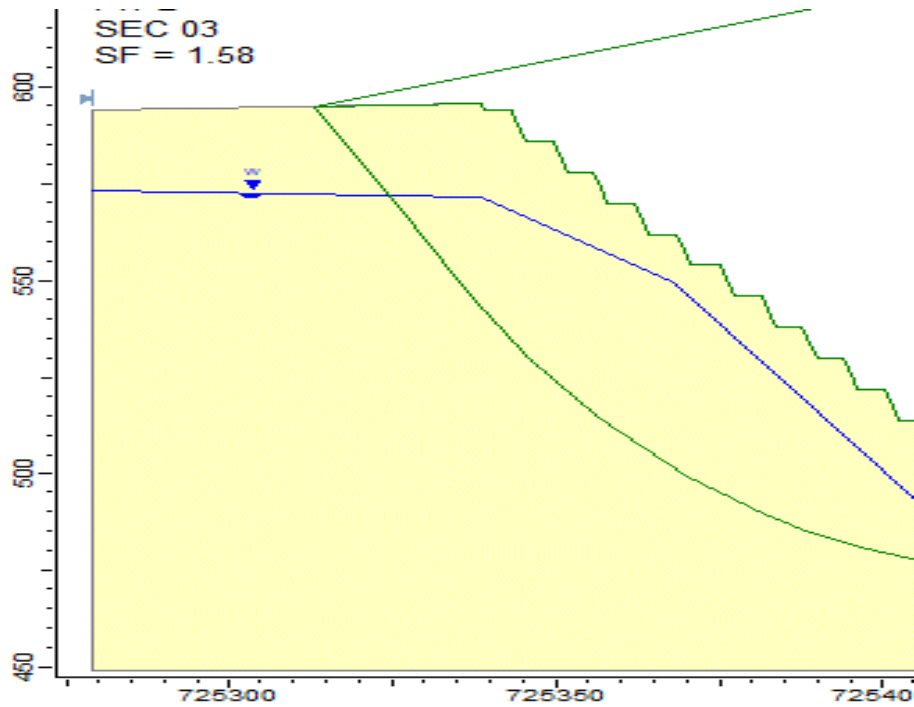

Figure 16-30 Limit-equilibrium analysis results for Section 03 with FS (security factor) = 1.58

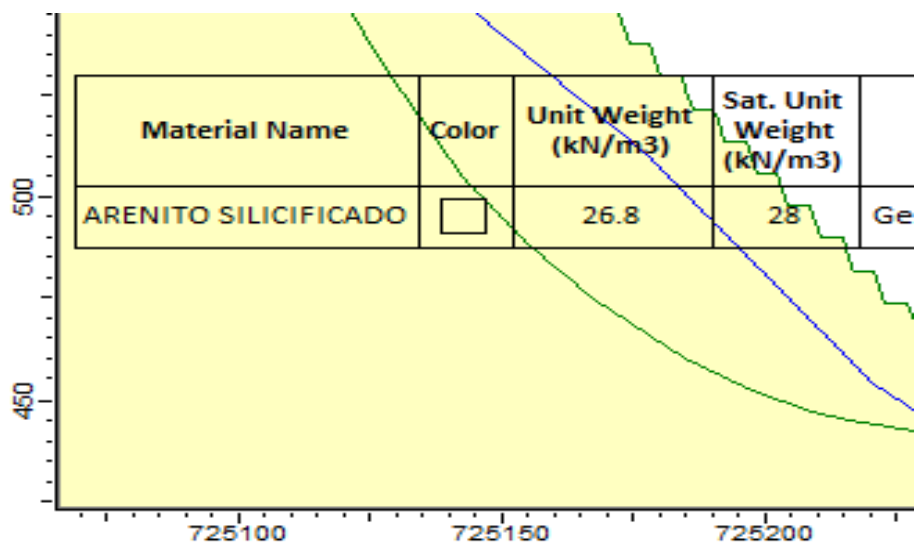

Figure 16-31 Limit-equilibrium analysis results for Section 04 with FS (security factor) = 1.62

Pre-Feasibility Study

16.1.5 Kinematic and Stability Analysis – Pit 3

Kinematic and slope stability analysis were performed for Pit 1, on slopes T6 (75/315), T7 (75/000) by the sections 05 to 08 (Figure 16-32).

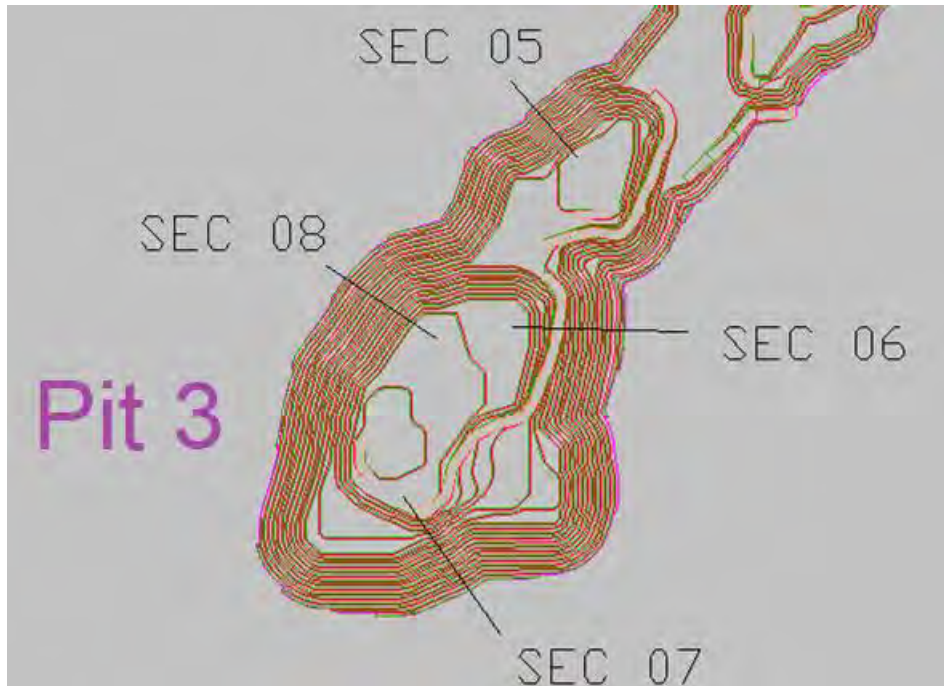

Figure 16-32 Pit 3 sectors

Kinematic analyses were performed to evaluate planar, toppling and wedge ruptures. The friction angle adopted was obtained from RocLab, Cohesion of 400 MPa and friction angle of 35°.

Figure 16-33 to Figure 16-38 show the analysis for the sectors and the respective percentages of occurrences.

Pre-Feasibility Study

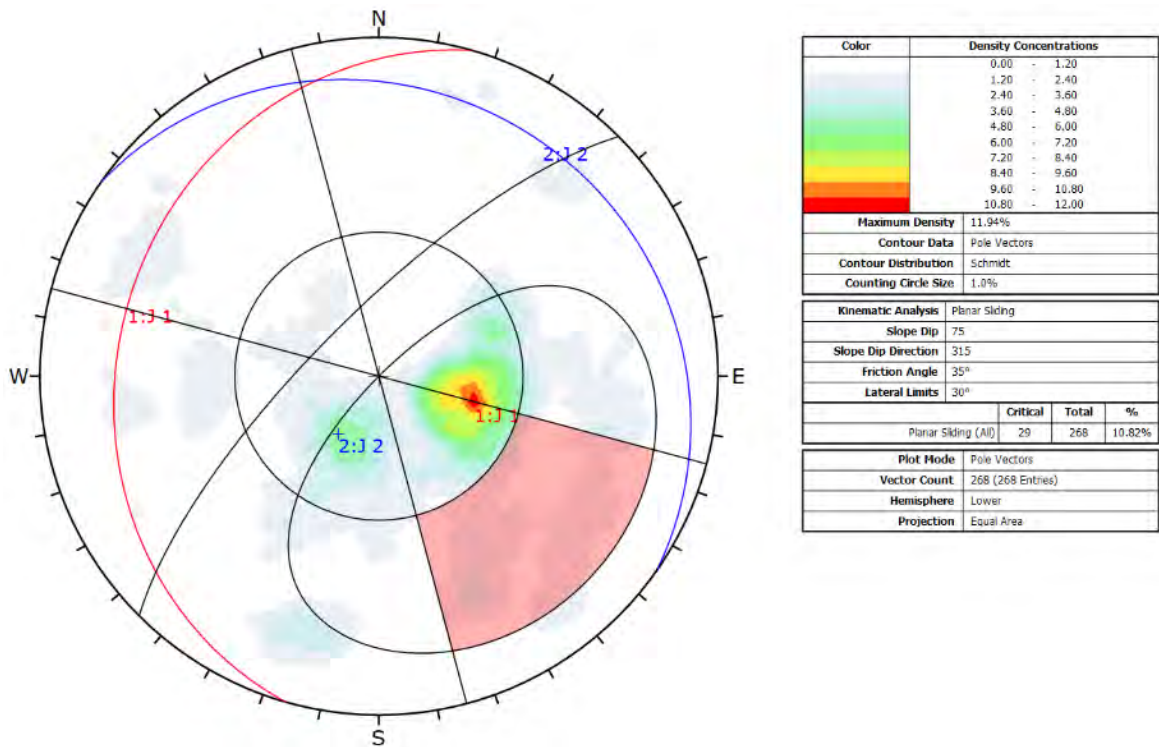

Figure 16-33 Kinematic analysis for the slope T6 showing 11% of probability for planar rupture

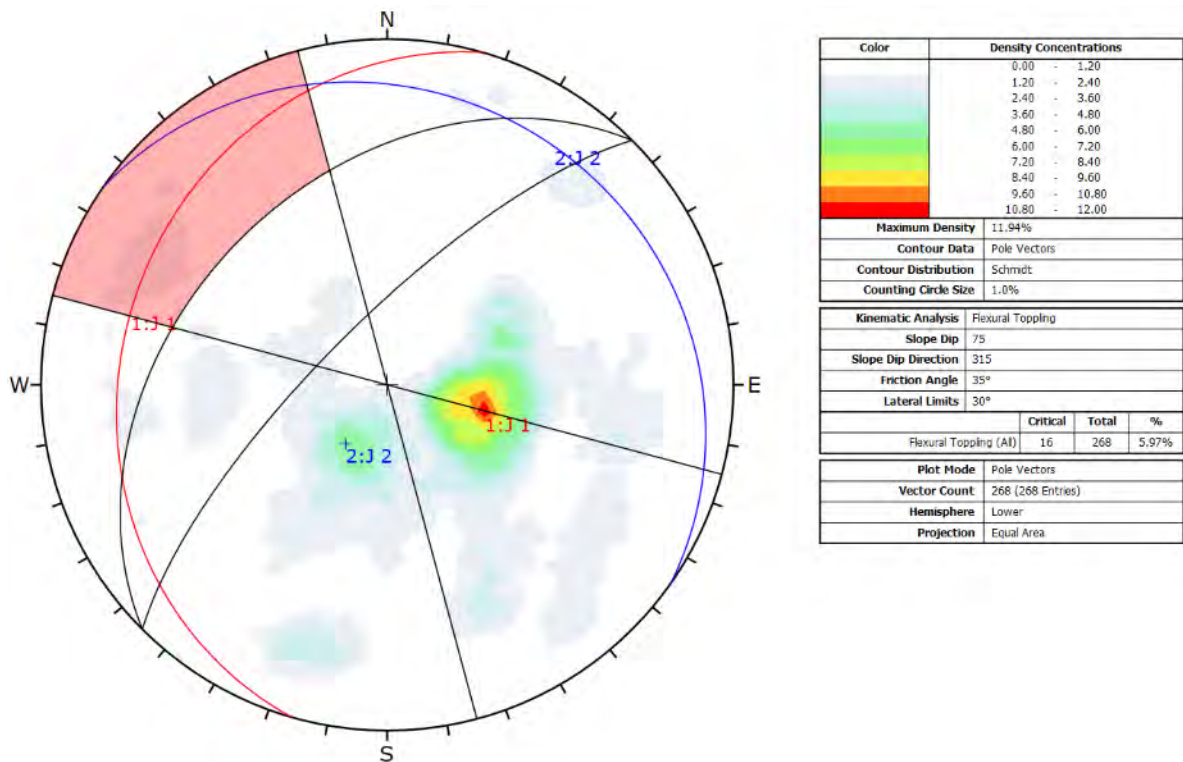
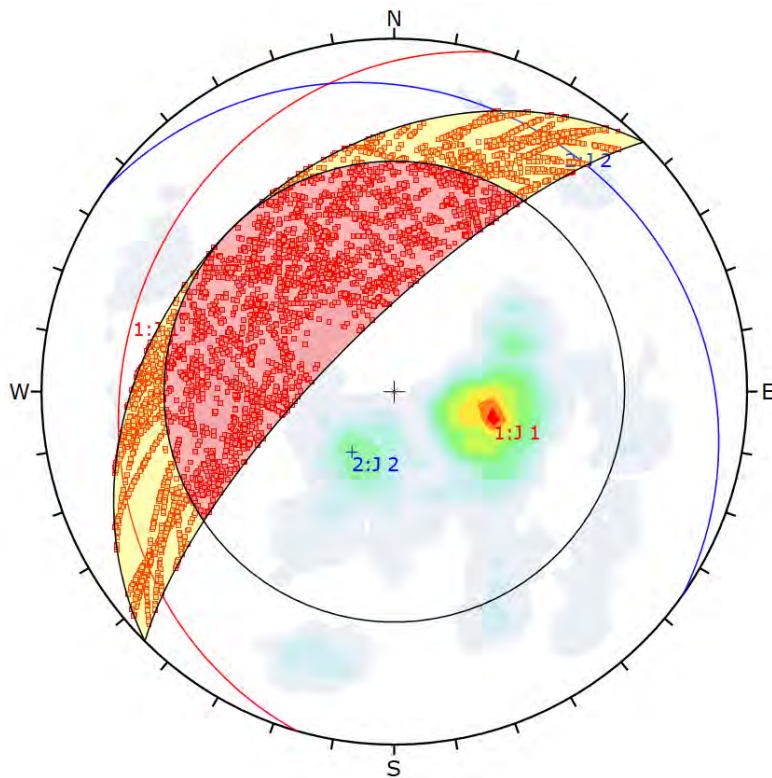

Figure 16-34 Kinematic analysis for the slope T6 showing 5% of probability for toppling rupture

Pre-Feasibility Study



Symbol	Feature
■	Critical Intersection

Color	Density Concentrations
0.00	- 1.20
1.20	- 2.40
2.40	- 3.60
3.60	- 4.80
4.80	- 6.00
6.00	- 7.20
7.20	- 8.40
8.40	- 9.60
9.60	- 10.80
10.80	- 12.00

Maximum Density	11.94%
Contour Data	Pole Vectors
Contour Distribution	Schmidt
Counting Circle Size	1.0%

Kinematic Analysis		Wedge Sliding		
Slope Dip	75			
Slope Dip Direction	315			
Friction Angle	35°			
		Critical	Total	%
Wedge Sliding		5439	35775	15.20%

Plot Mode	Pole Vectors
Vector Count	268 (268 Entries)
Intersection Mode	Grid Data Planes
Intersections Count	35775
Hemisphere	Lower
Projection	Equal Area

Figure 16-35 Kinematic analysis for the slope T6 showing 15% of probability for wedge rupture

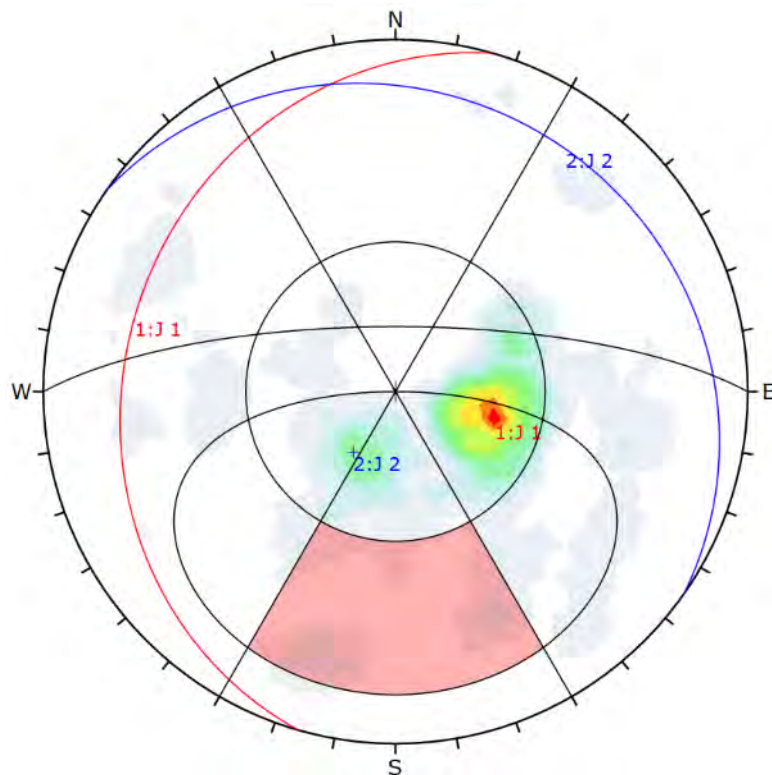

Color	Density Concentrations
0.00	- 1.20
1.20	- 2.40
2.40	- 3.60
3.60	- 4.80
4.80	- 6.00
6.00	- 7.20
7.20	- 8.40
8.40	- 9.60
9.60	- 10.80
10.80	- 12.00

Maximum Density	11.94%
Contour Data	Pole Vectors
Contour Distribution	Schmidt
Counting Circle Size	1.0%

Kinematic Analysis		Planar Sliding		
Slope Dip	75			
Slope Dip Direction	0			
Friction Angle	35°			
Lateral Limits	30°			
		Critical	Total	%
Planar Sliding (All)		31	268	11.57%

Plot Mode	Pole Vectors
Vector Count	268 (268 Entries)
Hemisphere	Lower
Projection	Equal Area

Figure 16-36 Kinematic analysis for the slope T7 showing 12% of probability for planar rupture

Pre-Feasibility Study

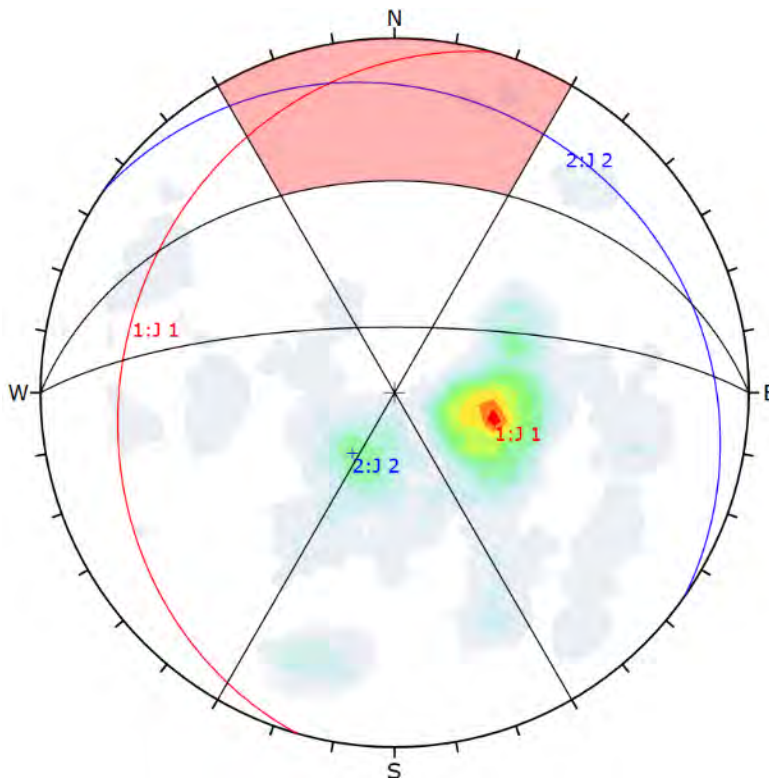

Color	Density Concentrations
	0.00 - 1.20
	1.20 - 2.40
	2.40 - 3.60
	3.60 - 4.80
	4.80 - 6.00
	6.00 - 7.20
	7.20 - 8.40
	8.40 - 9.60
	9.60 - 10.80
	10.80 - 12.00

Maximum Density	11.94%
Contour Data	Pole Vectors
Contour Distribution	Schmidt
Counting Circle Size	1.0%

Kinematic Analysis	Flexural Topping
Slope Dip	75
Slope Dip Direction	0
Friction Angle	35°
Lateral Limits	30°

	Critical	Total	%
Flexural Topping (All)	10	268	3.73%

Plot Mode	Pole Vectors
Vector Count	268 (268 Entries)
Hemisphere	Lower
Projection	Equal Area

Figure 16-37 Kinematic analysis for the slope T7 showing 4% of probability for toppling rupture

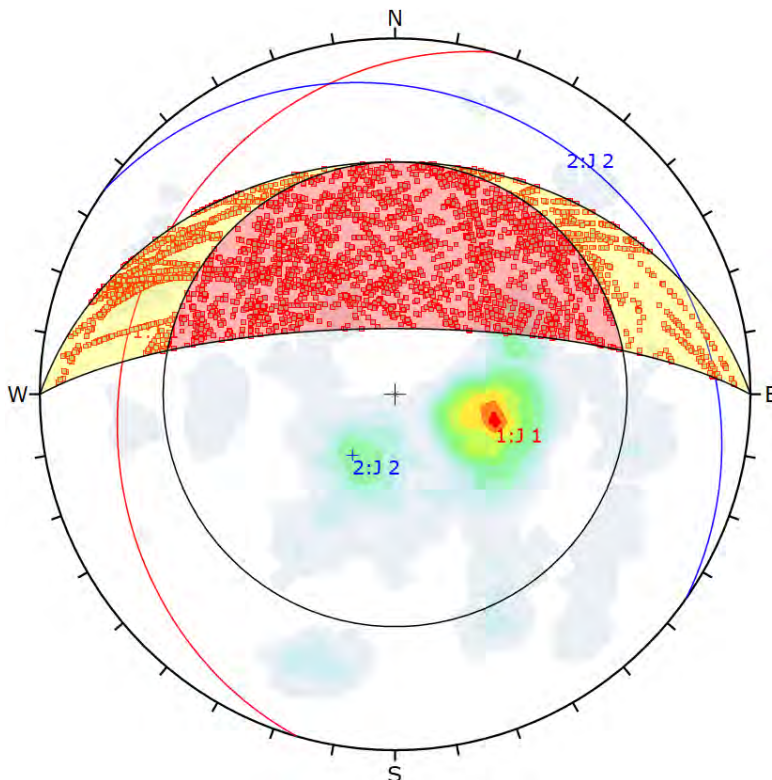

Symbol	Feature
■	Critical Intersection

Color	Density Concentrations
	0.00 - 1.20
	1.20 - 2.40
	2.40 - 3.60
	3.60 - 4.80
	4.80 - 6.00
	6.00 - 7.20
	7.20 - 8.40
	8.40 - 9.60
	9.60 - 10.80
	10.80 - 12.00

Maximum Density	11.94%
Contour Data	Pole Vectors
Contour Distribution	Schmidt
Counting Circle Size	1.0%

Kinematic Analysis	Wedge Sliding
Slope Dip	75
Slope Dip Direction	0
Friction Angle	35°

	Critical	Total	%
Wedge Sliding	5400	35775	15.09%

Plot Mode	Pole Vectors
Vector Count	268 (268 Entries)
Intersection Mode	Grid Data Planes
Intersections Count	35775
Hemisphere	Lower
Projection	Equal Area

Figure 16-38 Kinematic analysis for the slope T7 showing 15% of probability for wedge rupture

Pre-Feasibility Study

Limit-equilibrium slope stability analysis were performed for Pit 3 on sections 05 to 08 at the highest height of the slopes, adopting the parameters obtained in RocLab software.

The results of the analysis are shown in Figure 16-39 to Figure 16-42.

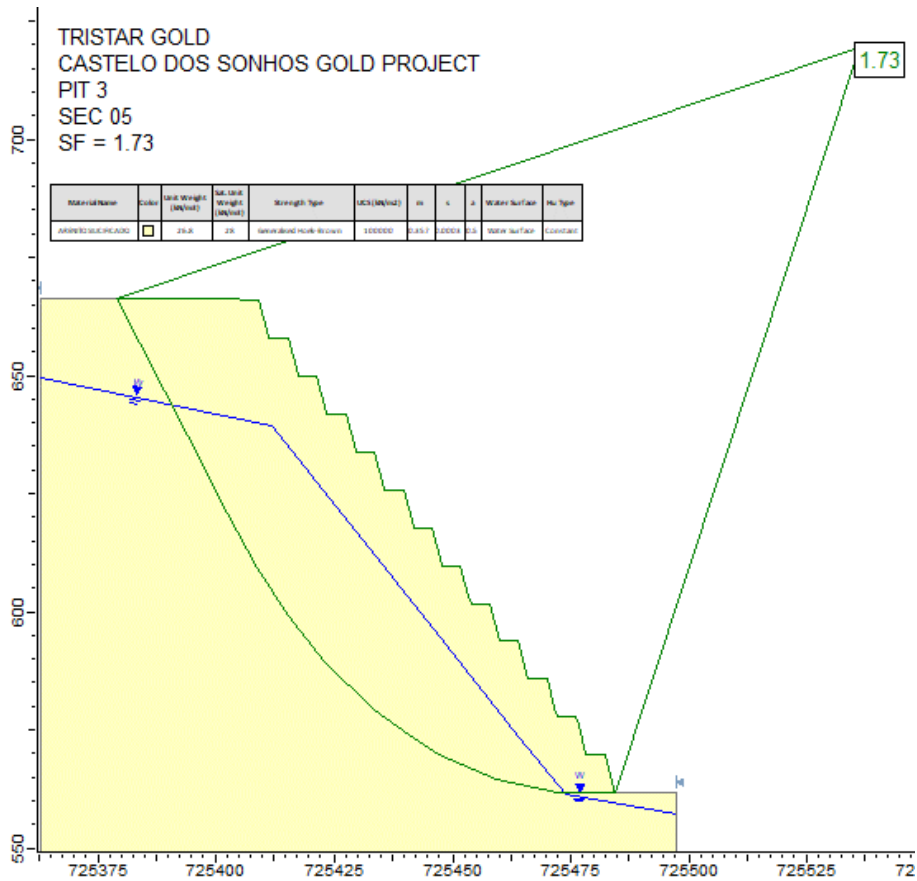

Figure 16-39 Limit-equilibrium analysis results for Section 05 with FS (safety factor) = 1.73

Pre-Feasibility Study

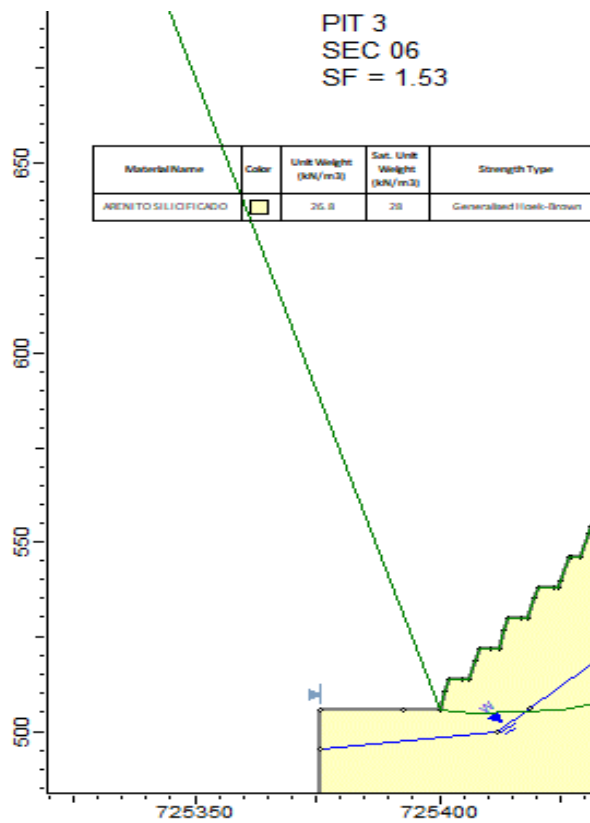

Figure 16-40 Limit-equilibrium analysis results for Section 06 with FS (safety factor) = 1.53

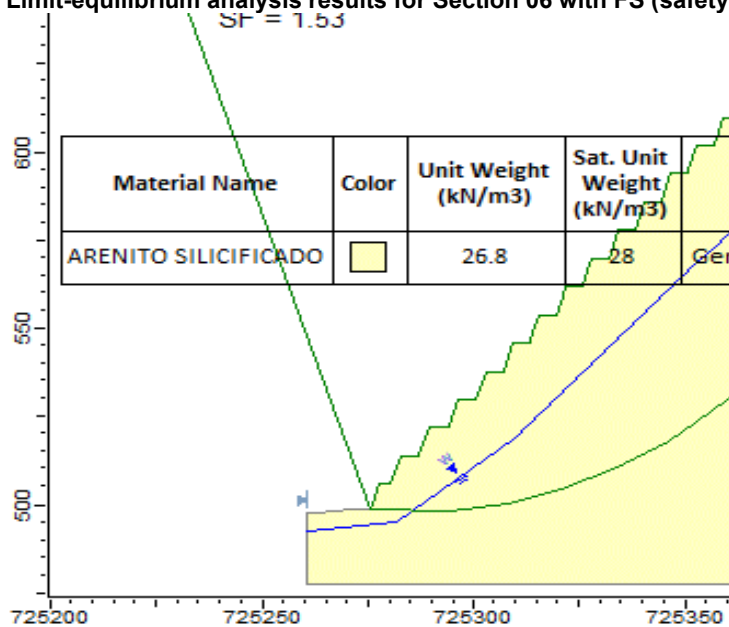

Figure 16-41 Limit-equilibrium analysis results for Section 07 with FS (safety factor) = 1.53

Pre-Feasibility Study

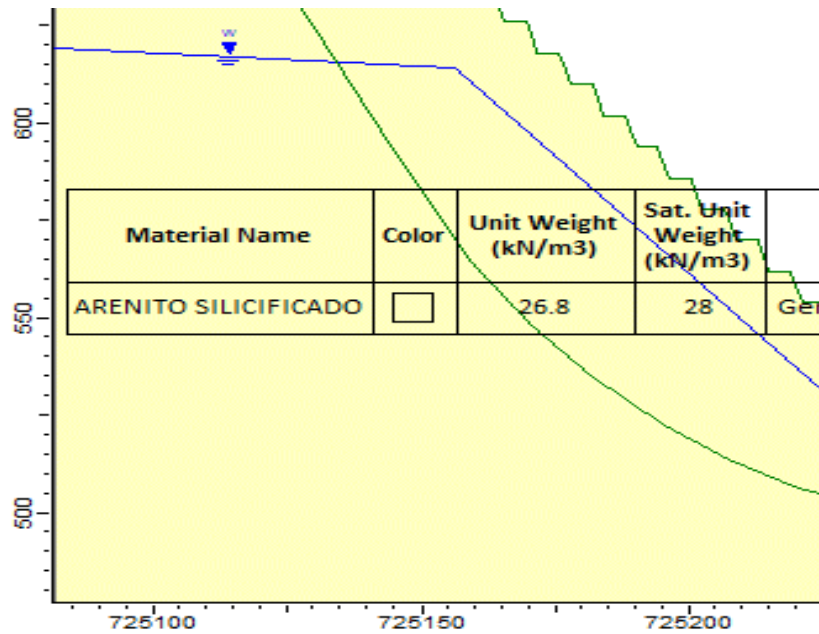

Figure 16-42 Limit-equilibrium analysis results for Section 08 with FS (safety factor) = 1.48

16.1.6 Stability Analysis – Pit 4

Kinematic and slope stability analysis were performed for Pit 4, by the sections 09 to 11 (Figure 16-43).

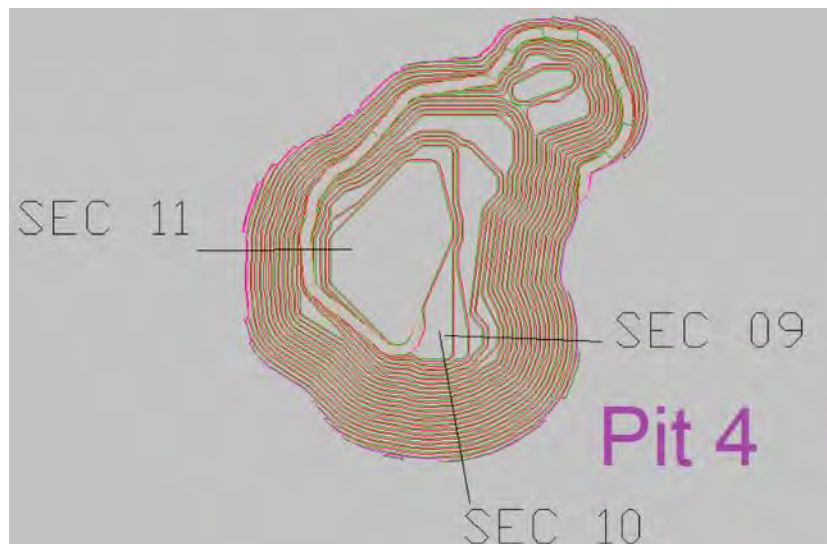

Figure 16-43 Pit 4 sectors

Limit-equilibrium slope stability analysis were performed for Pit 2 on sections 03 and 04 at the highest height of the slopes, adopting the parameters obtained in RocLab software.

The results of the analysis are shown in Figure 16-44 to Figure 16-46.

Pre-Feasibility Study

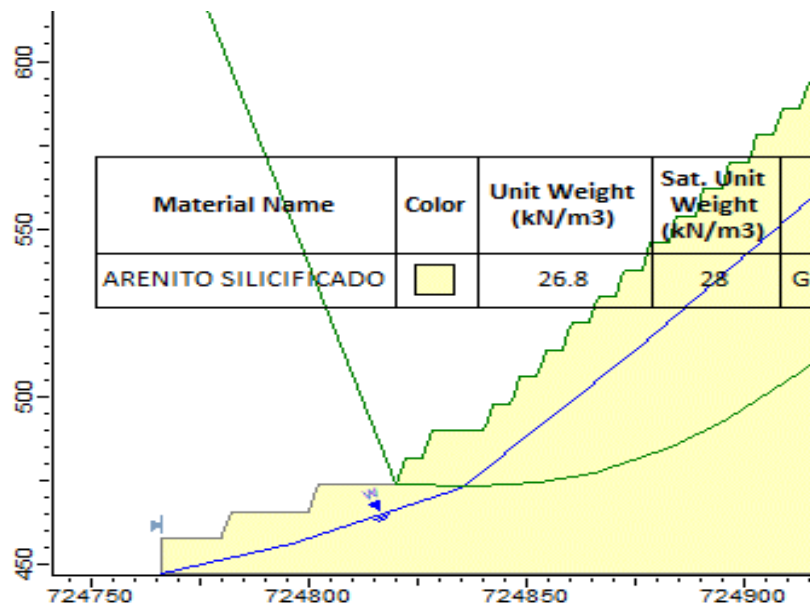

Figure 16-44 Limit-equilibrium analysis results for Section 09 with FS (safety factor) = 1.54

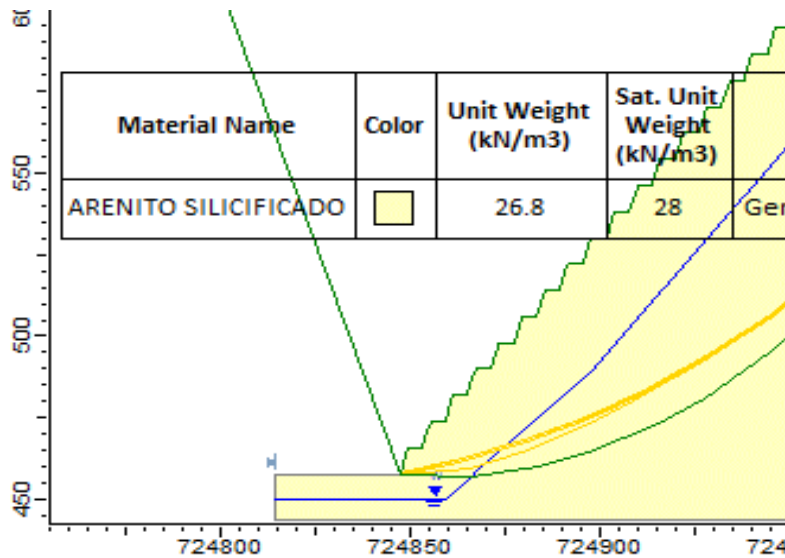

Figure 16-45 Limit-equilibrium analysis results for Section 10 with FS (safety factor) = 1.40

Pre-Feasibility Study

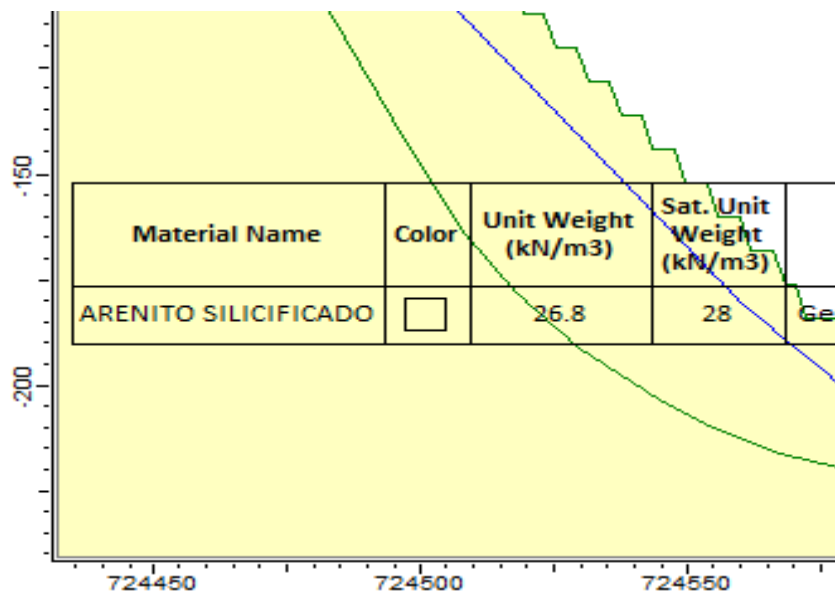

Figure 16-46 Limit-equilibrium analysis results for Section 11 with FS (safety factor) = 1.48

16.1.7 Waste Deposition Stability Analysis

This subsection presents the study of the conceptual design for the waste piles (PDE) for Esperança Center - EC, Esperança East - EE, Esperança South Northern Dump - NORTH and Esperança South Southern Dump – SOUTH, for the Castelo de Sonhos Project.

The project follows the guidelines contained in Brazilian national standards (ABNT NBR 13029 of July 2017, Mining - Preparation and presentation of a project for disposal of waste dump and ABNT NBR 13028 of November 2017, Mining - Preparation and presentation of a dam project for disposal of tailings, sediment containment and water reservation - Requirements, in mining, and other related norms).

Geometric Parameters for waste dumps are presented at Table 16-7. The layout for the waste dumps is presented in Section 18.

Table 16-7 Waste Pile Geometric Parameters.

PDE EE	
Maximum height	72 m
Minimum and maximum elevation	278/350 m
Bench height	20 m
Berm Width	10 m
Slope Angle	1V:1.8H – 29°
Longitudinal inclination	1%
Transversal Inclination	5%
Area	16,2ha
Volume	5.57 Mm ³

Pre-Feasibility Study

PDE EC	
Maximum elevation	188 m
Minimum and maximum elevation	402/590 m
Bench height	20 m
Berm Width	10 m
Slope Angle	1V:1,8H – 29°
Longitudinal inclination	1%
Transversal Inclination	5%
Area	72,10ha
Volume	35.95 Mm ³
PDE NORTH	
Maximum elevation	223 m
Minimum and maximum elevation	327/550 m
Bench height	20 m
Berm Width	10 m
Slope Angle	1V:1,8H – 29°
Longitudinal inclination	1%
Transversal Inclination	5%
Area	46,12ha
Volume	23.63 Mm ³
PDE SOUTH	
Maximum elevation	223 m
Minimum and maximum elevation	535/770 m
Benches eights	20 m
Berm Width	10 m
Slope Angle	1V:1,8H – 29°
Longitudinal inclination	1%
Transversal Inclination	5%
Area	125,57ha
Volume	96.66 Mm ³

Stability Analysis

Stability analysis section was selected crossing the maximum heights of the waste piles, considering the hypothesis of circular rupture, since it is a granular material. The Slide software was used, the Simplified Bishop/Spencer/GLE method, being adopted as resistance parameters those used in waste dumps of similar materials (Table 16-8).

Pre-Feasibility Study

Table 16-8 Rock Mass Parameters.

Material	τ (kN/m ³)	Rock mass parameters	
		C' (kN/m ²)	ϕ' (°)
Waste	19	1	40
Basement Solo Residual	20	5	35

Water level was adopted close to the base of the pile, simulating the loss of internal drainage. The results obtained are summarized in Table 16-9 and in Figure 16-47 to Figure 16-50. Results present a safety factor ranging from 1.58 to 1.72.

Table 16-9 Results of safety factors.

PDE/Section	Safety Factor
EC/SEC BB	1.58
EE/SEC AA	1.52
NORTH/SEC AA	1.62
SOUTH/SEC BB	1.72

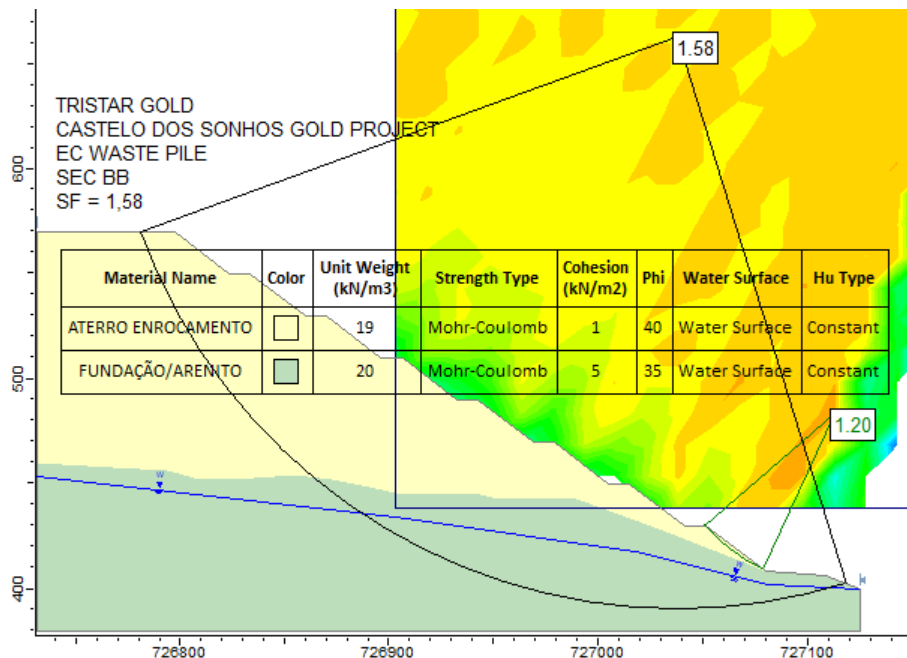

Figure 16-47 Stability analysis - Section BB / PDE EC

Pre-Feasibility Study

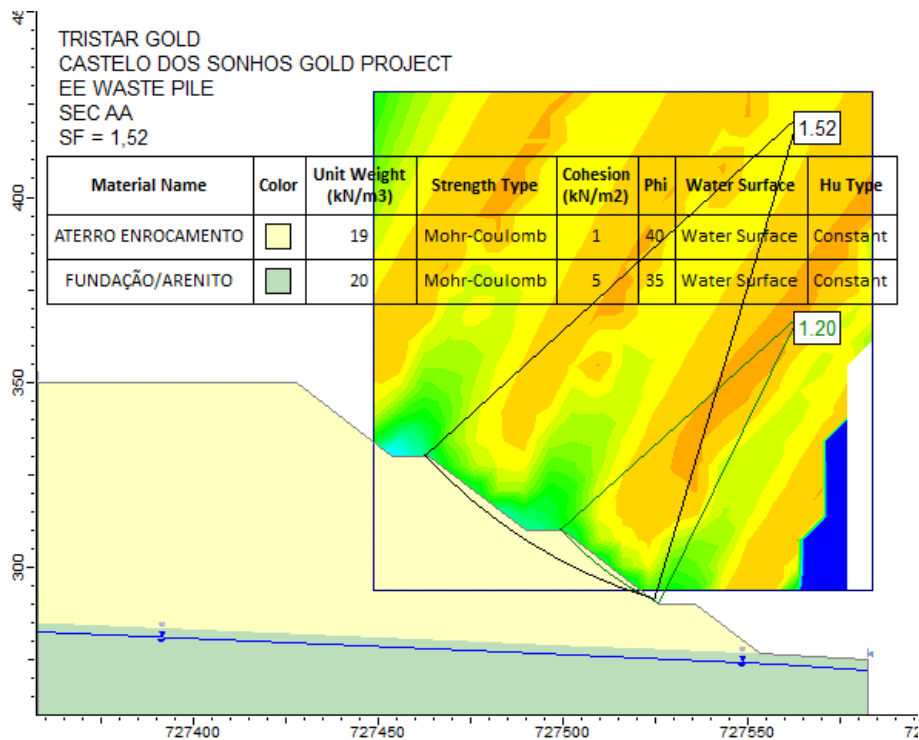

Figure 16-48 Stability analysis - Section AA / PDE EE

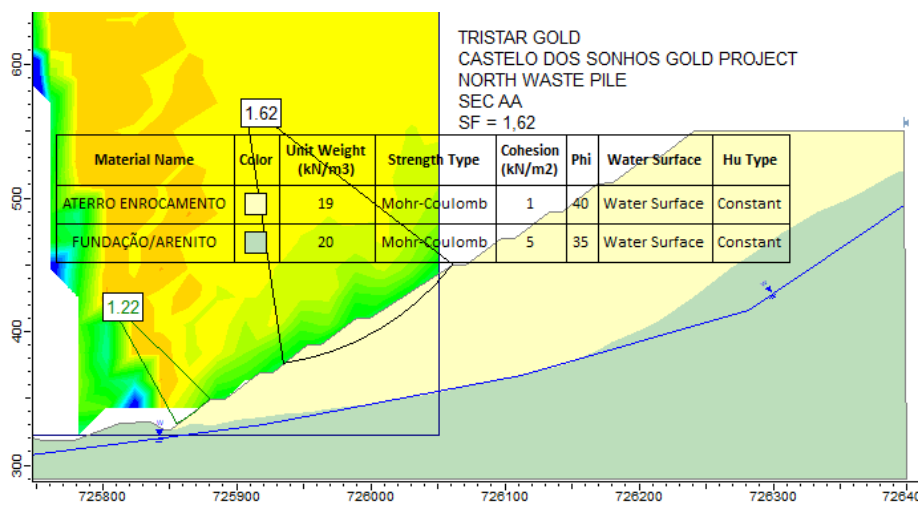

Figure 16-49 Stability analysis - Section AA / PDE NORTH

Pre-Feasibility Study

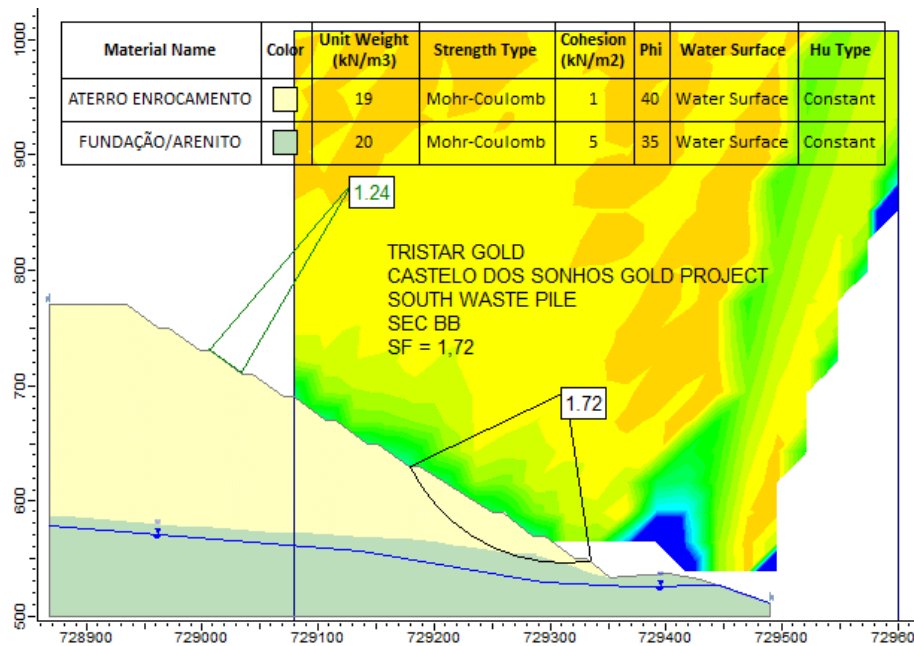

Figure 16-50 Stability analysis - Section BB.

16.1.7.1 Sumps

Sumps must be implemented on the drainage system to contain the generated fines during the construction of the pile. The accumulated sediment must be frequently removed during the pile management.

16.1.8 Final Considerations Based on Slope Stability Analysis Results

The pit slope design parameters, including slope angles, are in accordance with stability parameters for open pits, based on the results of kinematic analysis and limit-equilibrium stability analysis (Table 16-10).

Table 16-10 Summary results for limit-equilibrium slope stability analysis

Section ID	Pit	Safety Factor
SEC 01	01	1.62
SEC 02	01	1.68
SEC 03	02	1.58
SEC 04	02	1.51
SEC 05	03	1.73
SEC 06	03	1.53
SEC 07	03	1.53
SEC 08	03	1.48
SEC 09	04	1.54
SEC 10	04	1.40
SEC 11	04	1.48

Pre-Feasibility Study**16.2 Pit Optimization**

The determination of the optimal pit was based on:

- The definition of the economic and geometric parameters to produce the economic function and calculate the cut-off grade.
- A calculation of the nested optimal pits using Geovia Whittle 4.7 software.

The determination of the geometry of the mathematical or optimal pits was performed through the generation of an optimal sequence of pushbacks or nested pits, which correspond to increments in the geometry of the pit, resulting from the repeated use of the three-dimensional Lerchs & Grossman algorithm for different values of blocks that are obtained by varying the price of the product with a revenue factor.

This sequence of pit expansions, or pushbacks, is the basis of open pit mine planning when using Whittle software, which projects the evolution of the geometry of the pit over time. The evolution of the mining process over time can be simulated with two criteria: the maximizing NPV approach or the maintaining production approach. The first attempts to maximize the operation's financial returns based on a sequence of pushbacks that optimize the cash flow; the latter aims to maintain the feed to the processing plant at a constant level.

The sequence of optimal pits was obtained by varying the revenue factor from 50% to 200% with respect to the product's selling price. To determine the evolution of the pits over time, an annual production scale of 3.65Mtpa of ROM was established, at an Annual Discount Rate of 10% Table 16-11 presents the first pass parameters for pit optimization, and at Figure 16-51 to Figure 16-52 are shown the evolution of optimization pushbacks resulting graph with the chosen pit highlighted. Table 16-12 to Table 16-14 present the nested pit optimization results. Table 16-15 presents the pit optimization results of the Castelo de Sonhos project from Whittle.

Pre-Feasibility Study

Table 16-11 Pit Optimization First Pass Parameters

	Item		Unit	Value
	Revenue	Economic Parameters	Selling Price	US\$/oz
Weighted Average Cost of Capital (WACC)			%	10
ROM		Density	g/cm ³	Block Model
		Grades	g/t	Block Model
Mine		Mining Recovery	%	-
		Dilution		-
Block Model		Block size	Units	Values
		X	m	20
		Y		20
		Z		4
Slope Angle	Ore	°	55	
	Waste		55	
Process	Metallurgical Recovery	%	98	
Costs	Mining	US\$/t mined	2.17	
	Process	US\$/t ROM	9.99	
	G&A	US\$/oz	13.6	

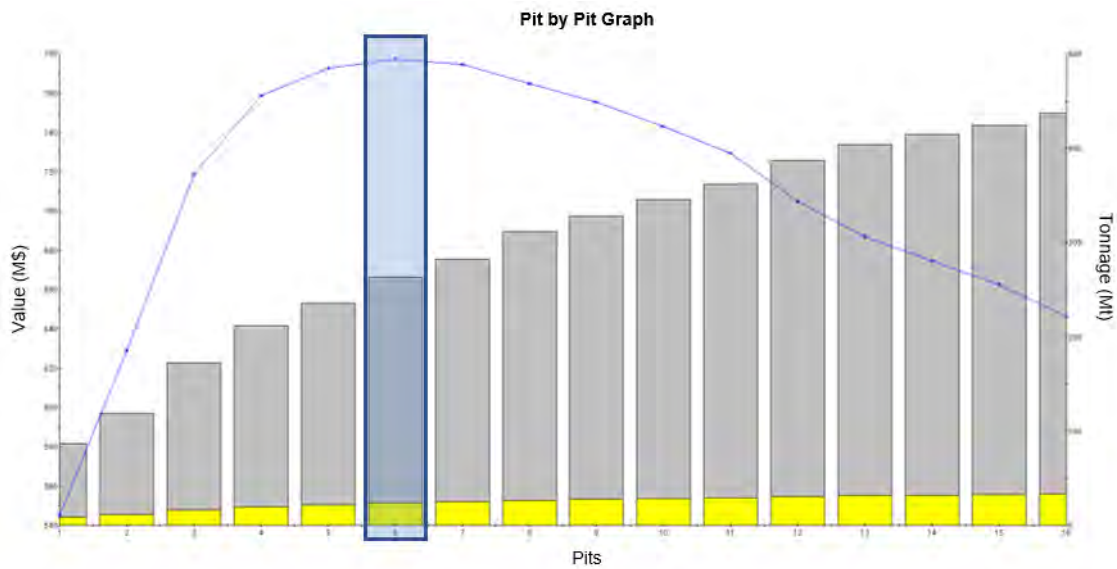

Figure 16-51 Pit by Pit Graph for Esperança South

* Bars: Yellow – ROM Tonnage, Gray – Waste Tonnage.

* Line: Discounted open pit value for Best Case.

* Selected pit shell: 6.

Pre-Feasibility Study

Table 16-12 Nested pits results for Esperança South

ES Pit	Revenue Factor	Ore Mt	Waste Mt	Strip Ratio	Au (g/t)	Au (koz)
1	0.5	8.17	78.50	9.61	2.05	538.7
2	0.6	11.38	107.82	9.47	1.82	664.3
3	0.7	16.42	156.04	9.50	1.58	834.5
4	0.8	19.73	192.08	9.73	1.48	940.2
5	0.9	21.66	214.27	9.89	1.43	997.2
6	1	23.82	239.54	10.06	1.38	1053.8
7	1.1	25.14	257.26	10.23	1.35	1088.8
8	1.2	26.58	285.20	10.73	1.33	1134.1
9	1.3	27.66	300.75	10.87	1.30	1158.6
10	1.4	28.65	316.99	11.07	1.28	1182.6
11	1.5	29.50	332.41	11.27	1.27	1201.9
12	1.6	30.81	356.72	11.58	1.24	1231.3
13	1.7	31.76	372.30	11.72	1.22	1250.0
14	1.8	32.27	382.50	11.85	1.22	1260.4
15	1.9	32.68	392.14	12.00	1.21	1269.2
16	2	33.27	404.44	12.16	1.20	1281.4

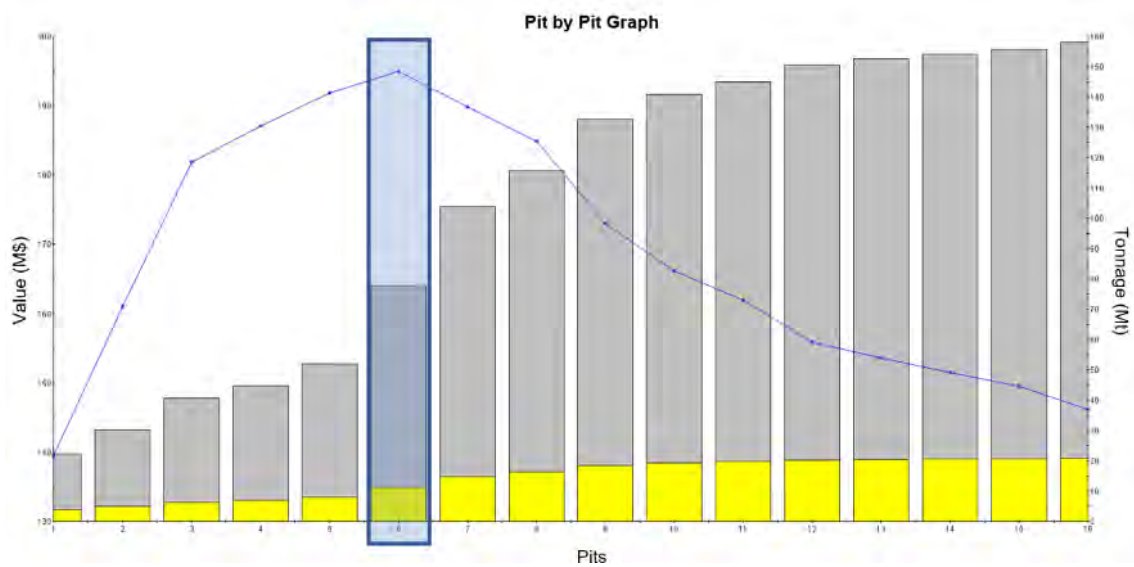

Figure 16-52 Pit by Pit Graph for Esperança Center

* Bars: Yellow – ROM Tonnage, Gray – Waste Tonnage.

* Line: Discounted open pit value for Best Case.

* Selected pit shell: 6.

Pre-Feasibility Study

Table 16-13 Nested pits results for Esperança Center

EC Pit	Revenue Factor	Ore Mt	Waste Mt	Strip Ratio	Au (g/t)	Au (koz)
1	0.5	2.39	20.03	8.39	1.735	133.1
2	0.6	4.21	26.02	6.18	1.296	175.4
3	0.7	6.18	34.37	5.56	1.106	219.7
4	0.8	7.04	37.68	5.35	1.04	235.5
5	0.9	8.05	44.00	5.47	0.989	255.9
6	1	11.39	66.39	5.83	0.866	317.1
7	1.1	14.86	89.06	5.99	0.784	374.7
8	1.2	16.31	99.34	6.09	0.758	397.5
9	1.3	18.47	114.22	6.18	0.722	428.7
10	1.4	19.39	121.42	6.26	0.709	442.0
11	1.5	19.81	125.08	6.31	0.703	447.8
12	1.6	20.32	130.16	6.41	0.697	455.3
13	1.7	20.47	132.03	6.45	0.695	457.5
14	1.8	20.60	133.47	6.48	0.694	459.7
15	1.9	20.72	134.86	6.51	0.692	460.9
16	2	20.85	137.26	6.58	0.691	463.2

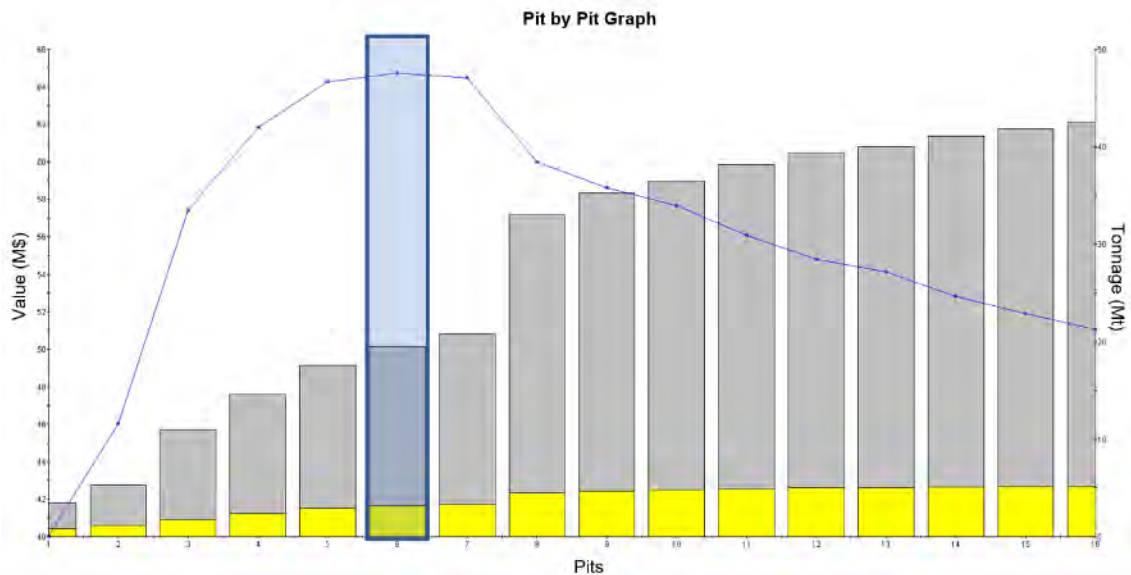

Figure 16-53 Pit by Pit Graph for Esperança East

* Bars: Yellow – ROM Tonnage, Gray – Waste Tonnage.

* Line: Discounted open pit value for Best Case.

* Selected pit shell: 6.

Pre-Feasibility Study
Table 16-14 Nested pits results for Esperança East

EE Pit	Revenue Factor	Ore Mt	Waste Mt	Strip Ratio	Au (g/t)	Au (koz)
1	0.5	0.83	2.62	3.15	1.384	37.0
2	0.6	1.11	4.22	3.79	1.274	45.6
3	0.7	1.77	9.25	5.23	1.156	65.7
4	0.8	2.40	12.20	5.09	1.012	78.0
5	0.9	2.94	14.65	4.98	0.927	87.6
6	1	3.16	16.34	5.17	0.906	92.1
7	1.1	3.31	17.48	5.29	0.891	94.7
8	1.2	4.47	28.57	6.38	0.814	117.1
9	1.3	4.68	30.56	6.54	0.803	120.7
10	1.4	4.79	31.67	6.61	0.797	122.7
11	1.5	4.92	33.24	6.75	0.789	124.9
12	1.6	5.01	34.39	6.86	0.785	126.5
13	1.7	5.05	34.95	6.92	0.783	127.2
14	1.8	5.10	36.03	7.06	0.782	128.3
15	1.9	5.14	36.72	7.14	0.78	129.0
16	2	5.18	37.34	7.21	0.778	129.5

Table 16-15 Pit Optimization Results Summary

Pit Optimization Results Summary						
Area	Rock (Mt)	ROM (Mt)	Waste (Mt)	SR	Au (g/t)	Moz
Esp. South	263.36	23.82	239.54	10.1	1.38	1.05
Esp. Center	77.78	11.39	66.39	5.83	0.87	0.32
Esp. East	19.50	3.16	16.34	5.17	0.91	0.09
Total	360.64	38.37	322.26	8.40	1.19	1.46

Block Model: 20m x 20m x 4m.

16.3 Mining Dilution and Losses

In order to report Mineral Reserves an estimate of the modifying factor of dilution was undertaken as described in this subsection. The procedures to estimate mining dilution and ore loss for Castelo de Sonhos Project consisted in rearranging a block model suited for the selective dimension of mining equipment, calculating the dilution and ore loss factors based on the limits of the optimal pits and applying such factors to the resource block model. Each step of the estimate is described below.

16.3.1 Selective Mining Unit (SMU)

In order to estimate and account for the mining dilution and ore loss during the blasting and mining activities, an ancillary block model with dimensions suited to the mining method applied was developed.

Pre-Feasibility Study

The current resource block model in which Mineral Resources are estimated is regular with cell dimensions of 20 m x 20 m x 4 m (XYZ). For the mining dilution model, GE21 generated a block model adequate for bench mining with small excavators (4.0 m³ bucket) while considering proper grade control procedures during operation to establish the grade of each mined block and their destination.

The dimensions selected for the mining dilution model are 5 m x 5 m x 2 m (XYZ), even with a mining fleet selected for operation that can selectively mine blocks at smaller sizes than the SMUs dimensions.

To generate the mining dilution block model, GE21 performed a regularization on Esperança South block model by Local Uniform Conditioning (LUC) for the selected block sizes, with Isatis Neo software. The model properties are presented on Table 16-16.

Table 16-16 Mining dilution block model properties

	X	Y	Z
Number of nodes	704	904	302
Mesh size	5 m	5 m	2 m
Grid origin (corner)	723000.00 m	9088500.00 m	132.00 m

16.3.2 Dilution Estimate

With the Local Uniform Conditioning (LUC) performed for the Esperança South target, the Mineral Resource was constrained for the optimal pit generated, and the contact between blocks with gold content above cut-off grade (0.26 g/t) and those below was delineated. Figure 16-54 shows the contacts between such blocks in the mining dilution block model.

Pre-Feasibility Study

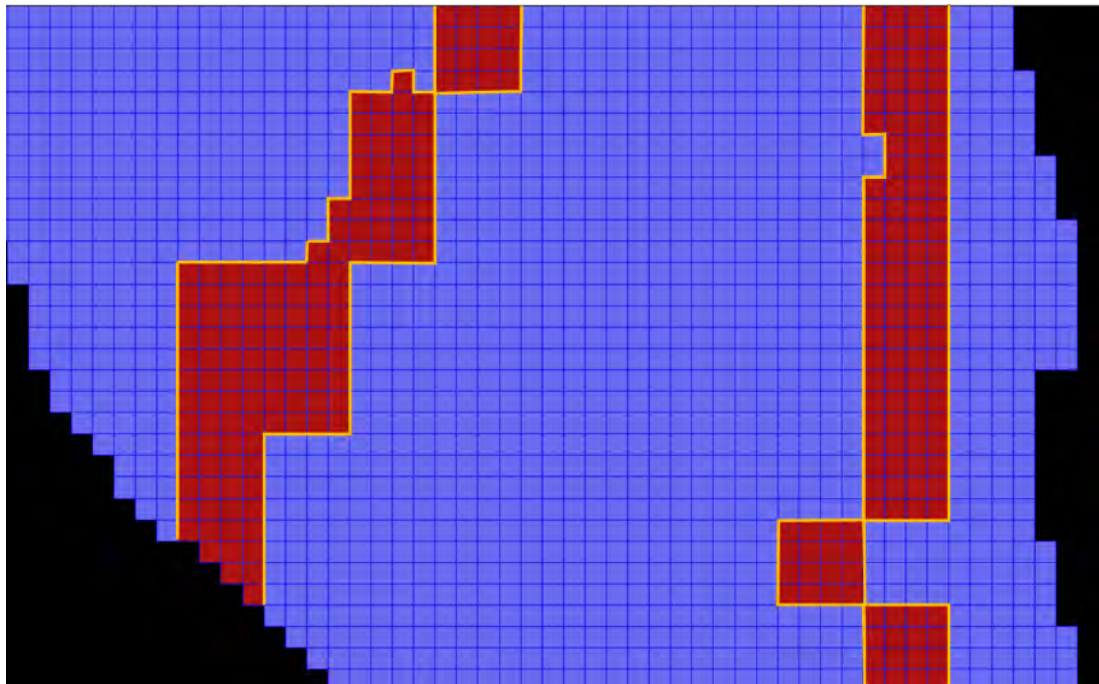

Figure 16-54 Contact between blocks for dilution estimate

Legend: Red blocks – Au ≥ 0.26g/t; Blue blocks – Au < 0.26g/t; Yellow line – contact for dilution purposes.

Whenever a contact between ore and waste was defined, a horizontal offset of 0.4 m, 20% of block height, was set as a possible dilution zone between adjacent blocks. To mitigate the ore loss and estimate the dilution, a grade control procedure was considered for mining activities, with a sample every 5 meters, aiding the mining decisions and therefore mitigating ore loss from operation inside the projected pit.

Using GEOVIA Surpac tools for calculating mining dilution, a secondary gold grade attribute was created to contain the diluted grades for each block. The diluted gold grade was reported in comparison to the original one from LUC procedures, with blocks that previously were below cut-off grade, at marginal grades above 0.24 g/t changing to values above cut-off grade. The blocks that previously had gold grade above 0.26 g/t and were diluted to lower values were also computed as ore, as they were planned to be mined and no ore loss was foreseen for the study.

The dilution of tonnage and grades for the blocks above cut-off grade of 0.26 g/t were calculated separately as some waste is mineralized, presenting lower gold grades. The formulas for dilution of mass and dilution of grades are presented below.

$$\text{Dilution of mass (\%)} = \frac{(\text{mass of waste delivered})}{(\text{mass of ore} + \text{mass of waste})} \times 100$$

$$\text{Dilution of grade (\%)} = \frac{(\text{resource grade} - \text{diluted grade})}{(\text{resource grade})} \times 100$$

Pre-Feasibility Study

16.3.3 Results

A mass dilution factor of 3.9% was achieved, together with a grade dilution factor of 4.5%. These modifying factors are included on the Mineral Reserves Statement.

16.4 Pit Design

The Mine Design or Pit Design, consists of projecting, based on an optimal pit, an operational pit that allows for the safe and efficient development of mining operations.

The methodology consists of establishing an outline of the toes and crests of the benches, safety berms, work sites and mining site access ramps while adhering to the geometric and geotechnical parameters that were defined. The assumptions that were adopted for the design of the final pits for each period of mining were:

- Minimize the loss of mineralized material
- Define the access routes to attain shorter average transport distances to the crushing circuit and waste disposal area

Table 16-17 presents the geometric parameters that were adopted to develop the mine design for each end of period. The data was obtained from similar projects on GE21 database and geotechnical considerations.

Table 16-17 Pit design parameters

Inter-ramp Slope Angle	55°
Face Angle	75°
Bench Height ROM	8m
Bench Height Waste	10m
Berm width	5m
Minimum bottom area	30m
Road Ramp width	12m

Table 16-18 presents the pit design results. Figure 16-55 presents the final pit design.

Pre-Feasibility Study

Table 16-18 Pit Design Results

TriStar PFS Castelo de Sonhos Block dimensions 20x20x4 (m) Mine Recovery 100%, Dilution 3.9% Grade Dilution 4.5%						
Target	ROM (Mt)	Waste (Mt)	Total Mov.	Au (g/t)	Ounces mined (Moz)	Strip Ratio
Esperança South	24.2	261.7	285.9	1.28	0.99	10.8
Esperança East	3.1	17.2	20.3	0.82	0.08	5.5
Esperança Center	11.4	68.5	79.9	0.78	0.29	6.0
Total	38.7	347.4	386.1	1.09	1.36	9.0

Pre-Feasibility Study

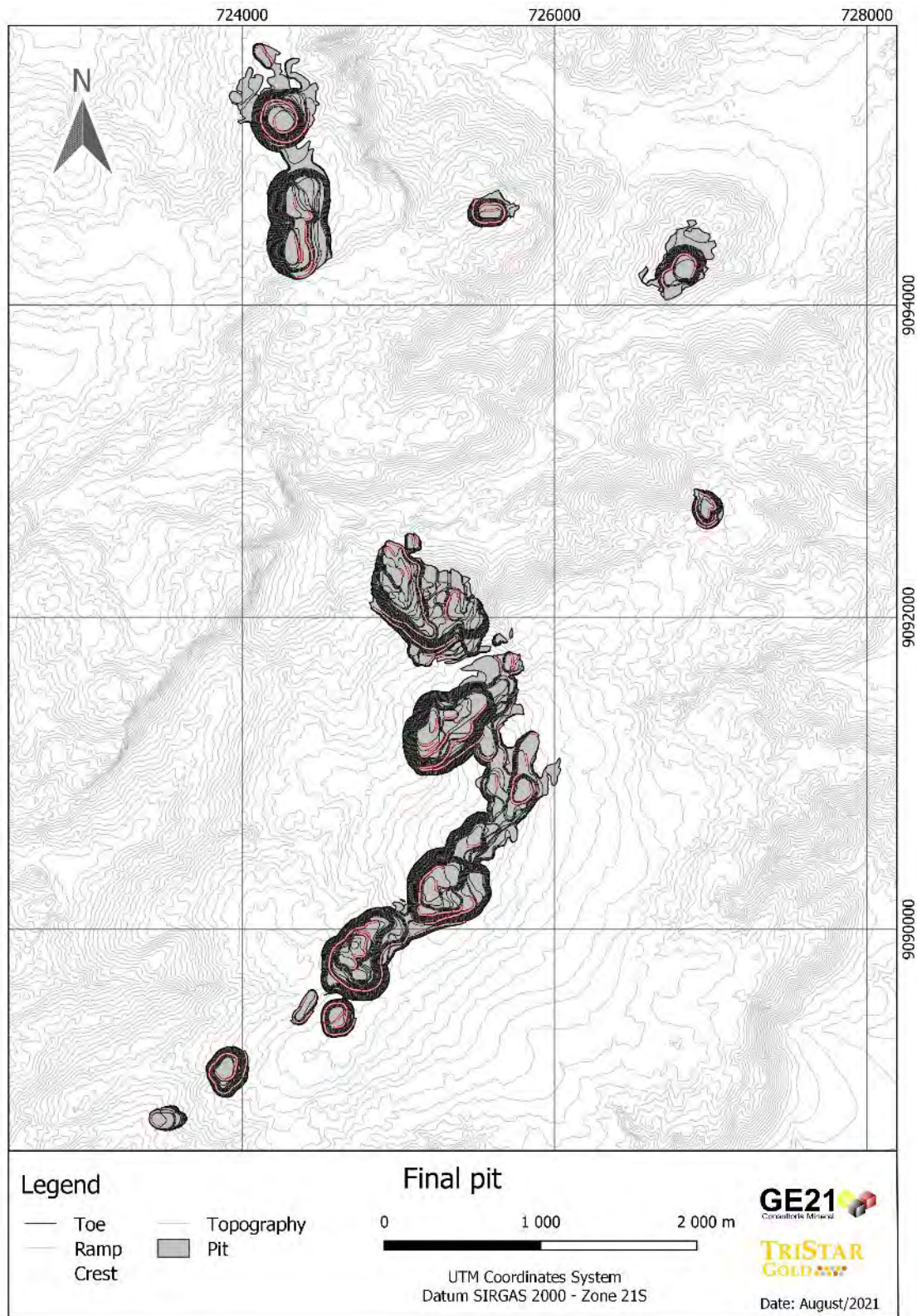

Figure 16-55 Final Pit – CDS Project

Pre-Feasibility Study

16.5 Mine Schedule

The mine production scheduling was generated in Geovia Minesched™ 9.1.0, where the following assumptions used were:

- Production rate: 3.65 Mtpa
- ~150kt ounces mined on each of first five years
- Modifying factors: Mass dilution 3.9%, Grade dilution 4.5%

This study consisted of establishing annual production schedules for the Run-of-mine (ROM) and waste mining sequence, as well as the evolution of the geometries throughout the life of the mine (LOM).

For the development of the production program, the areas to be mined annually were established, thus generating operational plans for years 1 to 11. Open pit operations are anticipated to run for 11 years with Phase 1 (Esperança South) on the first 6 years of operation, and Phase 2 (Esperança East and Esperança Center) on the following 2 and 3 years of operation, respectively. No pre-stripping is foreseen.

The results of mining schedule are summarized in Table 16-19

Table 16-19 Mining Schedule Production

Mine Design Scheduling							
Mass diluted by 3.9%, Grade diluted by 4.5%							
Year	Target	ROM (Mt)	Waste (Mt)	Total Mov.	Au (g/t)	Ounces mined (koz)	Strip Ratio
1	ES	3.41	39.23	42.64	1.42	155.4	11.5
2	ES	3.60	42.46	46.06	1.30	150.4	11.8
3	ES	3.67	43.28	46.94	1.27	150.0	11.8
4	ES	3.29	44.64	47.93	1.43	151.7	13.6
5	ES	3.62	44.45	48.07	1.29	150.3	12.3
6	ES	3.65	28.92	32.56	1.16	135.6	7.9
7	ES & EE	3.55	22.26	25.81	1.02	116.0	6.3
8	EE & EC	3.65	19.78	23.43	0.69	81.1	5.4
9	EC	3.45	21.84	25.29	0.79	87.7	6.3
10	EC	3.63	21.93	25.56	0.83	97.1	6.1
11	EC	3.21	18.61	21.83	0.82	84.5	5.8
Total	-	38.72	347.40	386.12	1.09	1 359.7	9.0

16.5.1 Mine Schedule Design

Following Figure 16-56 to Figure 16-66 present the mine design of the end of periods for years 1 to 11. On the Appendix A is presented the detailed maps of the mining sequence by target.

Pre-Feasibility Study

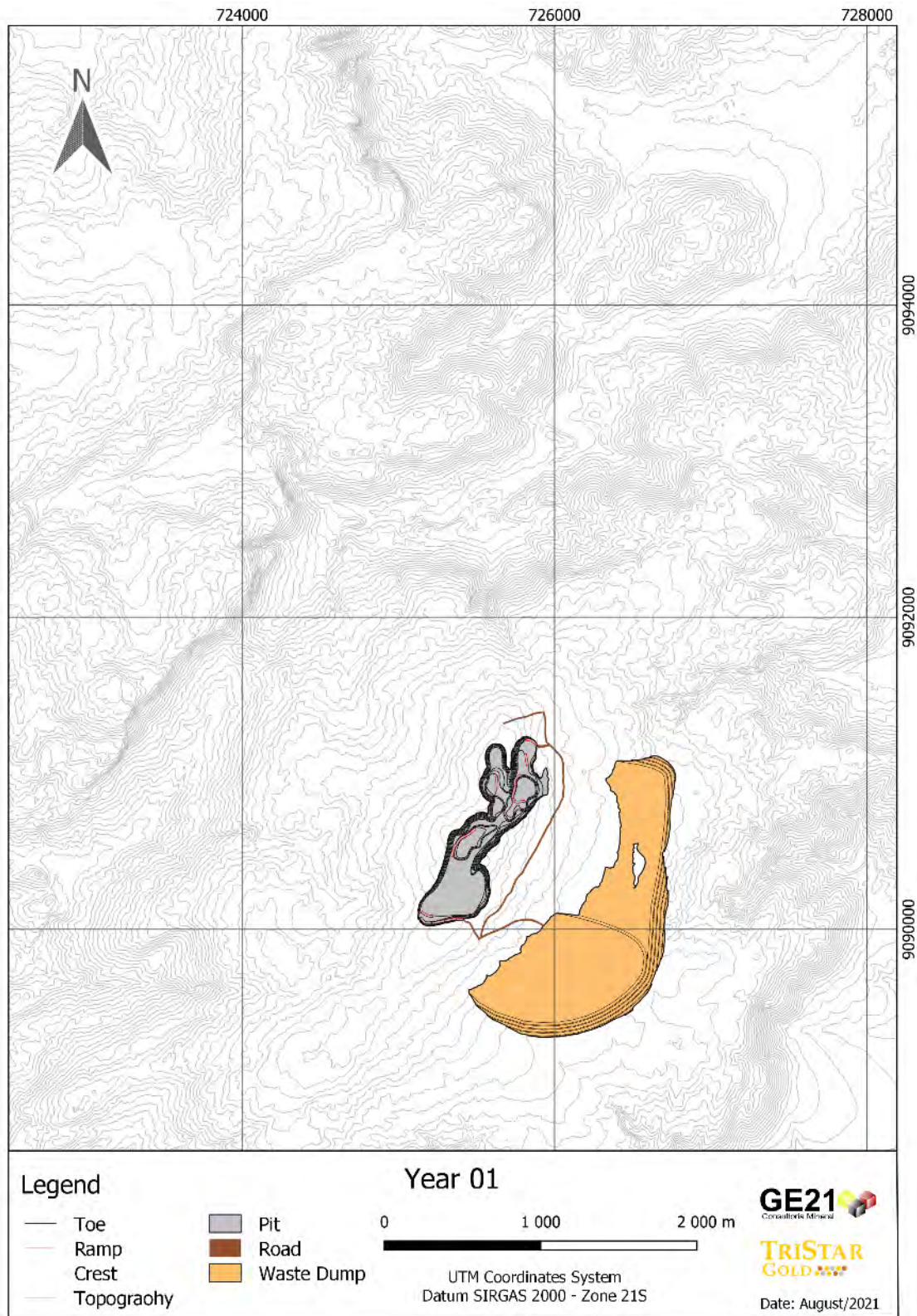

Figure 16-56 Year 01

Pre-Feasibility Study

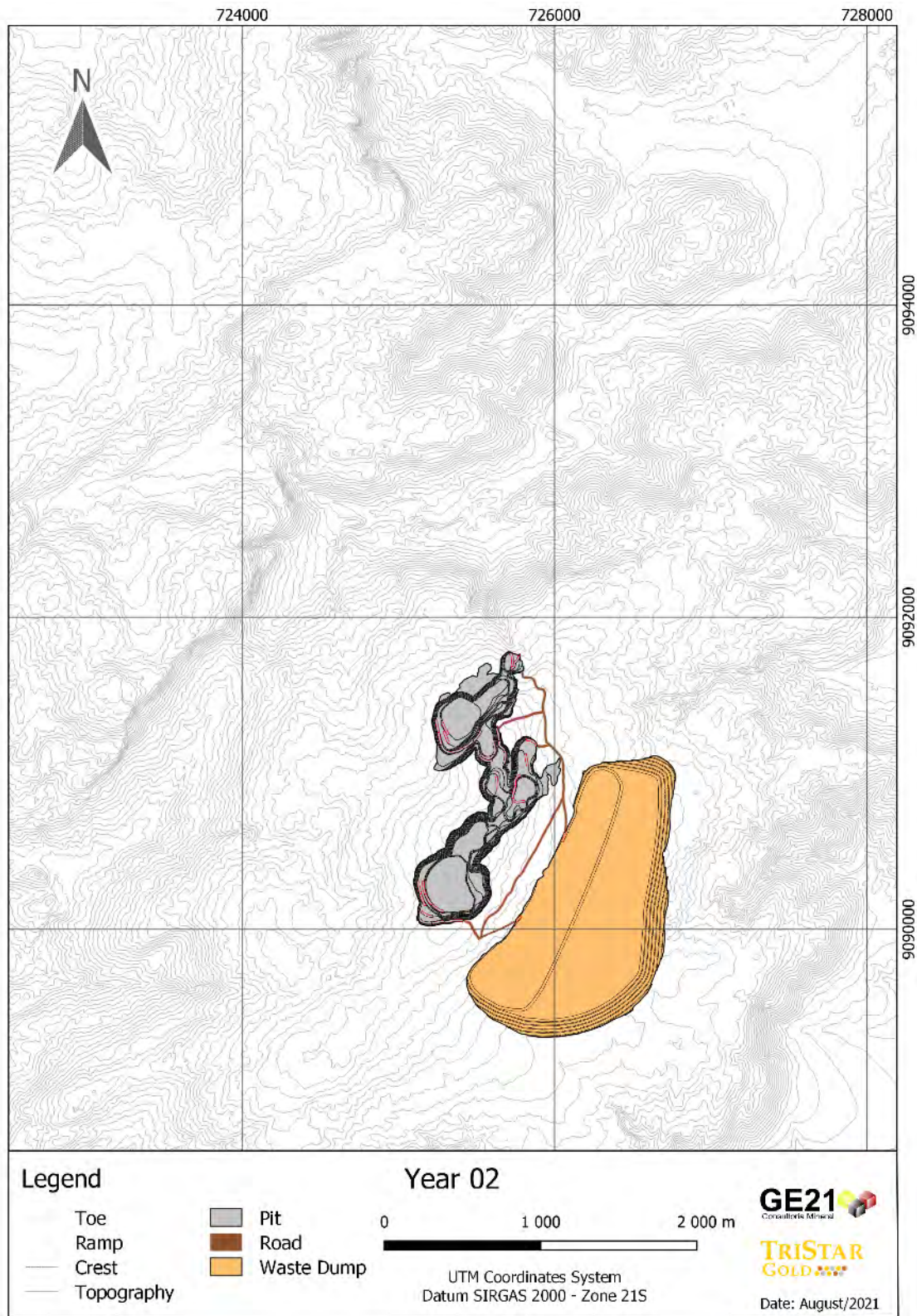

Figure 16-57 Year 02

Pre-Feasibility Study

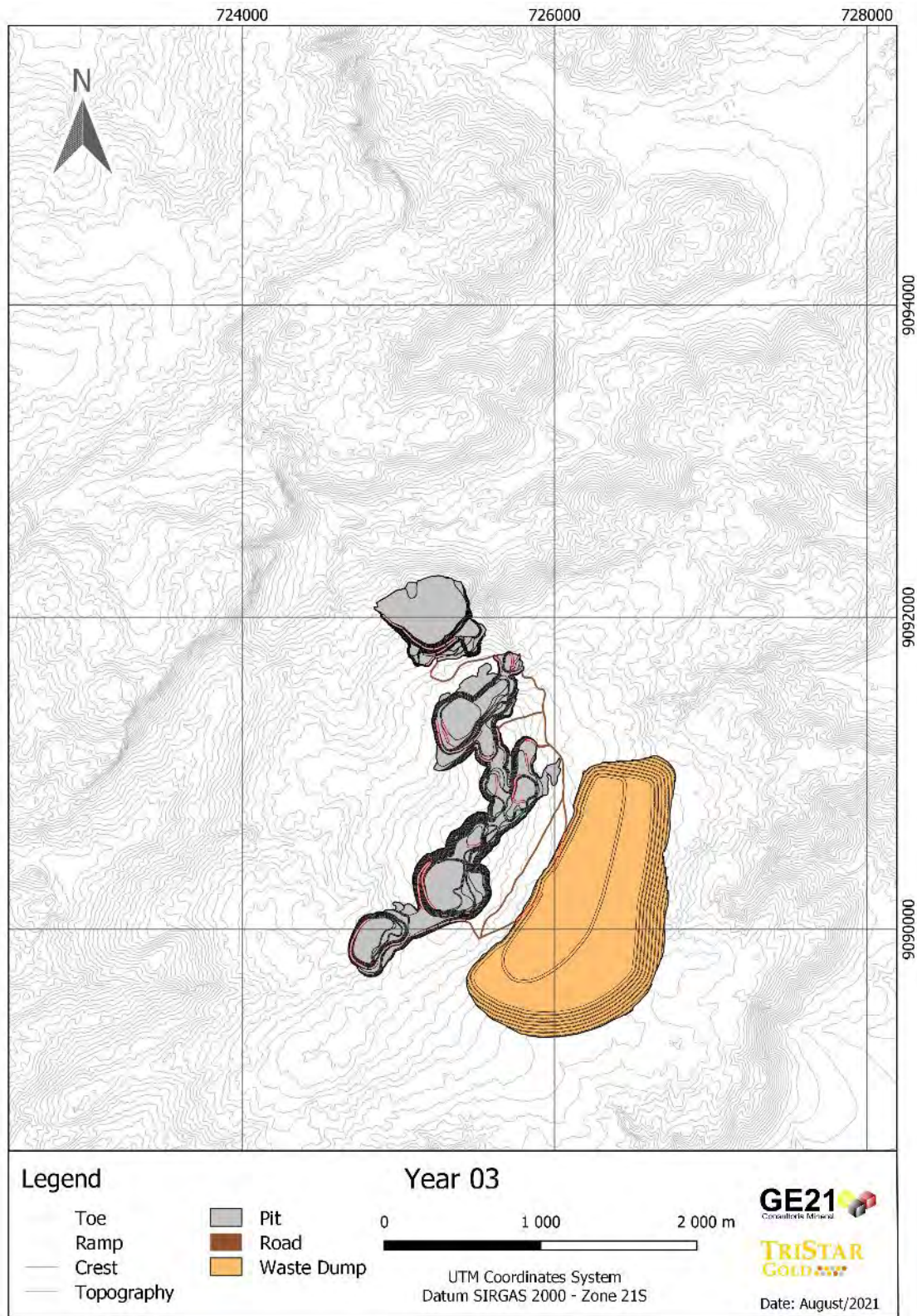

Figure 16-58 Year 03

Pre-Feasibility Study

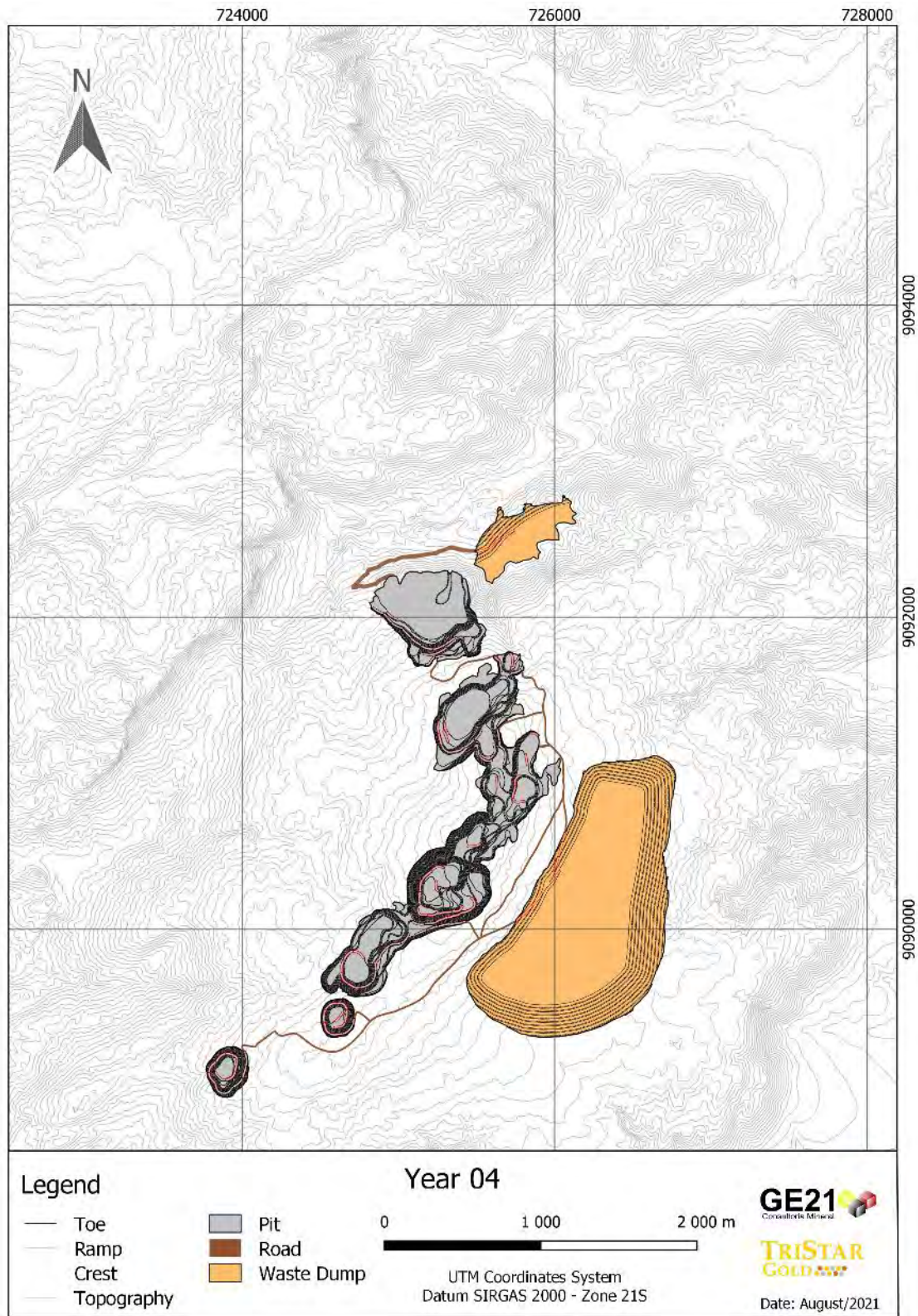

Figure 16-59 Year 04

Pre-Feasibility Study

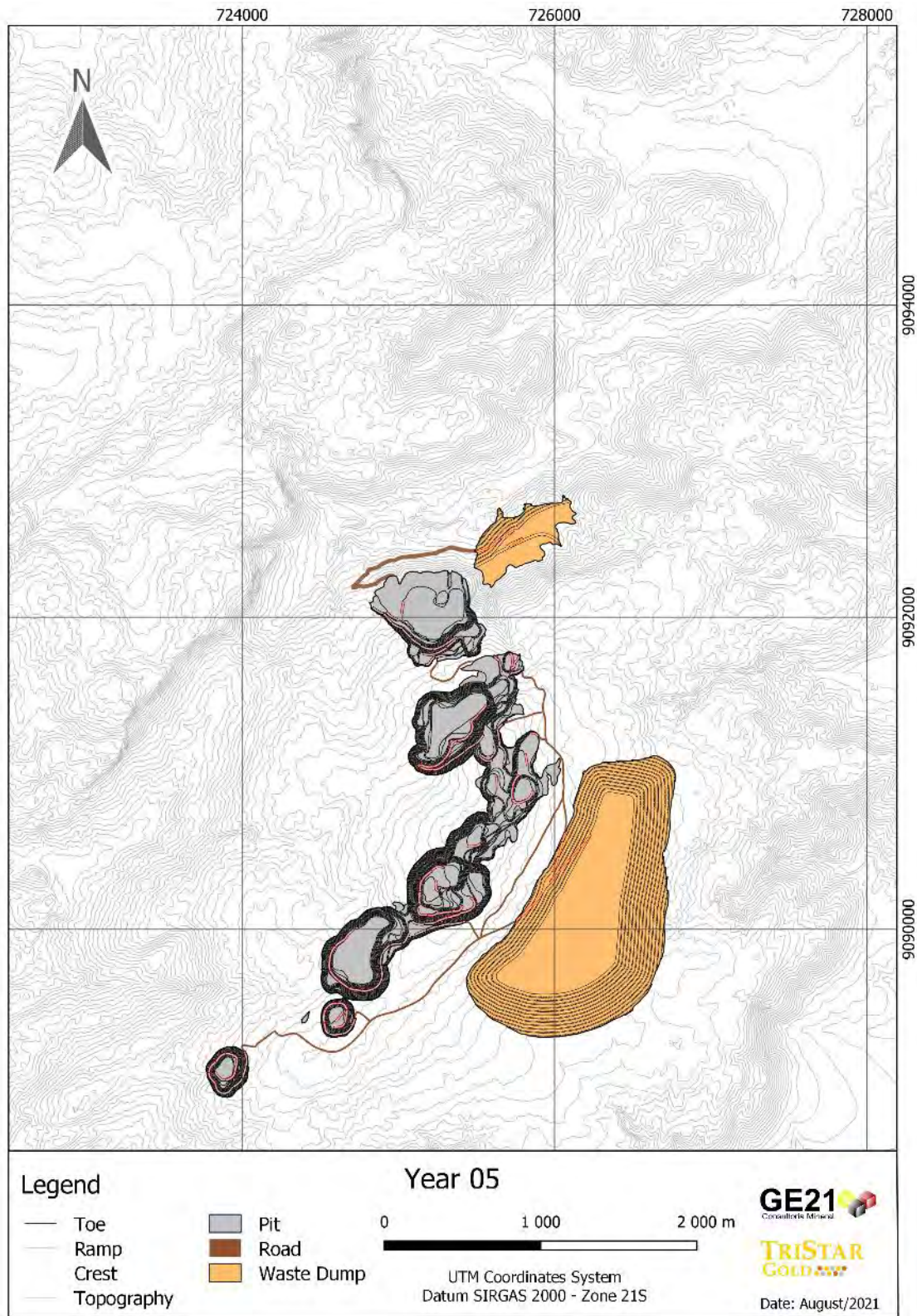

Figure 16-60 Year 05

Pre-Feasibility Study

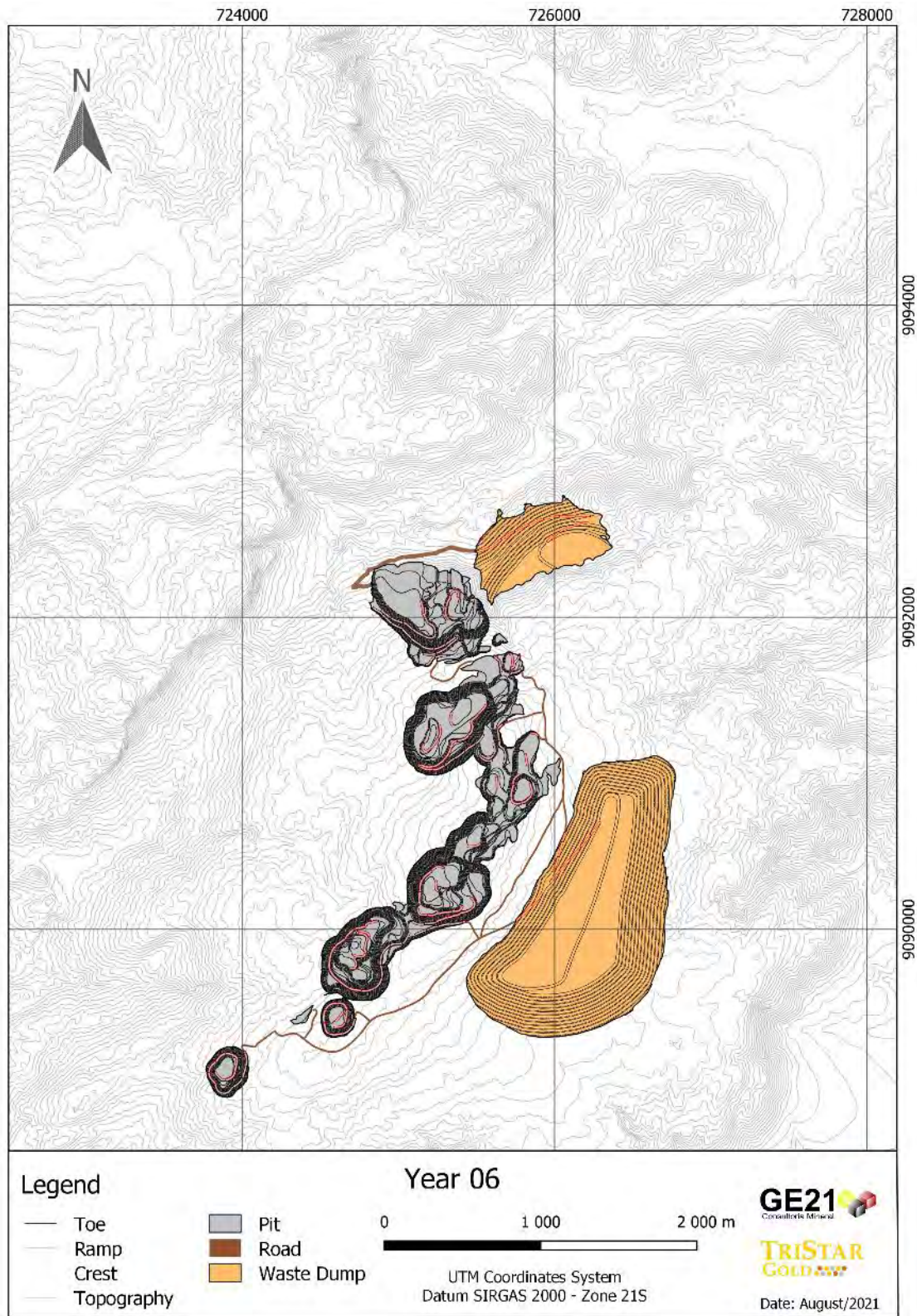

Figure 16-61 Year 06

Pre-Feasibility Study

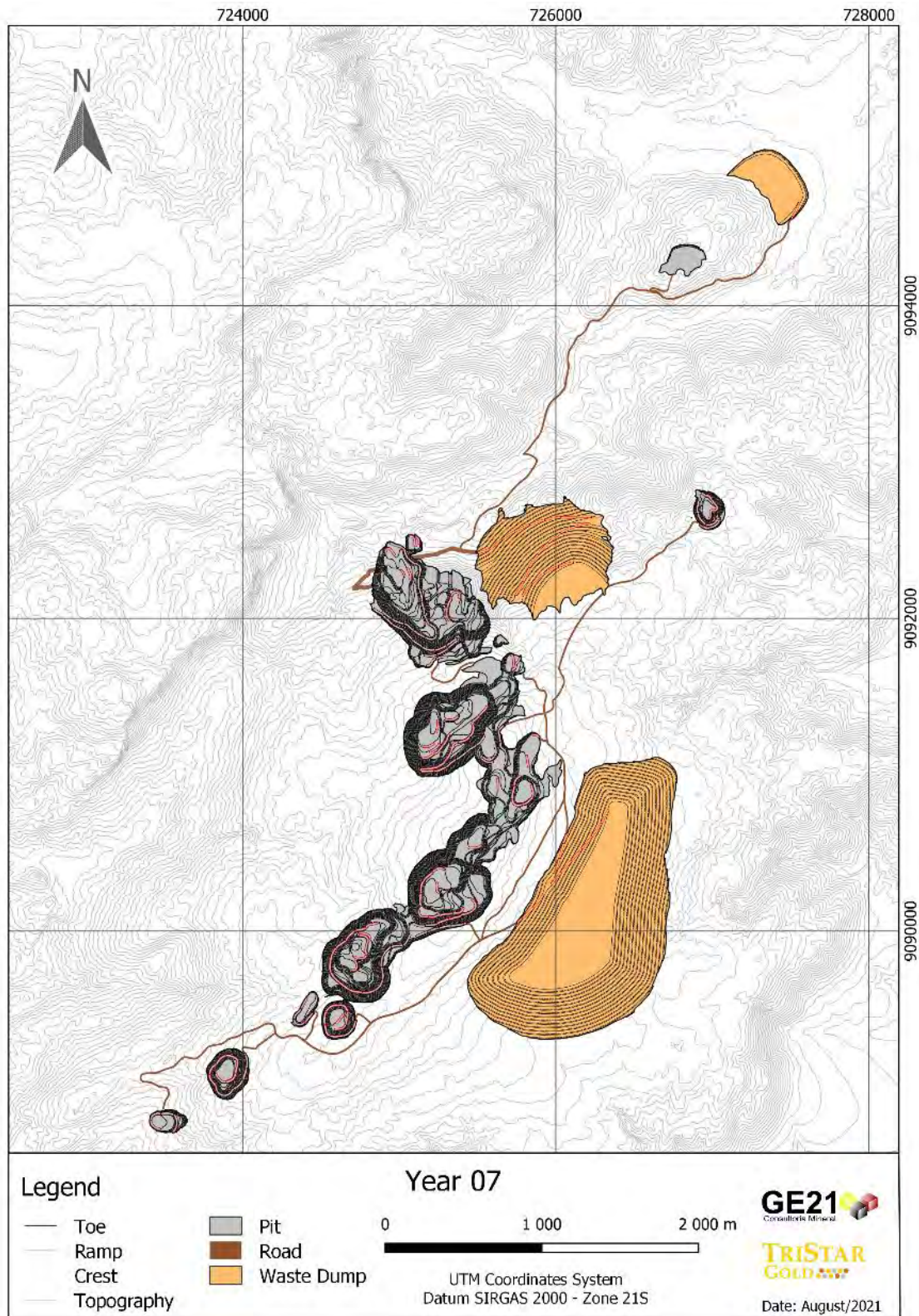

Figure 16-62 Year 07

Pre-Feasibility Study

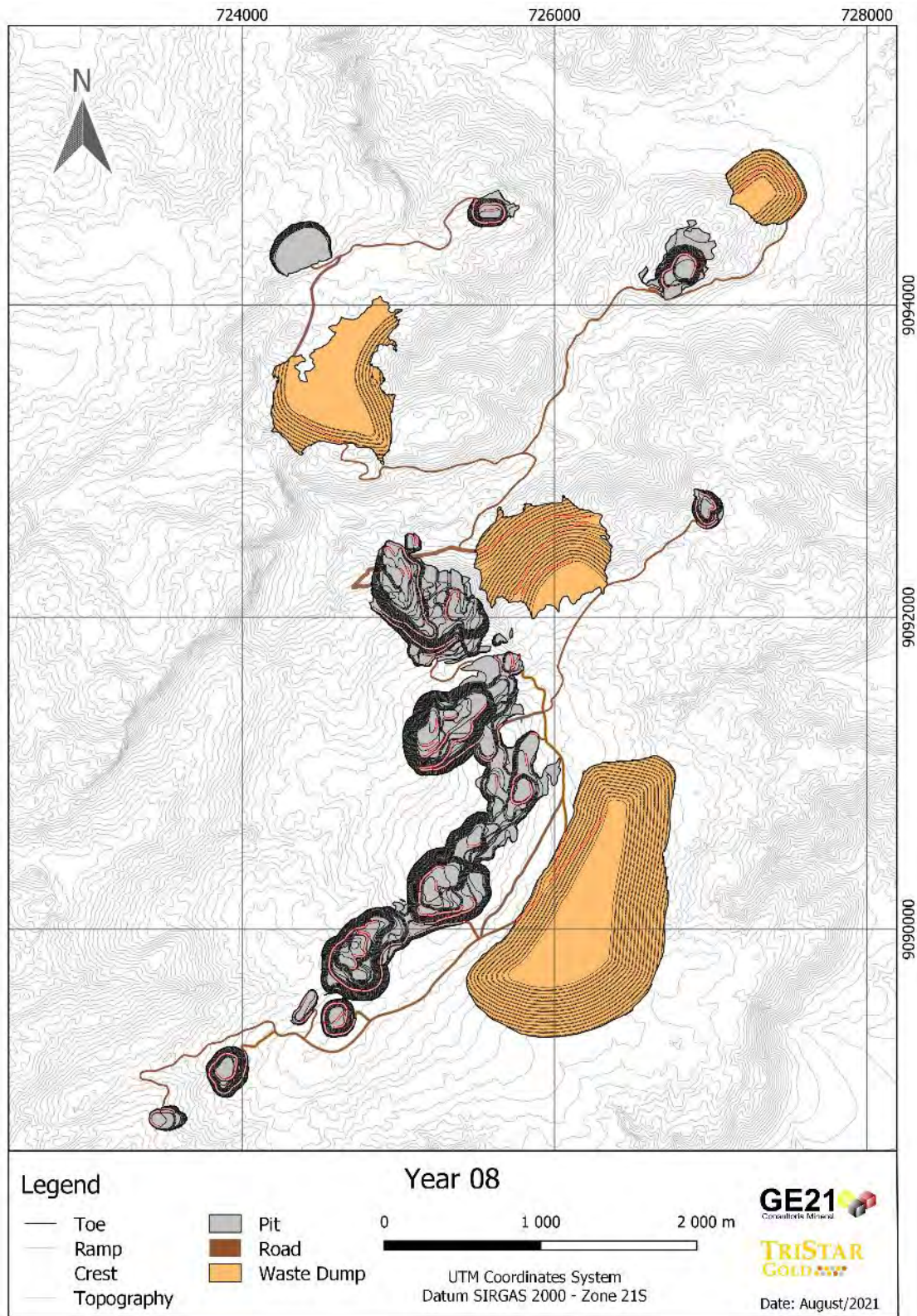

Figure 16-63 Year 08

Pre-Feasibility Study

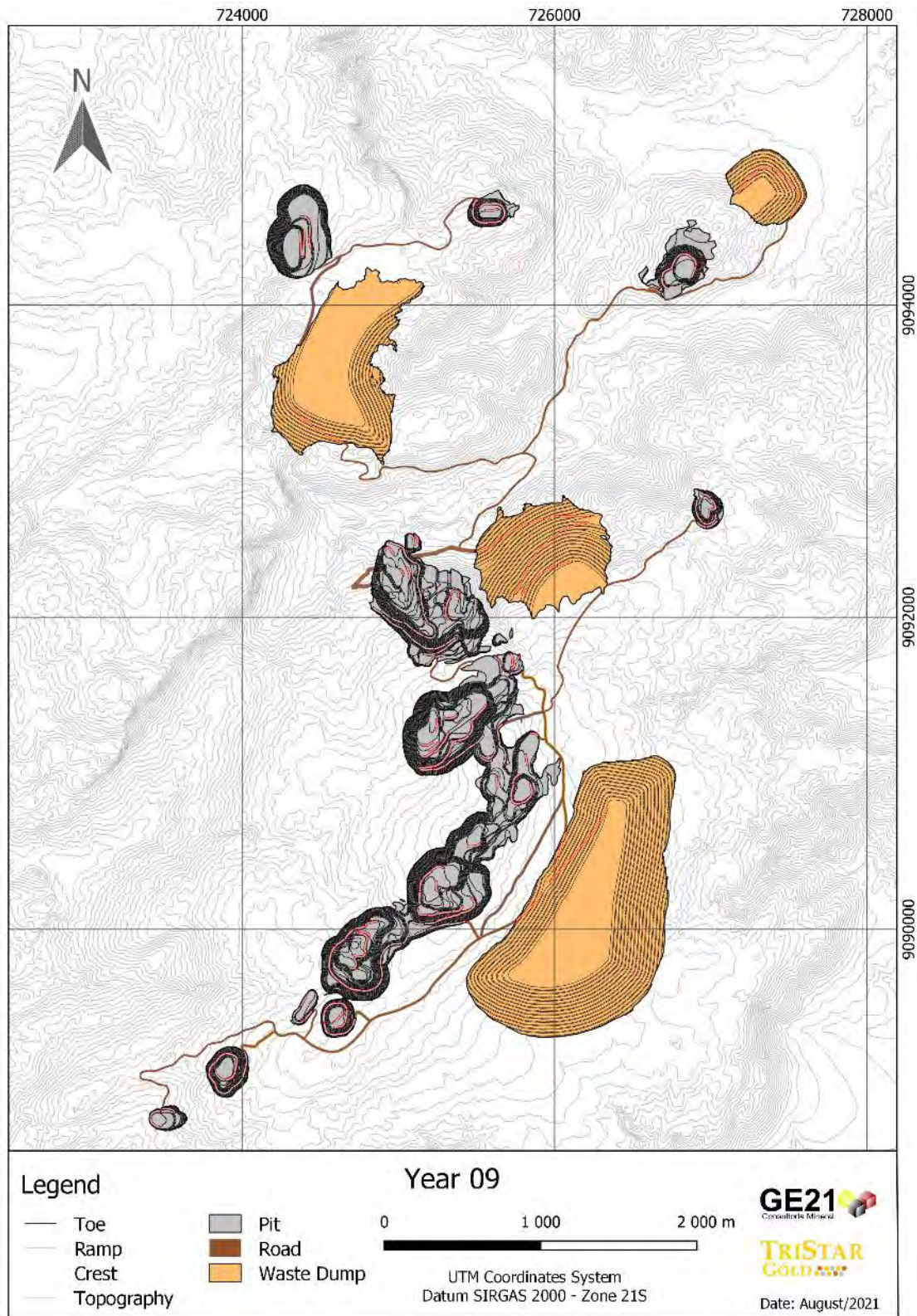

Figure 16-64 Year 09

Pre-Feasibility Study

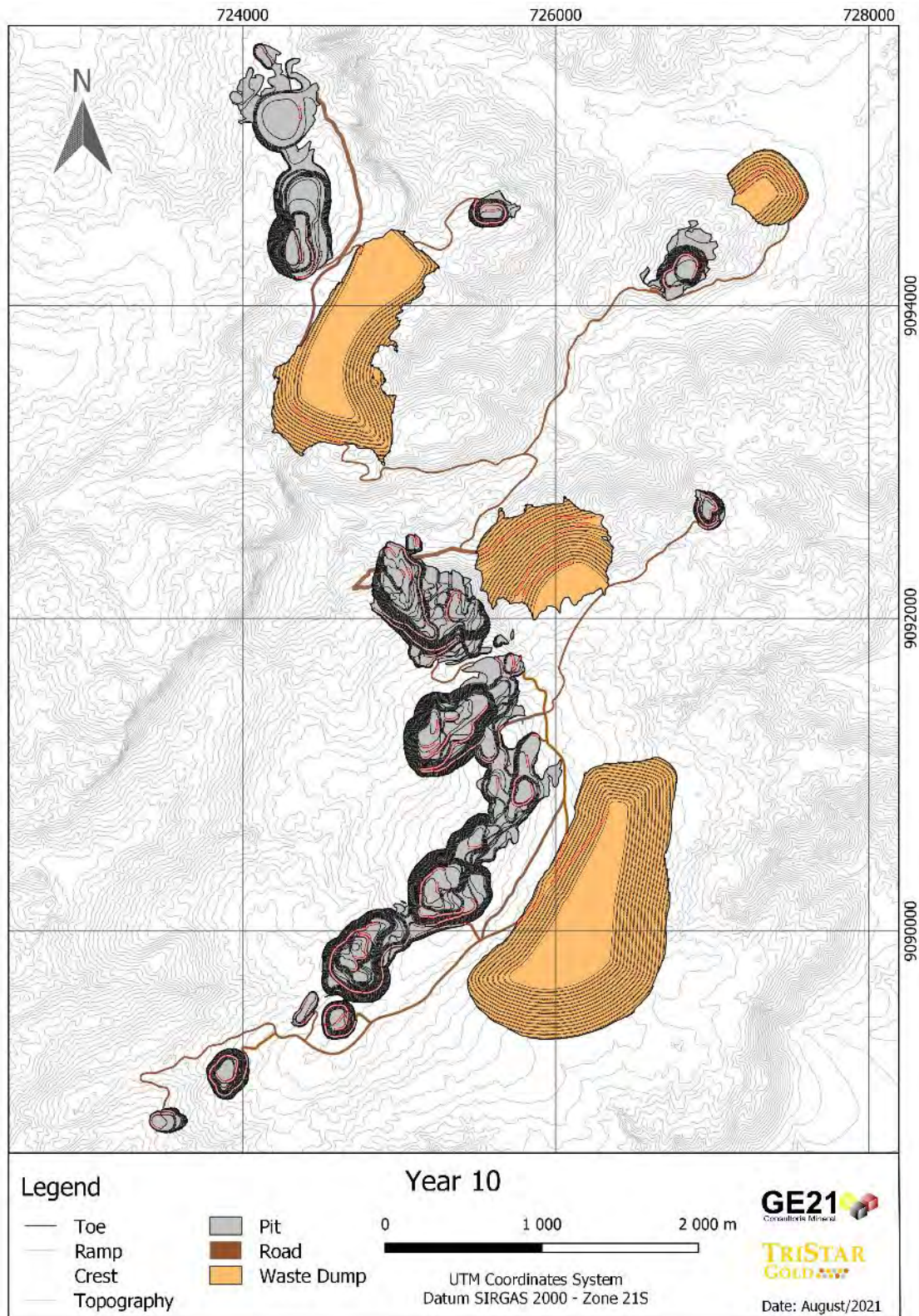

Figure 16-65 Year 10

Pre-Feasibility Study

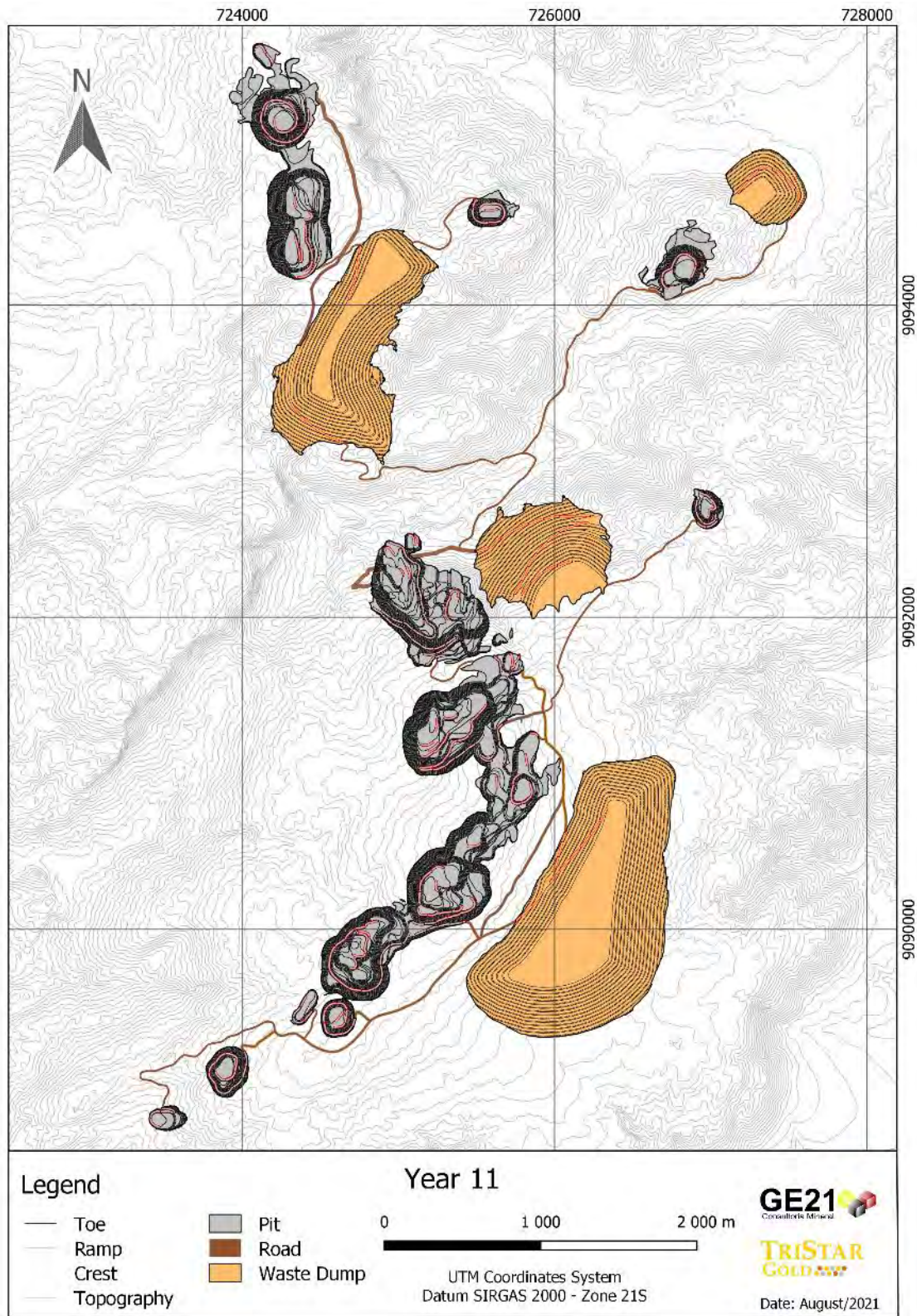

Figure 16-66 Final pit

Pre-Feasibility Study

16.6 Waste Disposal

The ROM with contents below the minimum acceptable by the Processing Plant, even though mineralized, will be excavated, loaded, transported, and disposed in the waste dumps, following the respective project of each dump. All fleets for mining activities have been selected and sized for both mining and waste removal.

Waste rock will be loaded, transported, and disposed in the corresponding waste dump. All the layout must to be in conformity with the waste dump project and in accordance with the projected disposal sequencing to the waste rock.

For disposal and conformation of the material in the waste stockpiles, bulldozers model Cat D8 and Cat D6 will be used. The compaction of waste will be carried out through the transit of the trucks themselves that traffic through it. In the final benches of the waste dumps, finishes necessary to the implementation of the system of superficial drainage and revegetation will be carried out.

Table 16-20 presents the geometric parameters and Table 16-21 volumes of each waste dumps. The conceptual layout for the waste dumps is presented in Section 18.

Table 16-20 Waste dumps design parameters

Slope Angle	29°
Bench Height	10m
Berm width	5m
Road Ramp width	12m

Table 16-21 Waste dumps volume and areas

Waste Dump	Volume (Mm ³)	Area (ha)
ESN	23.6	46.9
ESS	96.7	147.2
EC	35.9	80.6
EE	5.57	17.5

16.7 Production Plan

Based on the production plan for ore and waste, as well as the average haulage distances on yearly basis, a fully owned mining fleet was estimated for Castelo de Sonhos Project.

Mining operations basically comprises on: Drilling and blasting with explosives, haulage, ROM and waste haulage, ROM discharge at crushing circuit and waste disposal at proper waste dumps. Furthermore, mine infrastructure operations and ancillary equipment were estimated.

Pre-Feasibility Study

The ROM will be mined, hauled and transported by trucks and discharged to the hopper of crushing circuit. A ROM pad will be set nearby, guaranteeing a minimal ROM stockpile of approximately 20,000 tonnes, two-day period of the processing plant. This stockpile will be reclaimed by wheel loaders, aiming at the regularization of the plant feed in case of unexpected stop of production.

16.7.1 Mining Fleet

For the characteristics of the mine, the mass of ROM to be mined and the volume of waste to be removed and the economy of operations, it was decided to use trucks with 42t of load capacity and 70t hydraulic excavators. Other equipment was selected and sized according to the size of the trucks and excavators.

In addition to the fleet of excavators and trucks mentioned above, the following were also selected and dimensioned: Shovels, Drills, Bulldozer, Motor Graders, Water Trucks, and other equipment to support the operation.

All fleets for mining activities have been selected and sized for both ore mining and waste removal. All the selected equipment is manufactured in Brazil and is well supported by networks of distributors.

16.7.2 Access Routes

All the accesses required for the operations are designed to reduce transport distances between origins and destinations, whilst also strictly following the technical and safety parameters and standards of equipment for transport. The ramps have 10% maximum grade, curves have a minimum of 30-meter radius and widths of the bearing track, which will be 2 times the width of the largest vehicle used for single-direction lanes and 3 times the width of the largest vehicle used. All accesses will have lateral protection curbs with minimum height equal to half the tire diameter of the largest equipment that transits through the access roads.

Aiming at the safety of operations, workers' health and mitigation of the environmental impacts of the operation, water trucks will be kept in operation in a regime of 24 hours/day of operation, guaranteeing an efficient wetting of all accesses that are being used.

Bulldozers, motor graders, a small hydraulic excavator, water trucks and a compactor roller will be used for the construction and maintenance of the roads.

The road signalling system will be implemented according to the Brazilian traffic regulations and specific standards for mining. Special care will be taken regarding the safety and signalling, throughout the route. All accesses will meet the Brazilian regulatory standards regarding transit and mining specificities (Regulation Mining Standards - NRM).

16.7.3 Drilling and Blasting

The assumptions considered for the drilling and blasting plan were based on similar projects to Castelo de Sonhos, with parameters from GE21 database. With the beginning of operations, rock

Pre-Feasibility Study

hardness tests, drilling advance rates and fragmentation tests shall be undertaken and the drilling and blasting plans adjusted accordingly. For this study, it was estimated that 90% of both ore and waste are hard rocks and need blasting with explosives.

In order to achieve selectivity in mining, 5 meters high ore benches and 10 meters high waste benches were considered.

To perform the secondary blasting, when necessary, they will also be carried out with explosives or with the use of hydraulic hammer coupled with a hydraulic excavator or with the use of bulldozer.

In relation to the storage of explosives in the mine, a specific location for the installation of an Explosive Storage is designated and presented in the general layout map. The second option is the implementation of an Explosives Mixing Plant to be located at the TriStar Mine. The main objective of this plant is to avoid the storage of ready-to-use explosives and consequently a significant reduction in surveillance costs. In this plant, only the explosives mixed in the same day will be produced. Explosives Mixing Plant located in mines have been a trend in Brazil.

16.8 Mine Fleet Sizing

The mining equipment was selected according to the mass of ROM to be extracted, the volume of waste to be removed and the characteristics of the mine. For purposes of dimensioning the drilling, blasting, haulage and waste disposal, an average moisture of 6% and a swell factor of 20% with compacting were applied.

For the demands of production and ROM, removal of waste and average distances to be travelled by trucks. A more detailed assessment is recommended when purchasing the fleet, to verify the economic feasibility of outsourcing part of the waste to be removed, avoiding significant variations in the number of equipment to be acquired each year.

For the mining fleet, it is foreseen, during the peak of production on Phase 1 – first six years of operation, 13 CAT 374 hydraulic excavators equipped with a 2.8 – 4.5 m³ bucket and a peak of 52 Scania G500 8x4 trucks with 42t capacity. For drilling, a peak of 12 Sandvik Leopard Di650i drill rigs is foreseen. A fleet of ancillary equipment is also available for mine maintenance and eventual plant services. Table 16-22 presents the equipment quantities and Table 16-23 presents equipment specification.

Pre-Feasibility Study

Table 16-22 Equipment Quantitative

Mining Fleet	Years										
	1	2	3	4	5	6	7	8	9	10	11
Hydraulic Excavator -70 t (2.8 – 4.5 m ³)	11	12	13	13	12	8	7	7	7	7	6
Road Truck 42t - 8x4	34	43	52	48	46	33	30	32	35	36	32
Drilling Machine	11	11	12	12	12	8	7	6	7	7	6
Wheel Loader (3.2 – 7.4 m ³)	1	1	1	1	1	1	1	1	1	1	1
Bulldozer CAT D8	4	4	4	4	4	3	2	2	2	2	2
Bulldozer CAT D6	4	4	5	5	4	3	3	3	3	3	2
Wheel Dozer CAT 834H	2	2	3	3	2	2	1	1	1	1	1
Grader - Caterpillar	3	3	3	3	3	2	2	2	2	2	2
Operation Support Truck - Scania	3	3	3	3	3	2	2	2	2	2	2
Water Truck – 20,000 L	4	4	4	4	4	3	2	2	2	2	2
Backhoe Excavator	2	2	3	3	2	2	1	1	1	1	1
Hydraulic Excavator - 35 t with Hammer	2	2	3	3	2	2	1	1	1	1	1
Forklift	3	3	3	3	3	2	2	2	2	2	2
Blasting & Support Truck - Scania	3	3	3	3	3	2	2	2	2	2	2
Fuel & Lube Truck - 8.000 L	3	3	3	3	3	2	2	2	2	2	2
Maintenance Support Truck - Munck	3	3	3	3	3	2	2	2	2	2	2
Crane - 30 t of capacity	1	1	1	1	1	1	1	1	1	1	1
Portable lighting Tower	8	8	9	9	8	6	5	5	5	5	4
Light Vehicle	6	6	7	7	6	4	4	4	4	4	3
Total	107	118	134	130	122	88	76	77	81	82	74

Pre-Feasibility Study

Table 16-23 Equipment Specification

Equipment	Reference	Model	Life
	Manufacturer		(Hours)
Hydraulic Excavator -70 t (2.8 – 4.5 m ³)	Caterpillar	CAT 374	30,000
Road Truck 42 t - 8x4	Scania	Heavy Tipper G500	15,000
Drilling Machine	Leopard Di650i	Leopard Di650i	25,000
Wheel Loader (3.2 – 7.4 m ³)	Caterpillar	CAT 966	30,000
Bulldozer CAT D8	Caterpillar	D8T	35,000
Bulldozer CAT D6	Caterpillar	D6T	35,000
Wheel Dozer CAT 834H	Caterpillar	CAT 834	30,000
Grader - Caterpillar	Caterpillar	Cat 140 M	35,000
Operation Support Truck - Scania	P360	P360	15,000
Water Truck – 20,000 L	VOLVO	FMX	18,000
Backhoe Excavator	Caterpillar	CAT432F	15,000
Hydraulic Excavator - 35 t with Hammer	Komatsu	PC 350	30,000
Forklift	Mitsubishi	FD35N3	36,000
Blasting & Support Truck - Scania	P360	P360	15,000
Fuel & Lube Truck – 8,000 L	VOLVO	FMX	18,000
Maintenance Support Truck - Munck	Mercedes	Axor 3131	20,000
Crane - 30 t of capacity	Grove	GMK 3055-9622	36,000
Portable Lightning Tower	Patria	LS4	7,000
Light Vehicle	Toyota	4WD Prado	6,000

16.8.1 Ore and Waste Rock Excavation and Load

Excavation and the loading of ore and waste rock will be carried out by hydraulic excavators in backhoe configuration. Due to the blending of ores, at least two mining fronts will be operated simultaneously, and for mine development issues, aiming at the release of ore in the planned qualities, also for the removal of waste rock will be kept simultaneously at least two work fronts.

The excavators with the backhoe configuration allow the excavation by positioning the machine on the upper operating bench, keeping the transport equipment in the lower operating bench. This model allows a substantial increase in the productivity of the set, since the truck will be positioned approximately 30° from the longitudinal axis of the excavator, allowing shorter turning time of the machine when in excavation and loading. With the upper positioning of the loading machine, the field of view of the operator increases considerably, consequently increasing the safety of the operation, the productivity, the positioning of the load on the truck and principally enables a better selectivity in ore mining. Table 16-24 shows the amount of excavation and loading equipment.

Pre-Feasibility Study

Table 16-24 Excavation and Load Equipment

	Years				
Excavator	1	2	3	4	5
ROM x 1,000 t	3,406	3,596	3,665	3,291	3,622
Waste x 1,000 t	39,230	42,463	43,277	44,641	44,453
Number of Units (Ore)	0.88	0.93	0.95	0.85	0.94
Number of Units (Waste)	10.15	10.99	11.2	11.55	11.5
Hours per Year Fleet - Total	55,240	59,674	60,818	62,100	62,286
Hours per Year Fleet - Ore	4,413	4,659	4,748	4,264	4,693
Hours per Year Fleet - Waste	50,827	55,016	56,070	57,837	57,593
Number of Units - Rounded	11	12	13	13	12

	Years					
Excavator	6	7	8	9	10	11
ROM x 1,000 t	3,649	3,548	3,648	3,454	3,627	3,213
Waste x 1,000 t	28,916	22,262	19,781	21,835	21,934	18,613
Number of Units (Ore)	0.94	0.92	0.94	0.89	0.94	0.83
Number of Units (Waste)	7.48	5.76	5.12	5.65	5.68	4.82
Hours per Year Fleet - Total	42,191	33,440	30,354	32,765	33,117	28,278
Hours per Year Fleet - Ore	4,727	4,597	4,726	4,475	4,700	4,162
Hours per Year Fleet - Waste	37,463	28,843	25,628	28,290	28,418	24,116
Number of Units - Rounded	8	7	7	7	7	6

16.8.2 Wheel Loader for reclaiming Ore from ROM Stockyard

For sizing the wheel loaders, it was considered that 20% of the ROM mass will be discharged in the ROM stockyard, next to the primary crusher. The reclaiming will be carried out by the wheel loader, which feeds the hopper of the primary crusher. Table 16-25 shows the amount of wheel loader equipment.

Pre-Feasibility Study

Table 16-25 Wheel Loader

	Years				
Wheel Loader	1	2	3	4	5
ROM to be reclaimed x 1,000 t	681	719	733	658	724
Number of Units - Ore at the ROM stockyard	0.41	0.43	0.44	0.39	0.43
Number of Units - Rounded	1	1	1	1	1
Hours per Year Fleet - Ore	1,394	1,471	1,500	1,346	1,482

	Years					
Wheel Loader	6	7	8	9	10	11
ROM to be reclaimed x 1,000 t	730	710	730	691	725	643
Number of Units - Ore at the ROM stockyard	0.44	0.42	0.44	0.41	0.43	0.38
Number of Units - Rounded	1	1	1	1	1	1
Hours per Year Fleet - Ore	1,493	1,452	1,492	1,413	1,484	1,314

16.8.3 Transport

At sizing the transport fleet, the access parameters (uphill, downhills, width, ramp inclination), transport distances and work sites were evaluated. To meet the transportation equipment planned productivity, the access to the work fronts shall be in perfect conditions of trafficability and visibility. The access points will be built and corrected according to production planning in order to minimize transport distances and allow adequate productivity for the truck fleet.

16.8.4 Truck Fleet

Truck with payload capacity of 42 metric tons was adopted for this project for cost effectiveness. This truck option is widely used in medium-sized mining operations in Brazil with demonstrated economic advantages.

The average transport distances were calculated from the mining sequencing between the points of origin and destination. The average haul cycle considered a 7.5-minute fixed time for load, turn, spot, dump and interference, with average truck speed of 20km/h loaded and 35km/h empty. Table 16-26 demonstrates the truck productivity parameters and

Table 16-27 shows truck units required.

Pre-Feasibility Study

Table 16-26 Truck Productivity

Calendar hours	8,760
Availability	83%
Utilization	85%
Worked hours	6 180
Efficiency factor	85%
Effective productive hours per year	5,253
Average Truck Payload (t)	

Table 16-27 Year-by-year summary of usage of 42t trucks

Truck 42 mt	1	2	3	4	5
Total ROM x 1.000 t - Wet Basis	3,406	3,596	3,665	3,291	3,622
Total Waste x1.000 t - Wet Basis	39,230	42,463	43,277	44,641	44,453
Truck Unit Production - Ore (tpy*1.000)	857	814	624	576	718
Truck Unit Production - Waste (tpy*1.000)	1,317	1,116	942	1,071	1,096
Number of Units					
Total Trucks - Ore	4	4.4	5.9	5.7	5
Total Trucks - Waste	29.8	38.1	45.9	41.7	40.6
Total	33.8	42.5	51.8	47.4	45.6
Hours per Year - Fleet - Total	177,424	223,092	272,174	248,881	239,577
Hours per Year - Fleet - Ore	20,891	23,201	30,850	30,013	26,503
Hours per Year - Fleet - Waste	156,533	199,890	241,323	218,868	213,074
Number of Units - Rounded	34	43	52	48	46

Truck 42 mt	6	7	8	9	10	11
Total ROM x 1.000 t - Wet Basis	3,649	3,548	3,648	3,454	3,627	3,213
Total Waste x1.000 t - Wet Basis	28,916	22,262	19,781	21,835	21,934	18,613
Truck Unit Production - Ore (tpy*1.000)	573	531	310	288	287	260
Truck Unit Production - Waste (tpy*1.000)	1,087	973	973	950	950	950
Number of Units						
Total Trucks - Ore	6.4	6.7	11.8	12	12.6	12.3
Total Trucks - Waste	26.6	22.9	20.3	23	23.1	19.6
Total	33	29.6	32.1	35	35.7	31.9
Hours per Year - Fleet - Total	173,178	155,320	168,600	183,652	187,632	167,664
Hours per Year - Fleet - Ore	33,463	35,135	61,754	62,969	66,404	64,789
Hours per Year - Fleet - Waste	139,715	120,186	106,845	120,683	121,227	102,876
Number of Units - Rounded	33	30	32	35	36	32

Given the variations in the need for waste removal and in the average transport distances, from Year 2 of operation onwards, a more detailed study of the truck fleet to be acquired is recommended to review the possibility of outsourcing part of the waste to be removed, to stabilize the number of units of own trucks. Equipment demands for the following years and the need to renew equipment at the end of its useful life should be considered.

Pre-Feasibility Study

16.8.5 Mine Support Services

To support mining operations and mine infrastructure services, bulldozers, small-sized hydraulic excavator, motor graders, backhoe loaders, water trucks with a capacity of 20,000 liters will be used. Support trucks, forklifts, crane, mobile lighting towers and pick-up trucks will also be part of the support equipment and infrastructure fleet, which will be presented in the equipment Table 16-28 demonstrates fleet working hours and Table 16-29 shows the complete list of equipment required for the operation.

Maintenance work of the access points have the purpose of keeping the lanes in good conditions of trafficability and safety in operations. These services will be carried out in parallel with the mining activities. For the road coating, gravel will be used, removed in appropriate areas, preferably within the boundaries of the pit. In case of the unavailability of gravel in either quantity or quality, in the environmentally licensed operating limits, a mobile crushing and screening plant will be hired for crushing the waste rock part, to generate the gravel volume required for operations.

Table 16-28 Fleet worked hours per year per Equipment

Equipment	Shifts / day	Physical Availability (%)	Utilization (%)	Efficiency (%)	Worked Hour/year/unit
Hydraulic Excavator -70 t (2.8 – 4.5 m ³)	3	82%	82%	85%	5,007
Road Truck 42 t - 8x4	3	83%	85%	85%	5,253
Drilling Machine	3	82%	75%	80%	4,310
Wheel Loader (3.2 – 7.4 m ³)	3	80%	75%	65%	3,416
Bulldozer CAT D8	3	80%	75%	70%	3,679
Bulldozer CAT D6	3	80%	75%	70%	3,679
Wheel Dozer CAT 834H	3	80%	75%	70%	3,679
Grader	3	80%	70%	70%	3,434
Operation Support Truck - Scania	1	80%	75%	80%	1,402
Water Truck – 20,000 L	3	80%	60%	75%	3,154
Backhoe Excavator	2	80%	70%	70%	2,289
Hydraulic Excavator - 35 t with Hammer	3	80%	70%	60%	2,943
Forklift	1	85%	60%	70%	1,042
Blasting & Support Truck - Scania	1	80%	70%	70%	1,145
Fuel & Lube Truck – 8,000 L	2	80%	60%	80%	2,243
Maintenance Support Truck - Munck	1	80%	70%	80%	1,308
Crane - 30 t of capacity	1	85%	50%	80%	993
Portable lighting Tower	2	80%	60%	80%	2,243
Light Vehicle	3	75%	50%	60%	1,971

Pre-Feasibility Study

Table 16-29 Complete List of Equipment

Mining Fleet	Years										
	1	2	3	4	5	6	7	8	9	10	11
Hydraulic Excavator - 70 t (2.8 – 4.5 m ³)	11	12	13	13	12	8	7	7	7	7	6
Road Truck 42t - 8x4	34	43	52	48	46	33	30	32	35	36	32
Drilling Machine	11	11	12	12	12	8	7	6	7	7	6
Wheel Loader (3.2 – 7.4 m ³)	1	1	1	1	1	1	1	1	1	1	1
Bulldozer CAT D8	4	4	4	4	4	3	2	2	2	2	2
Bulldozer CAT D6	4	4	5	5	4	3	3	3	3	3	2
Wheel Dozer CAT 834H	2	2	3	3	2	2	1	1	1	1	1
Grader - Caterpillar	3	3	3	3	3	2	2	2	2	2	2
Operation Support Truck - Scania	3	3	3	3	3	2	2	2	2	2	2
Water Truck – 20,000 L	4	4	4	4	4	3	2	2	2	2	2
Backhoe Excavator	2	2	3	3	2	2	1	1	1	1	1
Hydraulic Excavator - 35 t with Hammer	2	2	3	3	2	2	1	1	1	1	1
Forklift	3	3	3	3	3	2	2	2	2	2	2
Blasting & Support Truck - Scania	3	3	3	3	3	2	2	2	2	2	2
Fuel & Lube Truck – 8,000 L	3	3	3	3	3	2	2	2	2	2	2
Maintenance Support Truck - Munck	3	3	3	3	3	2	2	2	2	2	2
Crane - 30 t of capacity	1	1	1	1	1	1	1	1	1	1	1
Portable Lighting Tower	8	8	9	9	8	6	5	5	5	5	4
Light Vehicle	6	6	7	7	6	4	4	4	4	4	3
Total	107	118	134	130	122	88	76	77	81	82	74

16.9 Hydrology

A combination of analytical estimates of groundwater inflow plus probabilistic hydrological (HMS-HEC) and water balance (GoldSim) modelling of the surface water regime has been applied to support the design of a pit dewatering system for life-of-mine (LOM). In-pit sump pumping systems have been sized to ensure that a total inflow equivalent to the maximum 20-year return frequency 24-hour event can be evacuated within a five-day period.

A surface water management system for both the open pit and waste rock dump (WRD) footprints has been designed based on predictions of LOM dewatering flows plus catchment hydrological modelling. Integral to the system is a series of perimeter channels which are proposed to restrict catchment runoff entry to the pits. The overall layout of the surface water conveyance system is designed to collect water from the pits and WRD for conveyance via settling ponds to the natural drainage network. Discharge points for the system have been defined such that the gradient of the natural topography is as low as possible at the point of release, thus minimizing scour potential.

Baseline water quality surveys, in conjunction with geochemical assays of ore and waste grade rock from Castelo de Sonhos, indicate that water pumped from the pits and/or generated through runoff and seepage from the WRD footprint will be chemically benign. No amendment will be required to these waters prior to discharge to natural surface watercourses except for removal of suspended particulate matter.

Pre-Feasibility Study**17 RECOVERY METHODS****17.1 Process Flowsheet and Basic Project Criteria**

Whole ore agitation leaching has been selected as the preferred process flowsheet for project development. The plant will be designed to treat 10,000 tonnes per day through crushing, grinding, hybrid cyanidation and carbon in leach, carbon acid wash, pressure stripping, and thermal regeneration. Gold will be electrowon from loaded eluate. Metal deposited on stainless steel wool cathodes will be rinsed off, decanted and collected as “sludge” which will be dried and smelted to produce doré bars for shipment to third party refiners. Figure 17-1 is the simplified flowsheet.

Pre-Feasibility Study

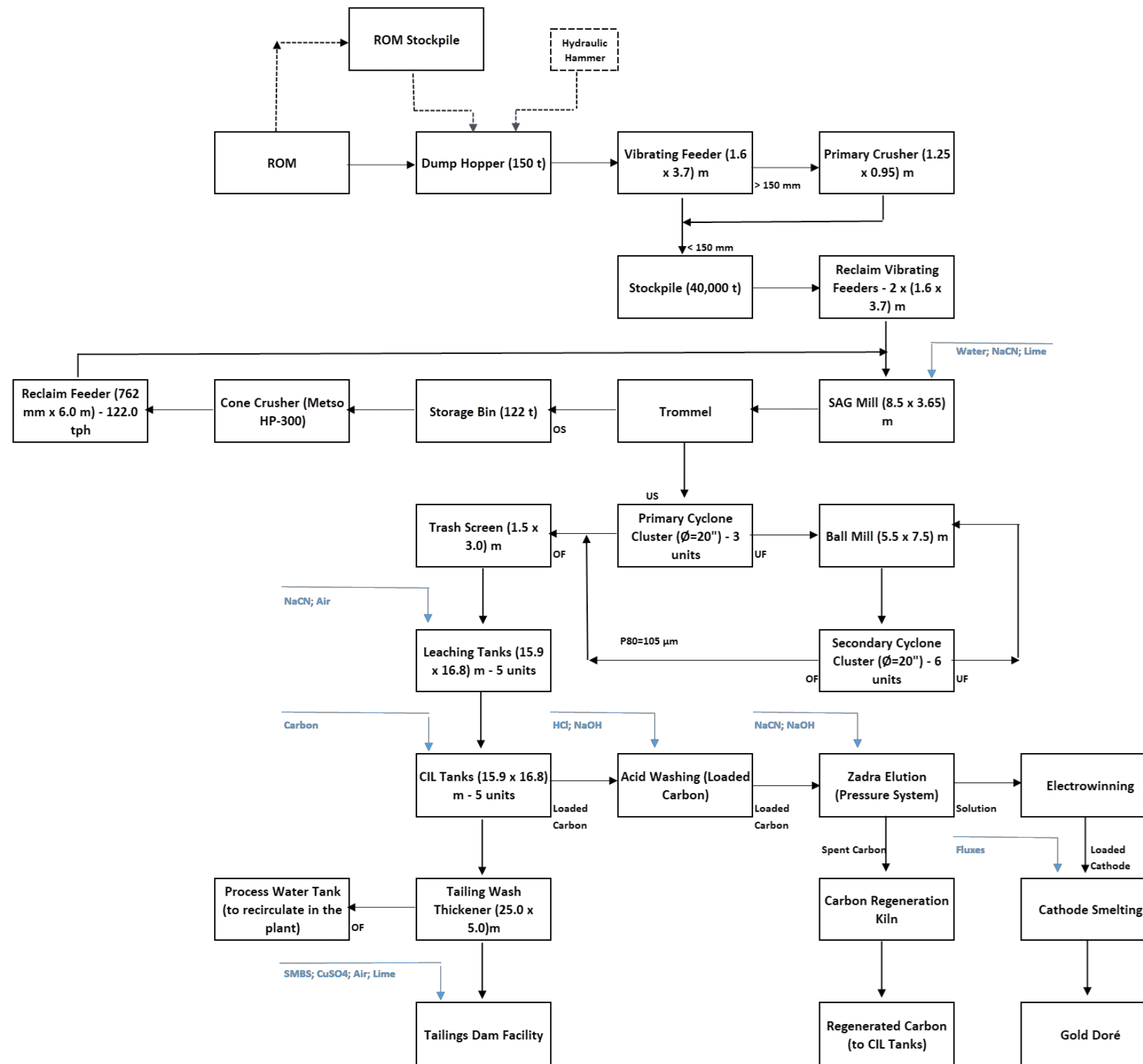

Figure 17-1 Simplified Block Diagram Proposed Flowsheet

Pre-Feasibility Study

17.1.1 Primary Crusher

10,000 dry metric tonnes per day. Twelve hours per day, seven days per week, 85% availability equals 980 dry metric tonnes per hour. Moisture content 2.5%. Primary crusher and coarse ore stockpile are represented in Figure 17-2.

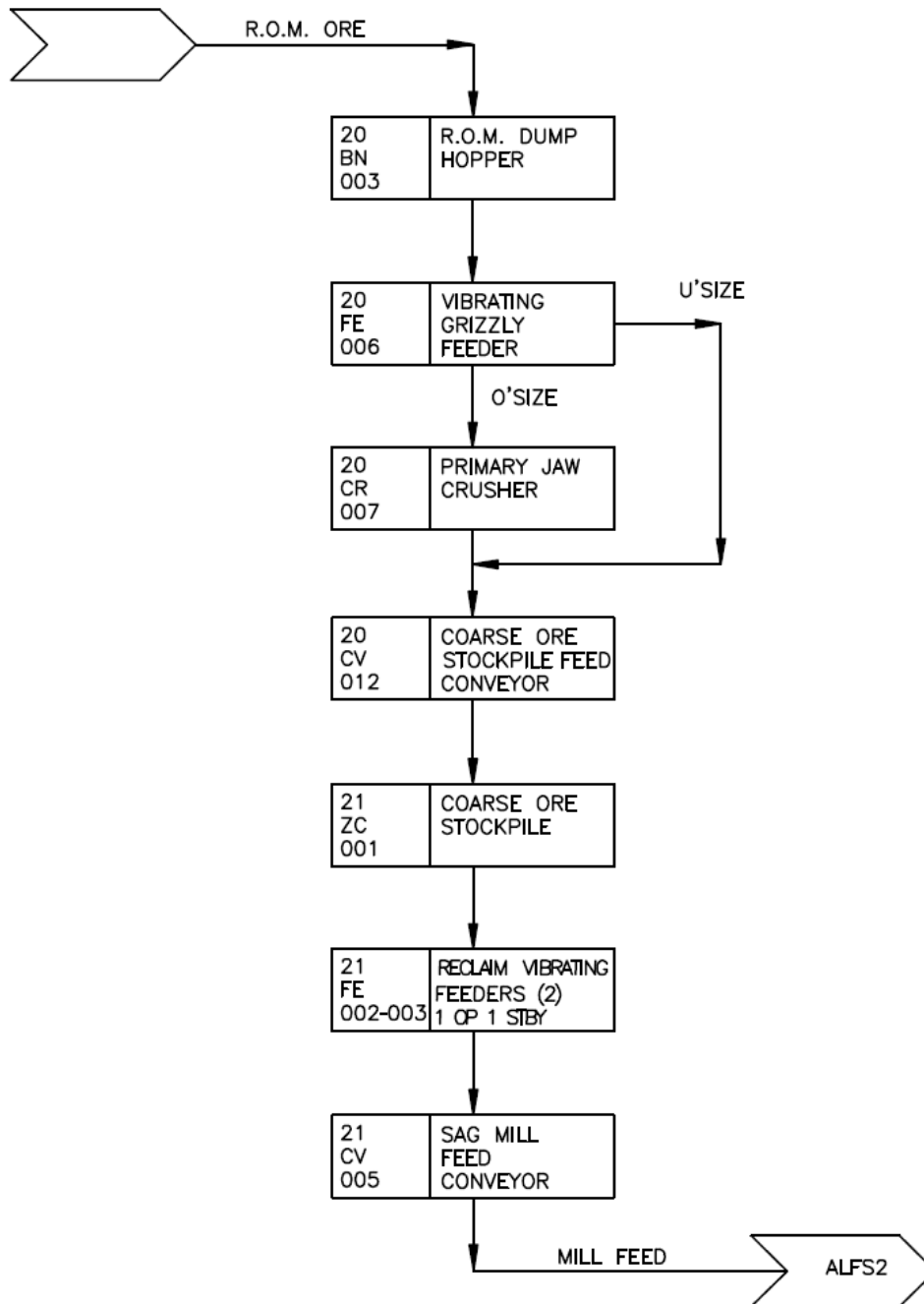

Figure 17-2 Simplified Conceptual Flowsheet - Primary Crushing and Coarse Ore Stockpile

Pre-Feasibility Study

17.1.2 Primary Stockpile

Nominally 40,000 tonnes total, with 10,000 tonnes effective capacity. Feed size 100% passing 300 mm 80% passing 150 mm.

17.1.3 Grinding

Final product to leaching $P_{80} = 105$ microns. Ball mill sized on testwork results (McClelland Laboratories, Sparks, Nevada USA). Bond Index (metric) 13.62, SAG mill sized on in-house data at 8 kWh per tonne.

Selected SAG mill 28ft (8.5 meters) diameter, 12 ft (3.6 meters) long, ball mill 18ft (5.5 meters) diameter, 25ft (7.5 meters) long, both with 3,750 kW motors (fixed speed drives) for common spare purposes.

Subsequent testing and analysis (Hazen Labs Golden, Colorado, USA 6 JK Simmet Red Bluff California USA) to produce $P_{80} = 150$ microns.

Suggests SAG mill 26ft (7.9 meters) diameter, 12 ft (3.7 meters) long 4,300 kW motor, ball mill 16ft (4.9 meters) diameter, 26ft (7.9 meters) long with 2,900 kW motor.

Trade off will be needed in detail design to compare $P_{80} = 105 \mu\text{m}$ vs $P_{80} = 150 \mu\text{m}$ and evaluate savings in grinding to coarser size against increased costs due to longer retention time in leach. Grinding and classification flowsheet is schematized in Figure 17-3.

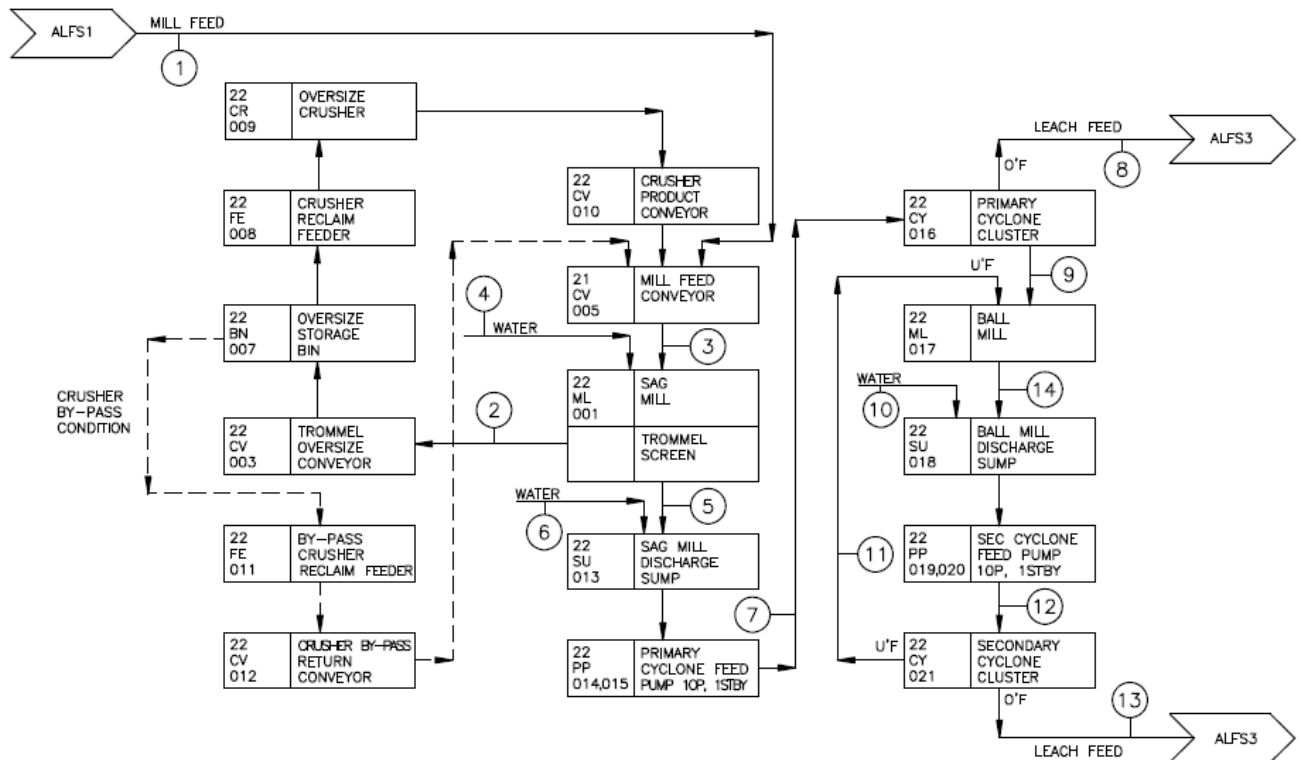

Figure 17-3 Simplified Conceptual Flowsheet – Grinding and Classification

17.1.4 Leach/CIL

Tanks sized on testwork results (McClelland Laboratories, Sparks, Nevada USA). Total residence time in leach and CIL (10 tanks) combined is 36 hours at 40% w/w slurry and $P_{80} = 105$ microns.

Pre-Feasibility Study

Carbon in leach 10 grams per liter of slurry, nominal gold loading on carbon 2,000 grams per tonne. Leaching and CIL scheme delineated in Figure 17-4.

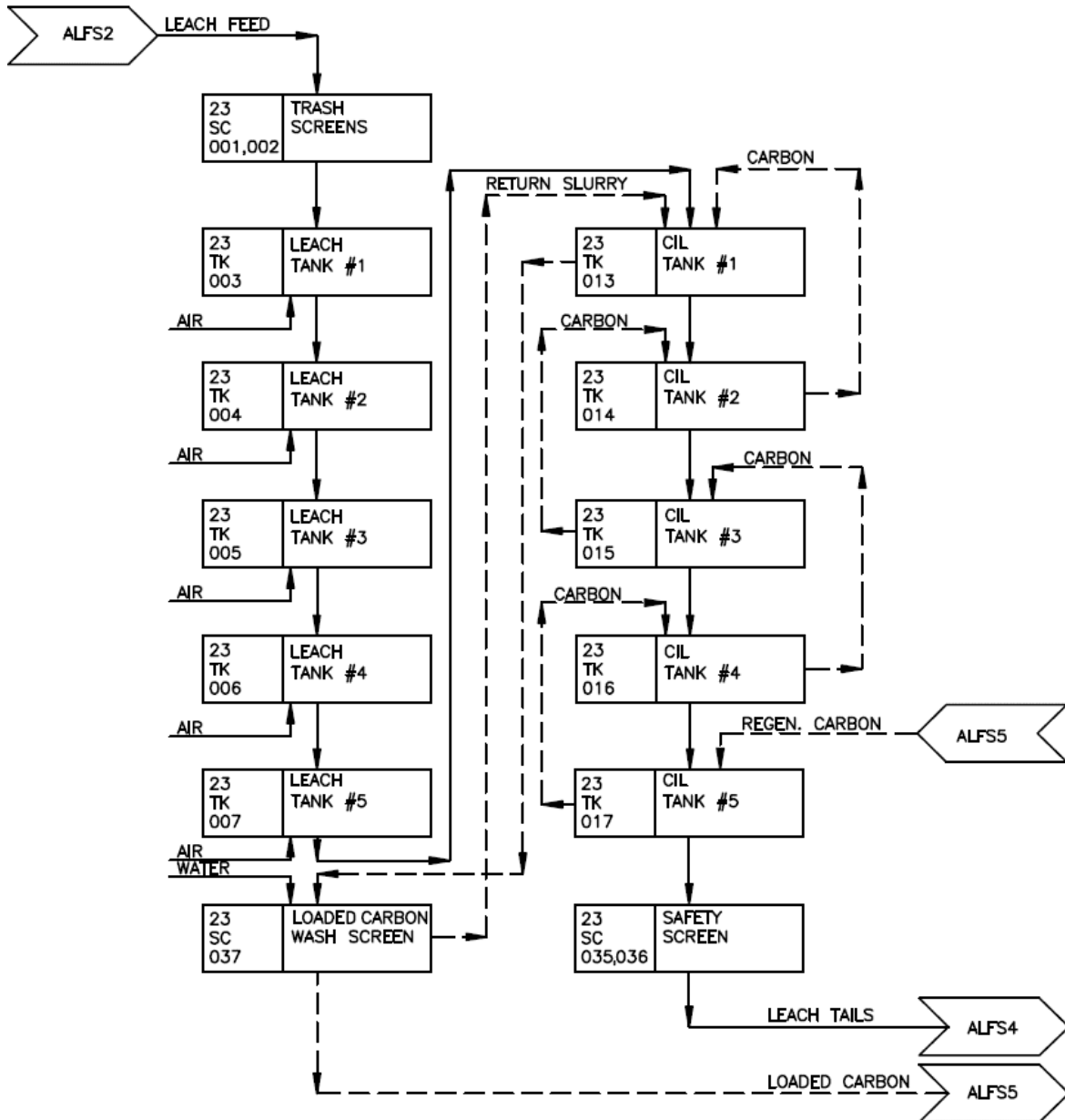

Figure 17-4 Simplified Conceptual Flowsheet – Leaching and CIL

17.1.5 Tailings Wash Thickener

Based on testwork by SLS-Pocock in Salt Lake City, Utah, USA, 25m diameter high-rate unit. Cyanide Destruction and Tailing Treatment diagram is presented in Figure 17-5.

Pre-Feasibility Study

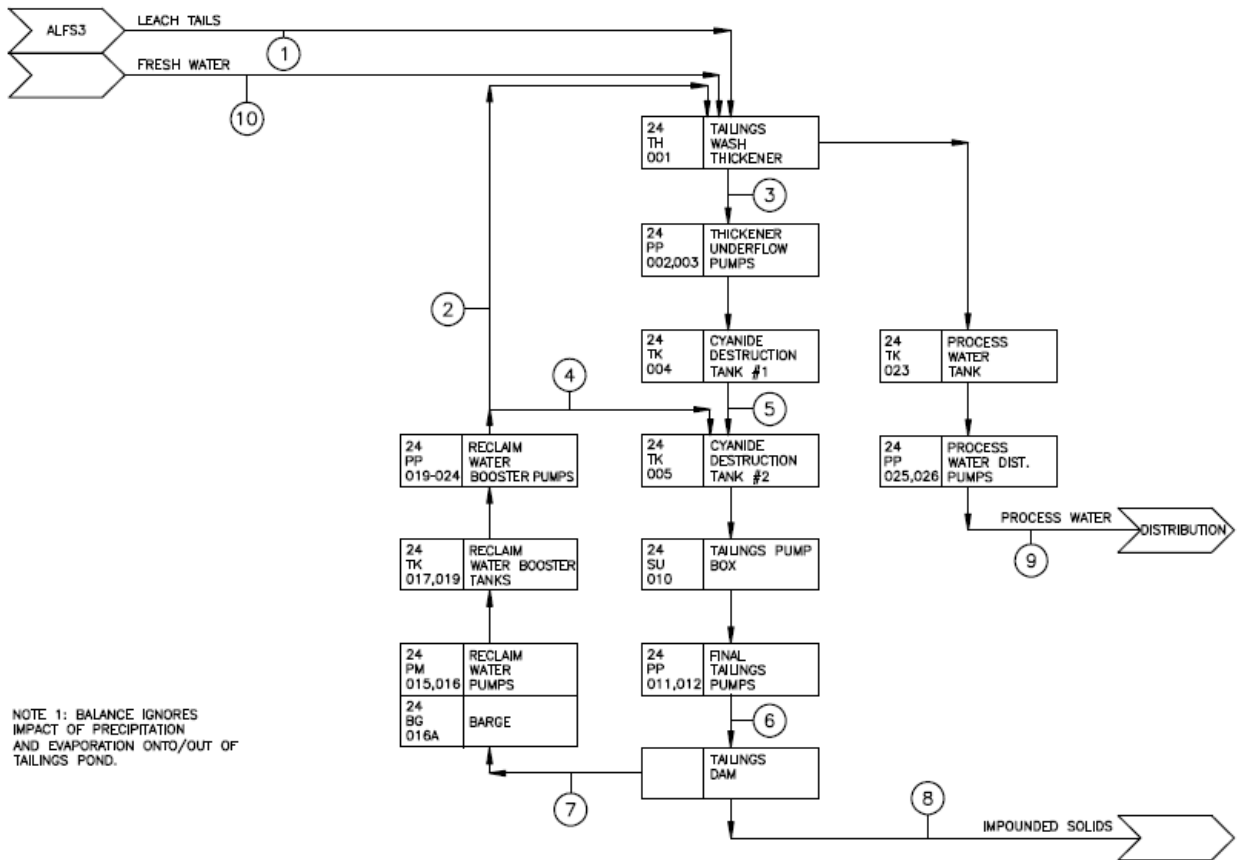

Figure 17-5 Simplified Conceptual Flowsheet – Cyanide Destruction and Tailing Treatment

17.1.6 Acid Washing and Carbon Regeneration

The loaded carbon stored in a bin is pumped to the acid washing, recovery of adsorbed gold and subsequent regeneration of the carbon and gold recovery by electrowinning. Acid Washing of Carbon and Electrowinning diagram is presented in Figure 17-6.

Pre-Feasibility Study

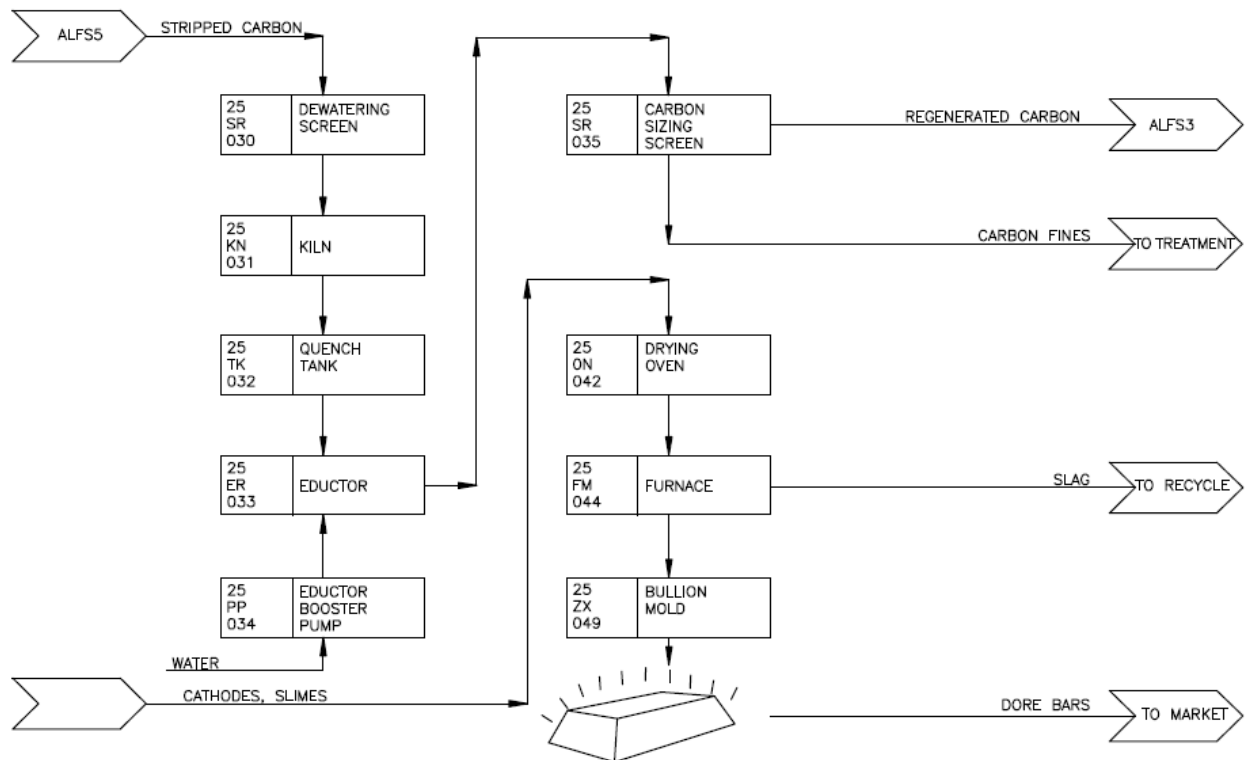

Figure 17-7 Simplified Conceptual Flowsheet – Carbon Regeneration and Smelting

17.2 Processing Plant Operations

A run of mine (“ROM”) stockpile area and the primary crusher dump hopper will be located adjacent to the Esperança South pit rim close to the centroid of the deposit. ROM ore will be hauled from the pit and either stockpiled for blending and/or subsequent reclamation by front end loader or direct dumped over a 400mm square opening stationary grizzly into the primary dump hopper, nominal capacity 150 tonnes. Sonic fogger dust suppression will be provided above the hopper. A rock pick mounted on the hopper will handle grizzly oversize. Ore will be withdrawn from the dump hopper with a vibrating grizzly feeder (1.6 x 3.7m with 150mm grizzly bar openings). Grizzly undersize will bypass the primary crusher, oversize feeds the primary crusher (1.25 x 0.95m jaw, set at 150mm).

Combined grizzly undersize and crusher discharge will be conveyed to a conical, uncovered, 40,000 tonnes total capacity coarse ore pile (live capacity nominally 10,000 tonnes, one day’s production). Ore will be reclaimed by two vibrating grizzly feeders (1.6 x 3.7m with 150mm grizzly bar openings) located in a tunnel beneath the pile.

The grinding circuit consists of an 8.5m diameter, 3.65m long (28 x 12 ft) fixed speed, 3,750 kilowatt semi autogenous (SAG) mill operating in closed circuit with a 200-kilowatt pebble crusher and (primary) cyclones followed by a 5.5m diameter, 7.5m long (18 x 25ft) fixed speed, 3,750 kilowatt, ball mill operating in closed circuit with (secondary) cyclones. Lime and sodium cyanide will be added to the SAG mill feed belt.

Combined primary and secondary cyclone overflows with P₈₀ of 105 microns (150 mesh) in a slurry containing 40% w/w solids, pass through vibrating trash screens which discharge to the

Pre-Feasibility Study

first of ten, 15.9m diameter x 16.8m high (52 x 55ft) cyanidation/CIL tanks operating in series for a total retention time of 36 hours. Air is injected into the first three leach tanks to promote gold dissolution and sodium cyanide solution is added to maintain a concentration of 1 g/l in leaching. The last five (CIL) tanks contain 10 g/t activated carbon. Intertank screens retain carbon in the CIL tanks, carbon is advanced through the circuit periodically by pumping slurry countercurrent to the normal slurry flow. Carbon remains in the recipient tank and slurry flows back downstream.

Loaded carbon containing nominally 2,000 g (65oz) of gold per tonne will be pumped out of the first CIL tank, discharged over a wash screen and advanced at the rate of eight tonnes per day to acid washing followed by elution in a pressure stripping system. Stripped carbon will be thermally regenerated in a gas fired rotary kiln operating at 1,200°F and returned to the fifth CIL tank.

Gold will be electrowon from loaded eluate in three, 750amp cells operating in parallel. Metal deposited on stainless steel wool cathodes will be rinsed off decanted and collected as “sludge” which will be dried and smelted to produce doré bars for shipment to third party refiners.

Leached slurry discharged from the last CIL tank passes through safety screens to recover carbon fines and flows by gravity to the leach discharge thickener where it is diluted with water reclaimed from the tailings pond. Thickener overflow containing approximately 60% of the sodium cyanide in thickener feed is returned to the grinding circuit. Thickener underflow is pumped to cyanide destruction where will be diluted to 40% w/w solids with reclaim water, mixed with sodium metabisulfite, copper sulfate and lime and subjected to intense agitation with low pressure air to destroy residual cyanide down to approximately 1ppm weak acid dissociable (“WAD”) cyanide.

Cyanide destruction circuit effluent will be pumped to the tailings dam constructed approximately 6km from the plant. Process water will be reclaimed with barge mounted pumps in the pond and returned to the process water storage tank at the plant site.

For the purposes of this study, it has been assumed that freshwater will be sourced from a well field close to the plant site. It may be necessary to change to a catchment dam across one of the drainages on site to store precipitation run-off for this purpose.

17.3 Reagents and Consumables Facility

Bulk handling systems will be provided for the receipt, storage, mixing and distribution of reagents and consumables. The reagents and consumables used in the process will be stored and prepared in a reagent facility, nearby the consumption plant.

The handling and storage of reagents and consumable items at the plant and other industrial facilities will be carried out strictly within the technical and safety regulatory standards of Brazil. Table 17-1 demonstrated reagents and consumables consumption.

Pre-Feasibility Study

Table 17-1 Reagents and Consumables Consumption

Category	Cons. Rate kg/ton	Annual Usage
Crusher Liners		
Primary	0.020	73 000
SAG Recycle	0.080	292 000
Mill Liners		
SAG	0.080	292 000
Ball	0.120	438 000
Grinding Media		
SAG	0.53	1 934 500
Ball	0.81	2 956 500
Reagents		
Cyanide		
- leaching (including loss to destruction)	0.22	803 000
- stripping	N/A	65 700
Lime		
- leaching	0.50	1 825 000
- CN destruction	1.05	3 832 500
Sodium Metabisulfite	0.55	2 007 500
Copper Sulfate	0.003	10 950
Flocculant (Tails Thickener)	0.02	73 000
Sodium Hydroxide (100% NaOH kg basis)	N/A	131 400
Hydrochloric Acid (20 Baume basis) liters	N/A	512 546
Carbon	0.05	182 500
Antiscalant	0.01	36 500
Propane		
- stripping (liters)		571 951

Sodium hydroxide (NaOH) will be delivered in road tanker lots, stored and distributed as a 50% w/w aqueous solution.

The consumption of soda is for treating carbon, including elution and acid washing. The product will be received and transferred to the storage and distribution tank (3.5m diameter x 4m high).

The solution is pumped to the consumption points at elution and acid washing. The total consumption, elution and acid washing, is around 175 kg/day (100% NaOH basis) or about 1.0 t of emulsion at 20% w/w. The capacity of the preparation/storage tank is sufficient to keep around 30 days of stocking.

Pre-Feasibility Study

Sodium cyanide (NaCN) will be delivered in road trucks, stored and distributed to the plant as a 30% w/w aqueous solution.

NaCN is a very toxic salt and special care will be taken in its storing and handling.

The product will be received in big-bags of 1 t each, wrapped in plastic and inside a wood box. They are disposed in a dedicated covered shed, equipped with NaCN gas detectors and security doors to prevent the entrance of unauthorized people.

The area is composed of a shed, with a capacity of 80 boxes and package residues, an agitated preparation tank and an agitated distribution tank. The preparation tank is equipped with bag-cutters on the top.

The big-bag is reclaimed from the shed by a forklift and delivered to the preparation tank (2.5m diameter x 3m high) area. The bag is unpacked by trained operators and lifted by electrical hoist to the top, where it is cut by the cutters and discharged in an alkalized water. After emptied, the bag is removed and stored in the shed for further destination.

The prepared solution in concentration of 30% w/w is stored in the distribution tank and pumped by dosing pumps to the consumption points (cyanidation and elution).

Hydrochloric acid (HCl) will be delivered in road tanker lots and stored as 22 Baume (33% w/w) aqueous solution. It will be diluted to 3% w/w concentration with raw water for use in the carbon stripping circuit.

The hydrochloric acid (HCl), 33% w/w, will be delivered in isotank trucks with a capacity of 20,000 l, and pumped to the storage tank (3.5m diameter x 4m high), with 38 m³ of capacity. The solution is pumped to consumption point in the acid washing of carbon.

Sodium metabisulfite (SMBS) is delivered in 1t capacity big bags and stored in the covered reagents shed. The bags are transferred to the preparation area using a forklift, and lifted to the top of the preparation tank by electrical hoists.

A 5% w/w emulsion is prepared in the agitated tank and pumped by dosing pumps to the detox area. The tank capacity (6.5m diameter x 7m high) is considering the daily consumption of 5.5 t and the solution at 5% w/w.

Antiscalant will be delivered to the plant by the supplier in reinforced plastic boxes, being stored in the shed.

Fresh activated carbon (6 x 16 mesh) will be delivered and stored in one tonne bulk bags.

The bags are stored on pallets, in an open area, paved with crushed stone. When required, the bags are transported by forklifts to the preparation tank, where they are lifted by hoist and discharged into an agitated tank.

Pre-Feasibility Study

Hydrated and pebble lime will be delivered in road trucks. Hydrated lime will be received in big bags with a capacity of 1 t and stored in a covered shed. A forklift transfers the bags to the preparation tank and, using an electric hoist, the bag is discharged in the preparation tank, where a 20% w/w emulsion is prepared and pumped to an agitated storage and distribution tank. This emulsion is distributed to the consumption points, in a ring-main by pumping. The continuous pumping prevents the sedimentation of the emulsion.

Copper sulfate (CuSO_4) will be delivered in 25 kg bags and stored in the reagents shed. The bags are transferred to a preparation tank, equipped with agitator, and a 5% w/w solution is pumped to the consumption points.

Flocculant will be delivered in powder, packaged in 25 kg bags and prepared in a conditioning tank, at a concentration of 5% w/w, and pumped to dosing pumps to the thickener.

Grinding media (ball mill and SAG mill) will be delivered in bulk bags and stored in concrete wall pens close to the grinding mills.

Mill liners (ball mill and SAG mill) will be delivered in bulk bags and stored in concrete wall pens close to the grinding mills.

17.4 Freshwater Catchment and Distribution System

The freshwater is pumped from wells to the potable water and fire suppression systems. This system consists of sulphate of the following procedure.

The process water is recovered from the tailings dam, where pumps installed in a barge, reclaim the supernatant clean water, pumping it back to the plant. The freshwater system equipment was estimated based on the consumption and recoveries indicated in the following and recoveries.

17.5 Ancillary Facilities

The ancillary facilities are maintenance, laboratory, security/fire station, fuel system, administration building and compressed air facility.

- **Maintenance Facility:** a complete maintenance building will be constructed to attend to the requirements of process and mine equipment.
- **Laboratory Facility:** a complete laboratory building will be constructed to attend to the requirements of plant and mine. The laboratory will have equipment for sample preparation and physical and chemical analysis of mine and plant samples. The laboratory facility consists of a building and bench scale equipment.
- **Security/Fire Station:** The security/fire facility consists of a building, equipment and vehicles for fighting and preventing fires and providing first aid in case of accidents in industrial operations.

Pre-Feasibility Study

- **Fuel System Facility:** The fuel installation is made up of gasoline and diesel storage tanks, which have distribution and consumption control equipment for these fuels.
- **Compressed Air Facility:** a complete compressed air facility will be constructed to attend to the requirements of process and utilities. The air is transferred to the consumption points by pipes and control valves.

17.6 Power Distribution

The supply of electricity is described in more detail in the Project Infrastructure Chapter of this report. A distribution system is available at the plant site. The distribution system consists of an electric power distribution station and a diesel electric power generator to prevent emergencies.

17.6.1 Preliminary Conceptual Plant Layout

Figure 17-8 shows a conceptual layout of the plant that was made according to the flowsheet and basic design criteria adopted so far.

Pre-Feasibility Study

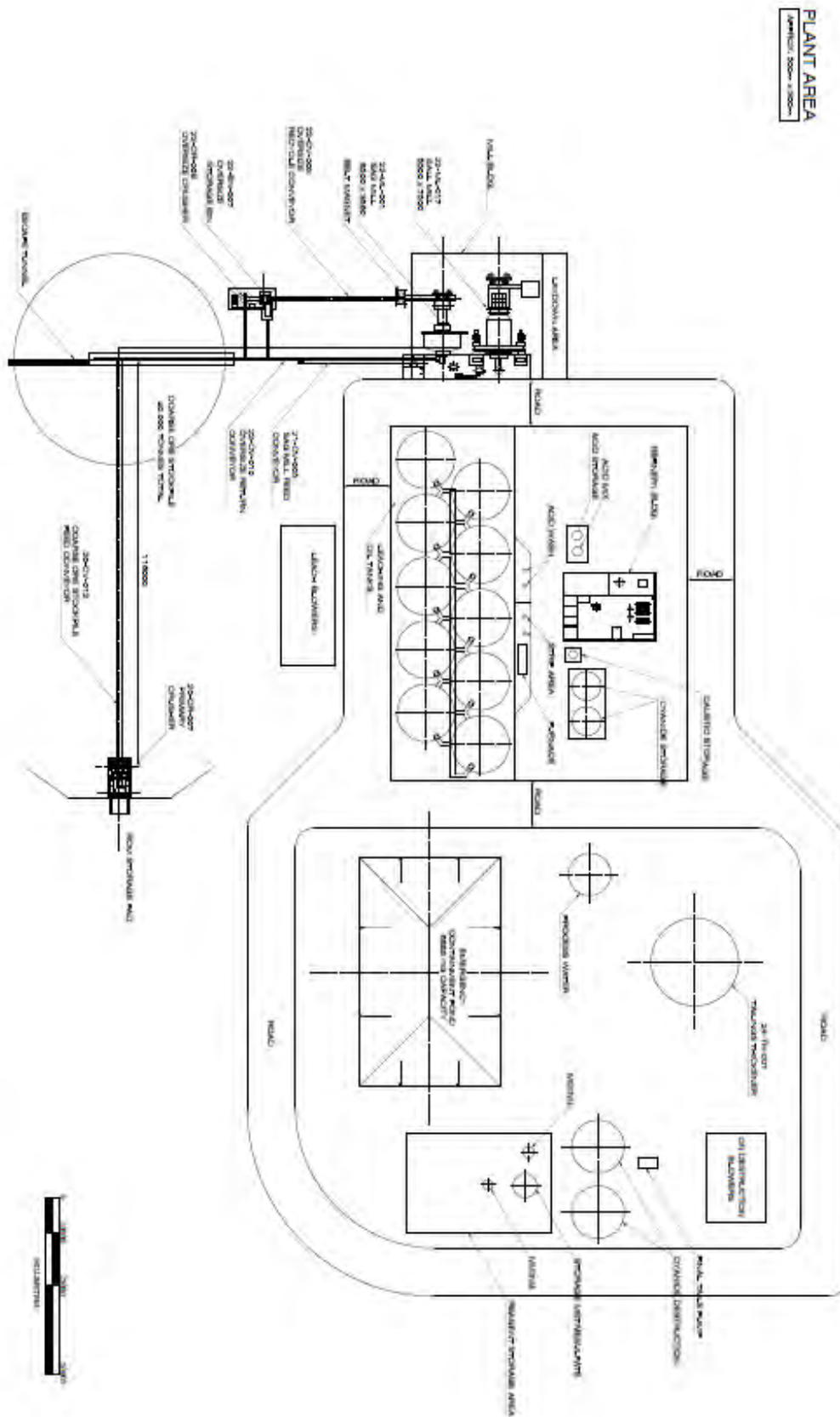

Figure 17-8 Preliminary Conceptual Plant Layout

Pre-Feasibility Study**18 PROJECT INFRASTRUCTURE**

The infrastructure requirements for the Project are summarized in the following sections and are incorporated into the capital cost estimate for the Project.

18.1 Explosive Magazine

Ammonium nitrate emulsion is stored at the site, while blasting caps and accessories are delivered on a just-in-time basis. This material will be stored near the plant facility site following international and security guidelines.

18.2 Waste Dump

The waste dumps have been designed to optimally use the site topography to allow for safe drainage, and short haul distances. The berms were designed to work as drainage systems for rainwater, despite the high permeability of the landfill. In the longitudinal direction, the berms have a slope of 1%. This inclination allows the flow of water to the peripheral channels. In cross section, the berms should have a dip of 5% towards the foot of the upper slope. Figure 18-1 illustrates waste piles layout.

Pre-Feasibility Study

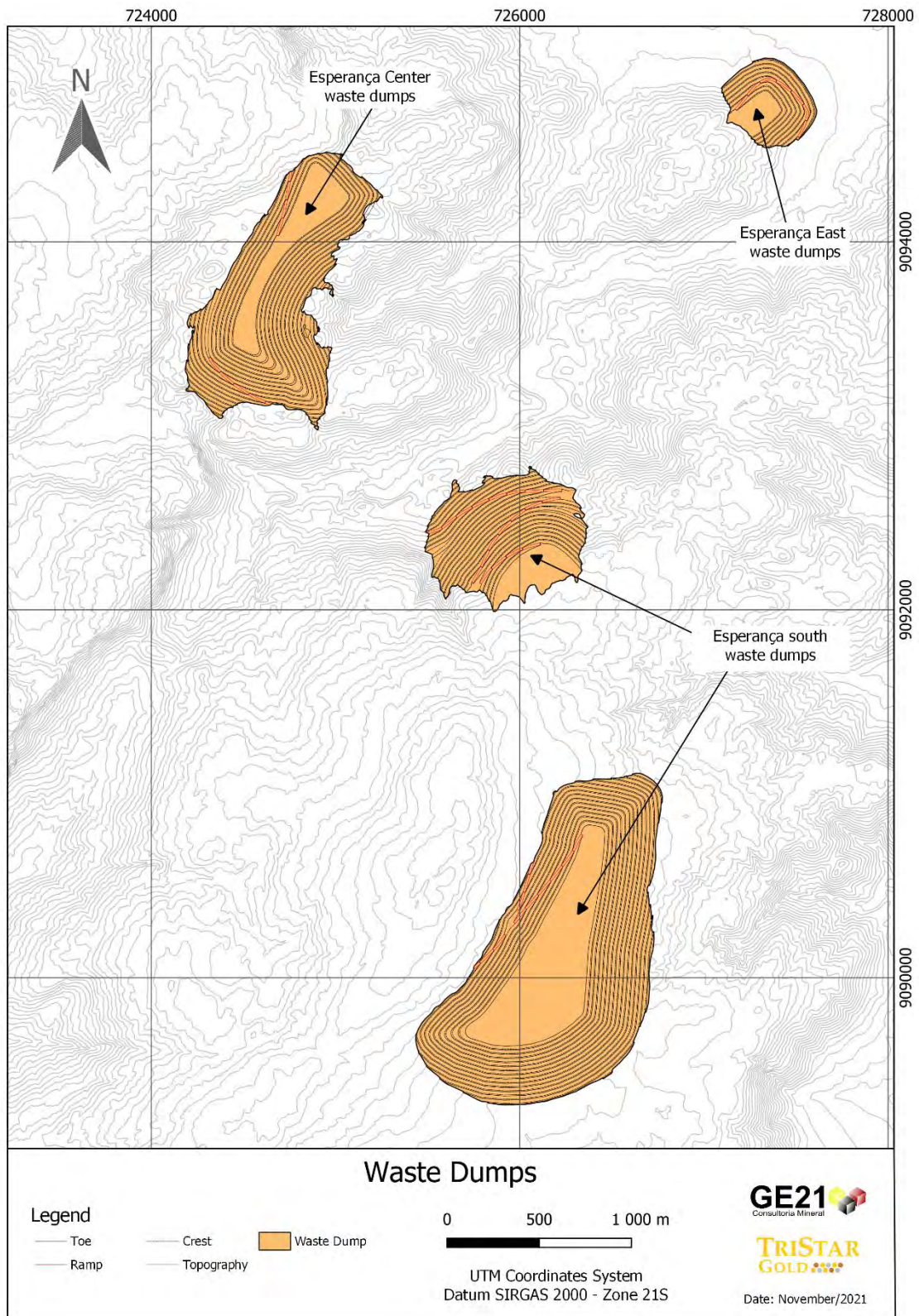

Figure 18-1 Waste Piles Layout for Castelo de Sonhos Project

Pre-Feasibility Study

18.3 Tailings Facilities

A PFS level design has been developed for a conventional TSF site located in a valley on the property as presented in Figure 18-2. Site selection was chosen following screening of a series of four alternative locations, plus the technical and economic trade-off of wet deposition versus thickened tailings ('dry-stack') disposal options.

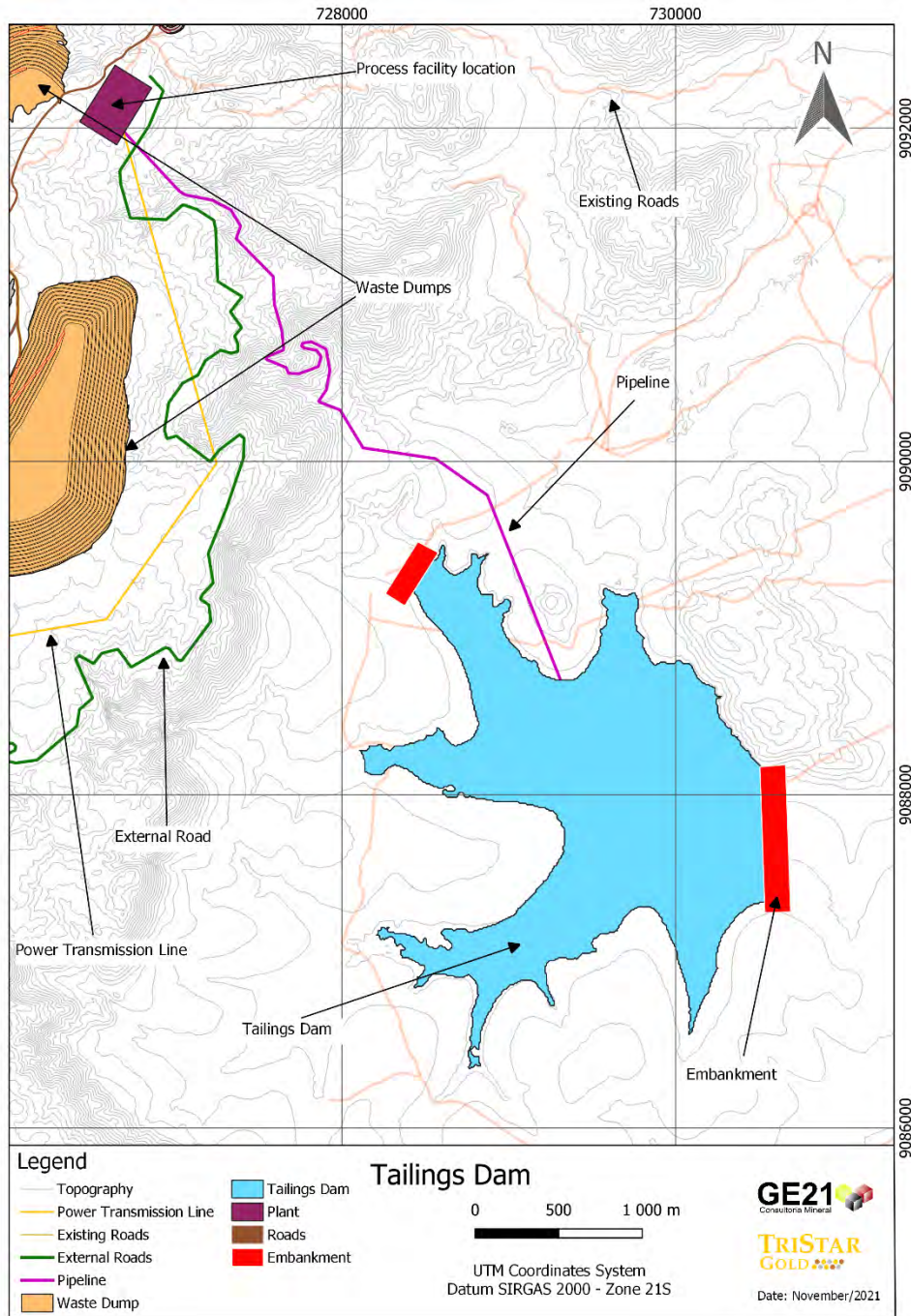

Figure 18-2: Tailing Storage Facility Design

Pre-Feasibility Study

The TSF will ultimately occupy an area of 367ha. It is designed to accommodate 39 Mt of tailings with an in-situ density of 1.55 t/m³.

A construction schedule and cost estimate for the TSF has been developed based on construction in two phases. The Phase 1 embankment crest elevation will be 281 mRL, providing 14 Mt of consolidated tailings storage. Phase 2 will increase the elevation to 290 mRL and will increase the capacity to 39 Mt. On completion of Phase 2, the ultimate embankment height will be a 26 m above ground level. In accordance with industry best practice the embankment raise for Phase 2 will utilize a downstream construction method with slope angles of 1V:3H. The main embankment of the TSF is to be constructed of a downstream semipermeable medium, an upstream clay core and an intervening inert rockfill blanket drain. The embankment design includes an upstream seepage cut-off trench from which any collected solution will be returned to the main TSF pond.

Tailings in the form of slurry will be discharged sub-aerially via multiple spigot points located along the embankment. The spigot layout is designed to maintain a supernatant pond in the south-west sector of the basin and to develop beaches of a nominal 0.5 % gradient in the east and north-east sectors. Control of the TSF pond will be maintained using a land-based pump array with an intake mounted on a barge. For operational process make-up security, a target pond inventory of 1.5 Mm³ will be maintained. Under all circumstances in which this threshold is exceeded, extraction at rates necessary to meet process plant demands will be supplemented by pumping of excess water for environmental discharge. In conjunction, these flows require an installed pumping capacity of approximately 1,000 m³/hr. Throughout the period of active TSF operations, free-board will be maintained to accommodate the probable maximum flood event.

The PFS embankment design for the TSF has been subject to both seepage and geotechnical stability analysis, the latter of which was conducted to establish static and dynamic limit-equilibrium stability indices. For the Phase 2 crest height, static and dynamic loadings equivalent to the 475-year recurrence interval seismic event (corresponding to a 10% probability of exceedance in 50 years) were applied. Under drained conditions, the static factor of safety (FOS) defined for the Phase 2 embankment is estimated by limit-equilibrium modelling to be 1.86. This significantly exceeds the 1.5 FOS threshold adopted as a design criterion. This FOS is reduced only nominally (to 1.82) under dynamic loading conditions of the magnitude specified above. In undrained state the FOS is reduced to 1.17 but remains in excess of the required FOS criterion of 1.1.

18.4 Camp Accommodation

There is an existing camp at the project that supports approximately forty people. The facilities at site include laundry, dorms, kitchen, warehouse, exploration office and generator house. The camp is connected to grid power, with a generator available to cover for any power outages.

During the construction period, the camp will be expanded to accommodate the owner's visitors and consultants, and a first-aid facility and quarantine accommodation will be built near the main camp offices.

Pre-Feasibility Study**18.5 Site Infrastructure****18.5.1 Mine dewatering and conveyance**

Annual precipitation at Castelo de Sonhos has ranged from 1,677mm and 2,968 mm over a 50-year recording period from 1971 to 2021. The principal source of water inflow to the pits will be direct precipitation and pit wall runoff, plus any inflow of runoff from surrounding areas. Minor seepage of groundwater may also occur through the pit walls. In general, this is expected to represent a negligible component of total pit inflow although potential for increased flows may exist when specific structures (fault/fractures) are intersected during pit development.

Due to the position of Castelo de Sonhos on a plateau, both the bedrock and weathered zone aquifer units lack any substantive hydraulic connection to the regional-scale groundwater system. Effective recharge and aquifer storage in the area influencing the pits may thus be defined with a high level of confidence.

The Hydrologic Modeling System (HMS) software developed by the Hydrologic Engineering Center (HEC) of the US Army Corps of Engineers has been used to develop a combination of analytical estimates of groundwater inflow plus probabilistic hydrological and water balance modelling of the surface water has been applied to support the design of a pit dewatering system for life-of-mine. In-pit sump pumping systems have been sized to ensure that a total inflow equivalent to the maximum 20-year return frequency 24-hour event can be evacuated within a five-day period. For the largest individual pit in the final phase of development, this equates to a pumping capacity of 468 m³/hr. The vertical lift for the pumping systems will, at a maximum, be approximately 134 m. Based on the current proposed sequencing of pit development, and the assumption that dewatering will be restricted to actively mined pits, a site-wide requirement has been established for two pumps with a 350 m³/hr capacity and a total dynamic head of 150 m plus two pumps of 200 m³/hr capacity and with a 70 m total dynamic head.

The host rock units of the pit areas are amenable to relatively free drainage with little potential for localized pore pressure induction or associated pit slope instability. It is anticipated that dewatering can be conducted passively from the pit sumps and that no major cost provision will be required for peripheral well installations of horizontal drains.

A surface water management system for both the open pit and waste rock dump (WRD) footprints has been designed based on predictions of LOM dewatering flows plus hydrological catchment modelling. Integral to the system is a series of perimeter channels which are proposed to restrict catchment runoff entry to the pits. The perimeter channels are designed to convey the 50-year return period maximum 24-hour runoff. The overall layout of the surface water conveyance system is designed to collect water from the pits and WRD for conveyance via settling ponds to the natural drainage network. Discharge points for the system have been designed such that the gradient of the natural topography is as low as possible at the point of release, thus minimizing scour potential. The total channel length within the layout is approximately 9.2 km.

Baseline water quality surveys, in conjunction with geochemical assays of ore and waste grade rock from the Project, indicate that water pumped from the pits and/or generated through runoff

Pre-Feasibility Study

and seepage from the WRD footprint will be chemically benign. Operational pit sump water and waste rock facility runoff/seepage is predicted to be of near-neutral pH with total dissolved solids (TDS) levels of <200 mg/l and extremely low concentrations of metals. No amendment will be required to these waters prior to discharge to natural surface watercourses except for removal of suspended particulate matter.

18.5.2 Potable Water

In addition to the process water, a potable water requirement of 10 m³/d is estimated. The supply for this water can also be derived from the storage water pond and would be subject to testing and appropriate treatment (chlorination).

18.5.3 Water Supply

A site-wide probabilistic water balance model has been designed for Castelo de Sonhos using the industry-standard software GoldSim. Results of model simulations confirm that the water balance will be net-positive. A source of fresh-water supply for the process and/or for ancillary uses (fire, dust suppression, potable supply etc.) must nonetheless be established for contingency, or for those uses requiring a strictly prescribed chemical quality.

The process and tailings storage facility (TSF) water balance has been simulated for the projected LOM mill feed rate of 4 Mtpa and a discharged tailings slurry of 50% solids by mass. The total process plant water requirement will be around 463 m³/h on this basis. At mine start-up a raw water supply to cover all demand minus a small volume of water held as ore moisture will be required. This demand will rapidly diminish (within a few months) as the TSF supernatant pond becomes established. Subsequently, process demand for raw water will be reduced to a nominal 14 l/s (50 m³/h) which corresponds to fresh water strictly required for reagent preparation and gland seals. All process demand is otherwise predicted by the GoldSim model to be available through TSF reclaim. Probabilistic simulations conducted for 100 x LOM daily resolution realizations produced only one instance in which TSF reclaim would be inadequate to satisfy this demand, resulting in a temporary increase of raw water intake to the process of the order of 40 l/s.

Irrespective of the use of TSF reclaim as process supply, significant year-on-year build of water inventory will occur on the TSF in the absence of a pathway for the release of excess water. The facility is predicted to be subject to a net positive balance of the order of 3 to 4 Mm³/yr., which will require management through controlled abstraction of between 100 and 150 l/s via a barge pump. This water will be discharged to the natural surface drainage system, subject to compliance with all applicable water quality criteria.

A water quality model has been integrated into the GoldSim physical water balance for the TSF to determine the level of compliance with statutory effluent criteria anticipated in the excess TSF water stream. Results of modelling confirm that there is no substantive risk of exceedance of internationally established effluent guidelines (including IFC standards) for TDS or metals. WAD cyanide compliance will be achieved subject to the operation of the cyanide detoxification (SO₂-

Pre-Feasibility Study

air) system included in the process plant flow sheet to a constant residual WAD CN level of <1 mg/l in the tailing's slurry.

18.5.4 Sewage Treatment

One sewage treatment plant will be used to process sewage from the industrial areas. This plant is compact in size and the treated effluent will be used for garden maintenance and dust control on roads.

18.5.5 Airstrip

There are currently two airstrips at site, one is 550 m in length by 30 m wide, and the other is 500 m in length by 20 m wide. The airstrips are suitable for helicopter landing as well as a single engine airplane (6 seaters).

18.5.6 Communication

The communications systems will include internet, radio communication, telephone with all necessary hardware, software, data, and procedures required to generate information to support day to day operations.

18.6 Buildings**18.6.1 Administration Building**

The administration building will be of a single-storey cinder block construction and will contain general areas for the onsite engineering and geology teams as well as space for administration personnel, offices for the general manager, mine manager, plant manager, chief engineer, chief geologist, EH&S and medical care room.

The design of these buildings considered the local climate, environmental aspects, ergonomics, durability, standards and appropriate building codes for a project of this size.

18.6.2 Maintenance Facility

The maintenance facility building will be placed nearby the plant facility and will include four truck repair bays of approximately 36 m x 12 m x 12 m eave height. A warehouse with dimensions of 36 m x 10 m x 7.5 m eave height, a maintenance shop with 27 m x 10 m x 7.5 m eave height, it will be constructed of a steel frame and be non-insulated.

18.6.3 Fuel and Lubricant Storage and Distribution

Diesel fuel will be delivered to the site by road tankers. Fuel distribution is limited to loading and unloading facilities. Also, a diesel fuel storage tank for the open pit operations will be located on site. Diesel storage is planned to have 378.5 m³ capacity in carbon steel tanks.

Lubricants will be delivered to the site in drums. The drums will be stored in a secure area in accordance with state regulations.

Pre-Feasibility Study**18.6.4 Air**

Compressors will be supplying high-pressure air for instruments, plant general use, and tanks. This equipment will be appropriately stored in a compressor building.

18.6.5 Assay Laboratory

A fully equipped assay laboratory will be located at the plant site. The laboratory will deliver analysis of mining and process samples as needed.

18.6.6 Security Building

The high security building will be constructed of a single storey prefabricated building, the gold production will leave the project by helicopter or light aircraft.

18.6.7 Miscellaneous Buildings

A main gatehouse will be located at the entrance to the plant site. This building will have a single-story cinder block structure and will also include a treatment center. The gatehouse will be equipped with first aid facilities.

18.7 Site Access**18.7.1 Site Access Road**

Castelo de Sonhos Village is located approximately 20 km from the Castelo de Sonhos Project. The main access site road will require an upgrade of 2 km from the existing road and the construction of a 15.6 km extension road, 8 m wide connecting the existing road to the process facility.

18.7.2 Site Roads

Site roads are designed to connect facilities in the mine and processing area. The following roads have been anticipated:

- Mine Haulage access road: The road will connect the mine to waste dumps and process plant. It will have 12 m width and maximum 10 % inclination.
- Makeup water access road: 2.6 km long projected for an upgrade on an existing road.
- Pipelines from metallurgical plant to dam access road: 5.6 km long and 5 m wide.

18.8 Power Supply

The estimated electrical power demand for the project is 15 MW. The electricity supply condition for the region where the Project is located is connected to a 138 kV system from the state of Mato Grosso, and the nearest 138 kV substation is the Castelo de Sonhos substation, located approximately 20 km south of the project.

Pre-Feasibility Study

Three power line options were studied for the Project taking into consideration the technical and environmental aspects. The power line route option chosen has a length of 27 km and 20 m width safety strip. Project connection is conceived to be as followed:

- 138 kV exit bay at Castelo de Sonhos substation;
- 27 km of 138 kV transmission line, single circuit, conductor cable MCM 336.4 (Linnet) for a 16 MVA power transport;
- Project Main Substation with 138 – 13.8 kV transformation.

The existing system in the region can deliver the necessary power for the project operation.

18.8.1 Future Expansion

As part of the Brazilian power system transmission expansion, the Federal Government, through ANEEL, the Electricity Regulatory Agency and Granting Agent, has given concession to the construction of a 230 kV transmission line to reach Novo Progresso substation which will become a 230/138 kV substation. According to the Concession Contract, signed in March 2020, this 230 kV system with power line and substation should begin operation in March 2025.

The increase in the transmission power line substation in Castelo de Sonhos to 230 kV/138 kV can benefit the Project although the existing connected grid is sufficient for project requirements.

18.9 Project Layout

The Figure 18-3 presents the Conceptual Master Plan for the Castelo de Sonhos Project.

Pre-Feasibility Study

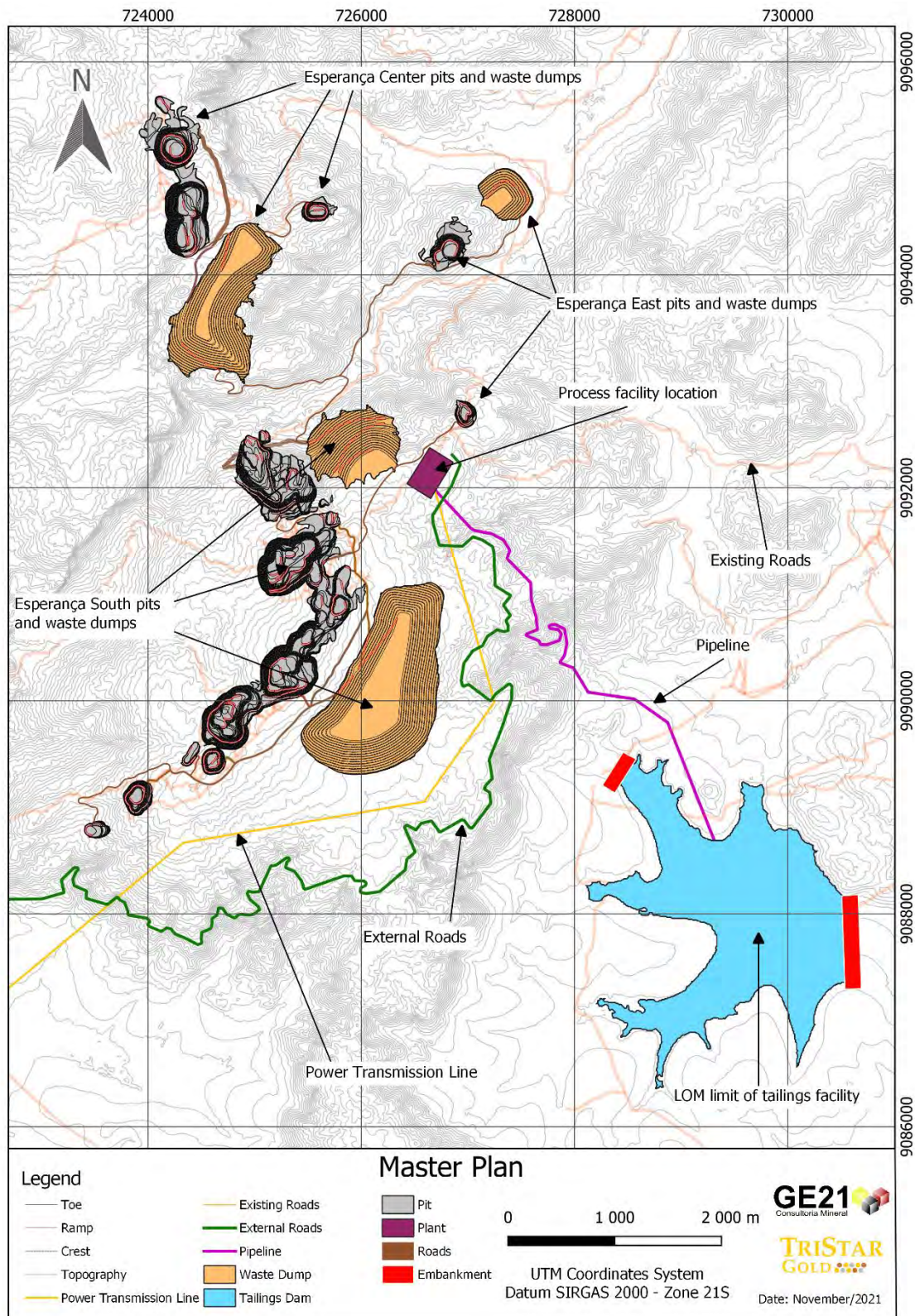

Figure 18-3 Project Layout

Pre-Feasibility Study**19 MARKET STUDY AND CONTRACTS****19.1 Market Study**

A formal gold market study was not developed for this technical report. For the Economic Model, GE21 used the value of \$ 1550/oz based on recent gold projects Technical Reports.

19.2 Refining, Transportation, and Insurance

Refining, transportation, and insurance of US\$ 13/oz has been considered for this technical report.

Pre-Feasibility Study

**20 ENVIRONMENTAL STUDIES, PERMITTING AND SOCIAL OR
COMMUNITY IMPACT****20.1 Overview of Regulatory Framework for Environmental Licensing**

In Brazil, the process of environmental licensing is decentralized. Any activity that might impact the environment must conform to the Brazilian federal government's National Environment Policy and obtain the proper licenses. The National Environmental Council (Conselho Nacional do Meio Ambiente: CONAMA) is the federal agency that has the power to pass nationwide environmental regulations. For mining activities, CONAMA has established an environmental licensing process that must be followed throughout the country; but it falls to other federal, state and municipal agencies to be the responsible authorities that review license applications and decide whether or not to grant the licenses. In the case of TriStar's Castelo de Sonhos Project, the responsible authority is Pará State's State Secretariat of the Environment and Sustainability (Secretaria de Estado de Meio Ambiente e Sustentabilidade: SEMAS).

Three licenses are required by mining projects in Brazil:

- Preliminary License (Licença Prévia: LP)
- Construction or Installation License (Licença de Instalação: LI)
- Operating License (Licença de Operação: LO)

These licenses are sequential: the LP must be obtained before an application for the LI can be made; the LI must be obtained before an application for the LO can be made; and the LO must be obtained before a mine can go into production.

Preliminary License: The LP evaluates the environmental feasibility of a proposed mining project. If the application is in accordance with environmental legislation and requirements, the LI then ratifies the project's location, scale and implementation plan, and establishes basic requirements and conditions to be met in the project's next stages. Three documents must be filed to support the LP application for a mining project:

- Environmental Impact Assessment (EIA)
- Report on Environmental Impact (Relatório de Impacto Ambiental: RIMA)
- Plan for the Recovery of Degraded Areas (abbreviated as PRAD in Portuguese)

Together, the EIA and the RIMA provide the information that will be used by the responsible authority to decide whether or not to grant the LP. The EIA is a technical/ scientific report, while the RIMA is a public consultancy document, written in simple and clear language for non-experts, that aims to acquaint the local community and stakeholders with the project and its potential impacts. Well before applying for a Preliminary License, the applicant receives from the responsible authority the Terms of Reference for the EIA/RIMA which are project-specific regulations that provide general guidelines for technical activities, define the affected areas, and

Pre-Feasibility Study

specify field studies and data collection that must be planned and executed by a qualified multidisciplinary team, independent of the applicant.

Installation License: The LI authorizes the construction of the mine's infrastructure in accordance with the specifications contained in the implementation plan ratified by the Preliminary License, including measures for environmental monitoring and for mitigating adverse environmental effects. An Environment Control Plan (Plano de Controle Ambiental: PCA) must be filed in support of the LI application. This document sets forth all measures that will be taken to reduce negative environmental impacts and to improve positive impacts and must be consistent with the EIA and RIMA reports accepted and approved for the Preliminary License.

Operating License: An LO is required before a mine extracts, processes or sells any commodity. It is issued after the responsible authority has inspected the mine infrastructure, has confirmed that all required monitoring systems are operational, and has verified that all measures designed to mitigate environmental impact have been properly implemented.

Other Licenses: Permits for capturing surface and groundwater as well as for the discharge of effluents into the water body within legal standards must be requested from the environmental agency. In areas of installation of structures defined by EIA or Environment Control Report (RCA) and Environment Control Plan (PCA), a Vegetation Suppression Authorization - ASV must also be requested.

20.2 Environmental Permitting Activities 2020/2021

Socio-environmental baseline studies are in progress at site. Fieldwork including flora and fauna studies, archaeological and speleological (caving), air, noise & vibration as well as hydrology and hydrogeological monitoring and geochemistry analyses are ongoing. Chronological highlights of these activities are summarized below:

In March 2020 - SEMAS issues the Terms of Reference for the EIA/RIMA for the Castelo de Sonhos Project. With the Terms in place, TriStar and its EIA team begin planning baseline studies, most of which require data to be gathered over a one-year period that cycles through seasonal fluctuations.

August 2020 – A high-resolution aerial photography and LIDAR topography survey was done of the project site and surrounding area to support detailed mapping for future EIA and licensing activities.

September 2020 - Environmental Manager contracted to oversee EIA activities, facilitate regulator engagement, and address issues related to land and social engagement. Study completed to catalogue environmental considerations arising from the Economic Utilization Plan, Plano de Aproveitamento Econômico (PAE), submitted for four of the project's mineral concessions. Scope and deliverables proposed by environmental consultants were reviewed and assessed, and appropriate consultants were contracted to form the independent EIA team, with SETE Soluções e Tecnologia Ambiental to coordinate the EIA and to perform many of its environmental and socio-economic studies

Pre-Feasibility Study

January 2021 - First monitoring wells drilled. Socio-economic team initiates stakeholder mapping for the areas affected by the project. Physical environment studies on CDS plateau initiated. Rainy season data on air, noise and vibration gathered.

February 2021 - Three monitoring wells drilled and piezometers installed. Wet season surface and groundwater samples collected and analysed. Initial flow rate measurement campaign conducted in creeks, streams and rivers on and around the plateau for baseline hydrogeological studies. Data collection on fluctuations of groundwater levels in support of EIA hydrogeological model initiated. Surveys on vegetation cover and land use in the areas defined as being directly affected. Fauna survey plan completed and request made to SEMAS for authorization to capture, collect, rescue, transport and release certain fauna. Formal request to SEMAS to expand EIA Terms of Reference to include two additional mineral concessions so that all areas covered by the PAE submitted to the federal mining agency, ANM, can be assessed together.

March 2021 - The first meeting (virtual) with SEMAS Environmental Licensing Coordinator took place to introduce the Project's team and update the Agency on EIA/RIMA development. Monitoring wells drilled and piezometers installed. Wet season avifauna survey campaign. Non-interventive archaeological survey completed. Wet season air/noise/vibration monitoring report completed. Detailed stakeholder mapping socio-political risk and opportunity assessment completed.

April 2021 - Second water sampling campaign conducted. River flow measurement campaign to support the elaboration of the hydrological conceptual model completed. Forest Inventory and first fauna campaign completed. Background water quality report and a memorandum about hydrological information for wet season prepared.

May 2021 - Speleology (caving) survey initiated in the Directed Affected Area (ADA) with a buffer of 250 m. In-person meetings at SEMAS took place in Belém.

June 2021 - Socio-political and stakeholder report completed. Fauna authorization permit received.

July 2021 - Flora and fauna survey teams complete dry season field campaign. Third campaign of measuring flow rates in creeks, streams and rivers on and around the plateau and collecting data on fluctuations of groundwater levels in monitoring wells. Water and soil samples collected in accordance with parameters established by CONAMA. Environmental Sensitivity Map developed using datasets and information about Archaeology, Speleology and Permanent Preservation Areas to give support to PFS studies.

August 2021 - Dry season air/noise/vibration monitoring campaign carried out.

September 2021 - Dry season bird survey campaign completed. Air/noise/vibration report delivered. Work begins on defining project ADA (Direct Affected Area) and the characterization of the project. Background water quality report and memorandum about hydrological information for dry season completed.

Pre-Feasibility Study**20.3 Key Socio-Environmental Considerations**

Hydrology and Hydrogeology Monitoring - Detailed studies to evaluate water resources are in progress in the area. Quantitatively, the evaluation of surface water and groundwater were considered, taking into account the hydrological features. Spring inventories through quarterly water flow measurement campaigns in streams and rivers inside and around the plateau and the fluctuations of groundwater level in monitoring wells were registered during 2021 for collecting data to develop the hydrogeological model.

Water Quality - Evaluation of physiochemical and bacteriological parameters of the study area are being completed. Analytical results for multiple groundwater and surface water monitoring points demonstrate, in general, an environment in which the composition of surface water is mainly controlled by rainfall.

Flora and Fauna – Seasonal baseline studies continue to observe and catalogue incidences of Aquatic Biota, Avifauna, Entomofauna, Flying Mastofauna, Herpetofauna, Ichthyofauna and Mastofauna. Seasonal forest inventories are also being developed.

Soil Chemistry - The regional soil map of the Castelo de Sonhos Project shows the occurrence of Oxisoils and Argissoils under the dense Ombrophilous Submontane vegetation and in areas with occurrence of Litholic Neosol the original vegetation is of Forested Seasonal Savanna (Cerrado), according to the Legal Amazon Vegetation Macro zoning (MMA,2010). Some chemical elements that result by the weathering of minerals of the rocks are largely stored in sediments and soils.

Air Quality, Noise and Vibration – Seasonally conducted baseline air quality monitoring campaigns generated results for total suspended particles (TSP), PM-10 and PM-2.5. Air quality in the Project site can be considered good during wet season and moderate during dry season when compared with standards established by the Brazilian regulatory bodies. Noise campaigns during daytime and night-time were carried out at several points, according to the framework defined by Brazilian National Standards Organization (ABNT NBR) 10151/2019. Environmental vibration level analysis was carried out by means of an engineering seismograph, equipped with a triaxial geophone, which performs the simultaneous measurement of vibration in the three propagation axes (transverse, longitudinal and vertical).

Archaeology - A survey was completed in the project ADA. Analysis of past data near the Curuá River and a field survey through non-intrusive exploration was conducted. Seven areas where lithic and ceramic archaeological vestiges were observed in lowlands near the streams have indicated potential and during a second phase of study, these small areas will be reviewed through soil subsurface verification and heritage education activities with local communities.

Speleology (Caving) - A speleological study was performed, and underground natural cavities were inventoried within the study area and the surrounding areas. Cavities within the study area were registered and photographed. Some caves may be selected for additional detailed studies depending on the definition of the project ADA, although project planning has ensured that no construction or earthmoving activities impact these caves.

Pre-Feasibility Study

Social, Economic and Political - The community that will influence the project includes rural residents of neighbouring properties, Vila de Esperança IV located approximately 12 km away from Castelo de Sonhos Project and 40 km from Castelo de Sonhos District. Analysis of secondary data from official statistical sources and interview information collection with the local population around the project area was carried out. These data were applied in the process of characterizing the area of indirect and regional influence, comprising the municipalities of Altamira and Novo Progresso in Pará and Guarantã do Norte in Mato Grosso.

Questionnaires sent to households and rural establishments in the area directly affected and area of direct influence were tabulated and gave rise to the study database to be considered in the EIA-RIMA. This data base was used to support more detailed stakeholder mapping work to deepen contextual understanding of political, social and economic relations with a focus on opportunities and weaknesses and the construction of a matrix of stakeholders: people, positions, influence, historical interactions, actions and communication channels. In addition, a study was carried out to identify potential weaknesses, challenges and opportunities for engagement, transparency and partnerships. Finally, the preparation of strategic planning, with objectives and tactical actions for intervention and social dialogue were prepared.

Land - The Castelo de Sonhos project is not located in the domain of indigenous lands nor properties of traditional population communities (quilombolas) nor areas of Conservation Units, nor in a military area. Furthermore, the CDS mineral concessions that comprise the ADA of the project do not overlap with any of the areas of interest registered by the National Indian Foundation (FUNAI), Ministry of Environment (MMA), Brazilian Forest Service (SFB), Chico Mendes Institute for Biodiversity Conservation (ICMBIO), National Institute for Colonization and Agrarian Reform (INCRA), or Secretary of Federal Heritage (SPU).

20.4 Closure and Reclamation

Mine closure consists of deactivating mine structures for environmental recovery according to a Plan for the Recovery of Degraded Areas (PRAD) as well as the reintegration of areas for future use. Starting from a conceptual closure plan which contemplates preliminary scenarios and general management measures for the progressive, temporary and final closure; from what is considered in the planning phases based on current knowledge of the project and its associated facilities. In this plan, alternatives for closing each project component will be identified, responding to environmental, mining as well as socio-environmental requirements.

Closure and post-closure monitoring programs will allow for the evaluation of the performance of implemented measures and identification of necessary adjustments. It is important to clarify that the programs are developed at guidelines levels, leaving in any case the possibility of improving them regarding, when the technologies, the regulatory framework and the evolution of the project merit it. Within the closure plan, proposed land use will be disclosed to the community as a result of the studies which were carried out, and the socio-economic dynamics that will govern the signed agreements.

Pre-Feasibility Study**21 CAPITAL AND OPERATING COSTS****21.1 Capital Costs****21.1.1 Basis of Estimate**

The pre-feasibility study was completed by GE21 on behalf of TriStar Gold during the third quarter of 2021, which produced a level 4 capital cost estimate as defined by the American Association of Cost Engineers (AACE) estimate classification system. Any of the estimates does not include any allowances for scope changes, escalation and exchange rate fluctuations.

The capital cost estimate (CAPEX) was developed based on the following premises:

- Database: August 2021.
- Estimate currency: American Dollar (US\$).
- Exchange rate: 1.00 = 5.00 BRL.
- There were three quotes for each package wherever possible. Extreme values were disregarded.
- A contingency factor of 20% was applied

21.1.2 Mining Costs

The CAPEX for mining operations, considers the equipment models presented in Section 16, with the initial cost of operations amounting to US\$ 37.67 M, sustaining capital is US\$ 27.34 M, totalling US\$ 65.01 M (including contingency).

All the selected equipment is manufactured in Brazil and have a wide network of distributors and technical assistance throughout the Brazilian territory.

The Table 21-1 presents the fleet acquisition by year for the Castelo de Sonhos Project.

Pre-Feasibility Study

Table 21-1 Fleet Acquisitions by Year

Equipment	Life (Hours)	Life (Years)	Years						
			1	2	3	4	5	6	
Hydraulic Excavator - 70 t (2.8 – 4.5 m ³)	30,000	6	11	1	1				11
Road Truck 42 t - 8x4	15,000	3	34	9	9	27	5		0
Drilling Machine	25,000	6	11	0	1	0			12
Wheel Loader (3.2 – 7.4 m ³)	30,000	9	1	0					
Bulldozer CAT D8	35,000	10	4	0					
Bulldozer CAT D6	35,000	10	4	0					
Wheel Dozer CAT 834H	30,000	8	2	0	1				
Grader - Caterpillar	35,000	10	3	0					
Operation Support Truck - Scania	15,000	11	3	0					
Water Truck – 20.000 L	18,000	6	4	0					4
Backhoe Excavator	15,000	7	2	0	1				
Hydraulic Excavator - 35 t with Hammer	30,000	10	2	0	1				
Forklift	36,000	35	3	0					
Blasting & Support Truck - Scania	15,000	13	3	0					
Fuel & Lube Truck – 8.000 L	18,000	8	3	0					
Maintenance Support Truck - Munck	20,000	15	3	0					
Crane - 30 t of capacity	36,000	36	1	0					
Portable Lighting Tower	7,000	3	8	1	1	7	1		1
Light Vehicle	6,000	3	6	1	1	6	1		1
Total			108	12	16	40	7		29

Equipment	Years				
	7	8	9	10	11
Hydraulic Excavator - 70 t (2.8 – 4.5 m ³)	1	1			
Road Truck 42 t - 8x4	21	7	2		
Drilling Machine					
Wheel Loader (3.2 – 7.4 m ³)			1		
Bulldozer CAT D8					
Bulldozer CAT D6					
Wheel Dozer CAT 834H		2			
Grader - Caterpillar					
Operation Support Truck - Scania					
Water Truck – 20.000 L					
Backhoe Excavator	2				
Hydraulic Excavator - 35 t with Hammer					
Forklift					
Blasting & Support Truck - Scania					
Fuel & Lube Truck – 8.000 L		3			
Maintenance Support Truck - Munck					
Crane - 30 t of capacity					
Portable Lighting Tower	7	1	1		
Light Vehicle	6	1	1		
Total	37	15	5	0	0

Pre-Feasibility Study

Table 21-2 presents the Initial and Sustaining CAPEX with prices based on GE21 database from several other similar projects in Brazil. Initial Mine CAPEX from the first four years is divided into 30% on year 0 and 70% on year 1. Sustaining capital also includes mine lighting and dewatering allowance for mining operations. On year 10 of operation, an additional US\$ 1.43 million is set aside for fleet maintenance for the final months of operation.

Pre-Feasibility Study

Table 21-2 Initial Mine Fleet and Sustaining CAPEX

CAPEX and Sustaining (US\$'000)			Year											Total	
	US\$'000/Unit	Life (Years)	0	1	2	3	4	5	6	7	8	9	10		11
Hydraulic Excavator -70 t (2.8 - 4.5 m ³)	610	6	-	6,711	610	610	-	-	6,711	610	610	-	-	-	15,862
Road Truck 42 t - 8x4	155	3	-	5,263	1,393	1,393	4,180	774	-	3,251	1,084	310	-	-	17,647
Drilling Machine	320	6	-	3,520	-	320	-	-	3,840	-	-	-	-	-	7,680
Wheel Loader (3.2 – 7.4 m ³)	337	9	-	337	-	-	-	-	-	-	-	337	-	-	673
Bulldozer CAT D8	601	10	-	2,406	-	-	-	-	-	-	-	-	-	-	2,406
Bulldozer CAT D6	337	10	-	1,346	-	-	-	-	-	-	-	-	-	-	1,346
Wheel Dozer CAT 834H	237	8	-	474	-	237	-	-	-	-	474	-	-	-	1,185
Grader - Caterpillar	242	10	-	726	-	-	-	-	-	-	-	-	-	-	726
Operation Support Truck - Scania	109	11	-	327	-	-	-	-	-	-	-	-	-	-	327
Water Truck – 20,000 L	180	6	-	720	-	-	-	-	720	-	-	-	-	-	1,440
Backhoe Excavator	174	7	-	347	-	174	-	-	-	347	-	-	-	-	868
Hydraulic Excavator - 35 t with Hammer	201	10	-	403	-	201	-	-	-	-	-	-	-	-	604
Forklift	60	35	-	180	-	-	-	-	-	-	-	-	-	-	180
Blasting & Support Truck - Scania	109	13	-	327	-	-	-	-	-	-	-	-	-	-	327
Fuel & Lube Truck — 8,000 L	200	8	-	600	-	-	-	-	-	-	600	-	-	-	1,200
Maintenance Support Truck - Munck	136	15	-	409	-	-	-	-	-	-	-	-	-	-	409
Crane - 30 t of capacity	400	36	-	400	-	-	-	-	-	-	-	-	-	-	400
Portable Lighting Tower	45	3	-	360	45	45	315	45	45	315	45	45	-	-	1,260
Light Vehicle	45	3	-	270	45	45	270	45	45	270	45	45	-	-	1,080
Dewatering - Pumps				1,150					540						
Initial CAPEX (US\$'000)			9,418	21,976											31,394
Initial CAPEX w/ contingency			11,302	26,371											37,673
Sustaining CAPEX (US\$'000) (incl. contingency)								4,765	864	11,901	4,793	2,858	736	1,428	27,344

Pre-Feasibility Study

21.1.3 Tailings Facility

21.1.3.1 Tailings Dam Capital Costs

The estimate of the capital costs for the tailings dam is US\$ 14.75 M divided in two phases. The basis for this estimate was the bill of quantities developed by Knight Piésold Consulting which lists the quantities for construction of dam phases – initial dam and raising. The unit rates were then applied in Brazil using appropriate in-country Brazilian costs.

The estimated cost for the initial phase, with taxes, is US\$ 11.56 M (including contingency). The reservoir volume for this phase is 8.77 Mm³.

The estimated cost for the second phase is US\$ 3.19M. The reservoir volume for this phase is 16.39 m³. The total volume of the dam is calculated to be 25.16 Mm³ at 1.55 m³/t dry density.

The Table 21-3 below summarizes these estimates:

Table 21-3: Summary of tailings dam costs

Item	Initial CAPEX (US\$' 000s)	Sustaining (US\$' 000s)	Total (US\$' 000s)
Phase 1	9.63		9.63
Phase 2 (Year 3)		3.19	3.19
Subtotal			12.82
Contingency (20%)	1.93		1.93
Total			14.75

The cost figures presented in this estimate are compatible with those of similar tailings dams in other projects in Brazil.

21.1.4 Processing Plant and Infrastructure

21.1.4.1 Capital Costs – Basis of Estimate

The capital cost estimate includes all the direct and indirect costs along with the appropriate contingencies required to bring the Project into production, as defined by this Study. All equipment and material are assumed to be new.

The execution strategy is based on an engineering, procurement and construction management (EPCM) implementation and horizontal (discipline based) construction contract packaging.

The capital cost estimate has the level of accuracy for an AACE Class 4 estimate that is -15% to -30% on the low side and +20% to +50% on the high side. Contingency is applied at 20%.

Pre-Feasibility Study**21.1.4.2 Direct Quantities**

Direct costs were calculated for main mechanical equipment. The other permanent equipment, materials and labour associated with the physical construction of the site infrastructure, process plant and ancillary facilities were factored according to similar projects.

The equipment material take off list (MTOs) was developed by TriStar for the Castelo de Sonhos Project. Quotations were received for, but not limited to the equipment list.

21.1.4.3 Quotation Requests

For all major equipment, budget quotes were obtained from pre-approved vendors. These quotes were benchmarked against pricing for similar equipment from databases. Pricing for minor equipment was obtained from a general database. An example of the equipment that was quoted is listed below.

- Jaw crusher
- SAG and Ball Mills
- Leach Tanks
- Agitators
- Pumps
- Screens
- Conveyors
- Overhead cranes and hoists
- Air Compressors
- Transmission Line
- Electrowinning cell
- Other

43% of all direct costs and 71% of equipment costs were based on budget proposals.

21.1.4.4 Contractor's Indirect costs

Contractors' indirect costs are part of civil works and cover the costs for mobilization and demobilization of labour, equipment, and contractor facilities to and from the Project site. Other items included in contractor indirect are the establishment of temporary site facilities, utilities for each contractor, maintenance of temporary facilities and equipment, construction management and supervision support, as well as, health and safety facilities, security facilities, environment (HSE) support, site administration support, project expenses (miscellaneous, minor licences and permits) and for contractor's fees and overhead.

Pre-Feasibility Study**21.1.4.5 Engineering, Procurement and Construction Management Services**

The Engineering, Procurement and Construction Management Services (EPCM) costs, required for execution of the Project, includes detailed engineering, drafting, project management and project controls hours and were estimated applying a typical factor over direct costs, defined at 15%.

21.1.4.6 Vendor Commissioning, Start-up and Training

Vendor construction and commissioning attendance costs were estimated by percentage based on similar projects (3% of direct costs) and it includes all vendor representative expenses (flights, catering and accommodation).

21.1.4.7 Spare Parts

The capital cost estimate includes an allowance (5% of direct costs) to cover costs of spare parts for the processing plant.

21.1.4.8 First Fills

The first fills inventory and opening stocks have been considered. These costs consist of reagents and consumable items purchased and stored on site at the onset of operations. First fill and opening stock items include sodium cyanide, quick lime, hydrated lime, activated carbon, hydrochloric acid, sodium metabisulphite, copper sulphate, flocculant, gold room reagents, lubricants and an initial charge of grinding media. This inventory ensures adequate consumables are available for the first stage of operation. Opening stocks have also been allowed for crusher liners, screen panels and SAG mill liners.

This cost was estimated in 1.5% of total supplying equipment costs.

21.1.4.9 Freight

Freight costs inclusive of ex-works packaging and handling, road freight to and from port and sea freight costs from various countries of origin were estimated based historical data. It was assumed a 3% for national supplies and 11.5% for imported items, including insurance for the transportation.

For mobile equipment and some construction bulks sourced in Brazil (earthworks, concrete and field erected tankage) the freight costs were included in the supply costs.

21.1.4.10 Owner's Costs

The considered owner's costs include the necessary consultants for the next phases of the project, such as:

- Risk Analysis
- Project team
- Diligence and inspection
- Technology control

Pre-Feasibility Study

- Project insurance

21.1.4.11 Duties and Taxes

The duties and taxes for the Project are included in the capital costs and were considered in its full amount, without consideration of incentives or taxes reductions.

This estimate contains all local, state and federal taxes and also import duties on a line-item basis.

21.1.4.12 Exclusions

The capital cost estimate is based on the following exclusion and qualifications:

- Cost of bankable feasibility study, financing and interest during construction is excluded.
- Sunk costs are excluded.
- Escalation beyond 3rd quarter of 2021 is excluded.

Pre-Feasibility Study

Table 21-4: Process and Infrastructure Initial Capital Cost Summary

Description	Total Cost (MUS\$)
Offsite General	11.7
Onsite General	1.9
Primary Crushing	4.2
Stockpile & Reclaim	7.8
Grinding	33.8
Leach CIL	21.9
Cyanide Destr / Tailings / Recl . Water	11.8
Strip. Regen. EW	4.8
Reagents	2.0
Maintenance Shops & Warehouse	4.6
Administration Building	1.8
Laboratory	1.5
Security & Safety	1.7
Power Distribution	0.3
Fresh Water Distribution	2.8
Fuel System	0.3
Plant Air	0.2
Distributable Costs (Freight, Equip Usage, Etc.)	3.1
Taxes / Duties - ICMS, PIS, COFINS, ETC	29.9
Total Direct Cost	146.0
Construction Insurance	0.6
Diligence and Inspection	0.4
Consulting	0.3
Soil Survey	2.5
Technology control (for earth works)	0.2
First fills	0.5
Commissioning & Start-up	3.4
Technical Assistance	0.7
Spare parts	2.4
Conceptual Engineering	0.6
Basic Engineering	1.7
As Built	0.3
EPCM - Detailed engineering, procurement and construction management	17.0
Total Indirect Cost	30.4
Contingency	35.3
Total Installed Cost	211.7

21.1.5 Capital Cost Summary

Table 21-5 shows the Level 1 summary of total initial capital costs for the Project. The capital cost for the Castelo de Sonhos Project is estimated to be US\$ 260.9 million expressed in 3rd quarter 2021 price levels inclusive of duties and taxes.

Pre-Feasibility Study

Table 21-5: Initial Capital Cost Summary

Area	Total Cost (MUS\$)
Mine	31.4
Power transmission line	10.4
Plant	166
Tailing storage facility	9.6
Contingency (20%)	43.5
Total Installed Cost	260.9

Table 21-6 shows the Level 1 summary of total sustaining costs for the Project. The total cost spread into all the project lifetime is US\$ 30.53 million expressed in 3rd quarter 2021 price levels inclusive of duties and taxes.

Table 21-6: Sustaining Capital Cost Summary

Description	Annual Costs with Taxes & Contingency (MUS\$)										
	TOTAL	1	2	3	4	5	6	7	8	9	10
Mine Fleet	25.27				4.18	0.77	11.27	4.21	2.77	0.65	1.43
Mine Development	2.07				0.59	0.09	0.63	0.59	0.09	0.09	
Tailings Dam	3.19			3.19							
Total Installed Cost	30.53	0	0	3.19	4.77	0.86	11.9	4.79	2.86	0.74	1.43

21.1.6 QP Opinion

In the QP's opinion the calculations, assumptions and rationale adopted for the CAPEX estimation at the Castelo de Sonhos Project, and their results, are adequate for the purposes used in this technical report.

21.2 Operating Costs

21.2.1 Summary of OPEX

The operating cost includes the mine, process plant, and general and administration (G&A). The life-of-mine overall unit operation cost for the project is US\$27.20 per tonne of plant feed (ROM) as shown in Table 21-7. All costs are in Q3 2021 US dollars.

Pre-Feasibility Study

Table 21-7: Life of Mine Operating Costs

Area	Type of Cost	Unit Cost (US\$/t ROM)
Mining	Labor (incl. contractors)	3.58
	Diesel	2.46
	Consumables	10.07
	Other	0.47
	Total Mining costs	16.58
Processing	Labor	0.88
	Power	1.66
	Consumables (replacement, reagents)	5.79
	Maintenance	0.67
	Total Processing Costs	8.99
G&A	Total G&A costs	1.63
Total	Total costs	27.20

21.2.2 Manpower

The annual required manpower for the operation is summarized in Table 21-8.

Table 21-8 Project Direct Labor

Direct Labor	# Personnel
Plant Operation	59
Plant Maintenance	28
Plant subtotal	87
Mining Operation	80
G&A	33
TOTAL	200

The organization chart and manpower list were estimated based on similar projects. The labor rates include local requirements for social charges, labour law and current practices in the state.

Based on Brazilian labor legislation, it is expected that the employees will be represented by a workers' union, and work schedule and labor rate details will need to be negotiated with the union.

21.2.3 Mining

The operating cost from mining operations during the life-of-mine overall unit operation cost for the project is US\$16.58 per tonne of plant feed (ROM). All costs are in Q3 2021 US dollars.

Table 21-9 presents the hourly costs considered for selected fleet.

Pre-Feasibility Study

Table 21-9 Hourly Costs for Mining Equipment

Equipment	Model	Maint.+WM* -	Maintenance	Wear	Diesel	Total
		OPEX		Material		Cost
		US\$/hr	US\$/hr	US\$/hr	US\$/hr	US\$/hr
Hydraulic Excavator -70 t (2.8 – 4.5 m ³)	Caterpillar	81.50	62.69	18.81	48.00	129.50
Road Truck 42t - 8x4	Scania	26.29	20.70	5.59	18.00	44.29
Drilling Machine	Leopard Di650i	67.17	41.17	26.00	22.00	89.17
Wheel Loader (3.2 – 7.4 m ³)	Caterpillar	41.50	27.98	13.52	16.60	58.10
Bulldozer CAT D8	Caterpillar	76.56	58.75	17.81	43.00	119.56
Bulldozer CAT D6	Caterpillar	33.50	25.71	7.79	33.00	66.50
Wheel Dozer CAT 834H	Caterpillar	33.50	25.71	7.79	33.00	66.50
Grader - Caterpillar	Caterpillar	30.10	23.10	7.00	21.00	51.10
Operation Support Truck - Scania	P360	19.06	15.10	3.96	12.00	31.06
Water Truck – 20,000 L	VOLVO	17.90	13.74	4.16	15.00	32.90
Backhoe Excavator	Caterpillar	56.51	45.24	11.27	13.00	69.51
Hydraulic Excavator - 35 t with Hammer	Komatsu	80.99	63.42	17.57	32.50	113.49
Forklift	Mitsubishi	12.08	11.00	1.08	15.00	27.08
Blasting & Support Truck - Scania	P360	19.06	15.10	3.96	12.00	31.06
Fuel & Lube Truck – 8,000 L	VOLVO	20.70	16.40	4.30	15.00	35.70
Maintenance Support Truck - Munck	Mercedes	17.90	13.74	4.16	15.00	32.90
Crane - 30 t of capacity	Grove	11.09	9.30	1.79	13.00	24.09
Portable Lighting Tower	Patria	12.08	11.00	1.08	8.00	20.08
Light Vehicle	Toyota	17.12	16.87	0.25	8.00	25.12

*Maintenance and wear material

The cost for diesel is US\$1.00 per liter. These prices include works for storage and distribution at the Project. Equipment operating costs consider all maintenance services, parts, components, wear materials (all of which are bound by full-service contracts) and diesel costs.

Contractors and Outsourced Services

An estimated 20% of labor costs are considered for the costs of outsourced services. Among the outsourced services are:

- Meals costs
- Auxiliary cleaning services for offices, equipment and road signs
- Mining auxiliaries, property guards and receptionists
- Workforce transportation to site and home
- IT services and software
- Legal support – lawyer's office
- Mining consultants

Pre-Feasibility Study

- Office supplies.

Environmental, Geotechnical and Dewatering

An estimated annual cost of US\$ 1.5 M is applied for environmental expenses and US\$ 0.14 M for site dewatering and geotechnical works.

The Project site wide water management study was developed by Piteau Associates UK LTD., and the geotechnical studies developed by Itaaçu Ltda. The estimated works include:

- Topsoil removal and proper storage
- Rehabilitation of areas mined to the final pit and surroundings
- Open pits water pumping and channeling
- Surface water management
- Geotechnical surveys, control and any necessary reinforcement
- Dam monitoring and emergency alarm system.

The Table 21-10 present the summary of all operating mining costs.

Pre-Feasibility Study

Table 21-10 Summary of Mining Operating Costs

Mining OPEX	Year											Total
	1	2	3	4	5	6	7	8	9	10	11	
Equipment Total - US\$ x 1,000	25,458	28,499	31,792	31,001	29,749	21,325	17,380	17,358	18,496	18,749	16,735	256,541
Equipment Maintenance	12,083	13,512	15,096	14,728	14,102	10,126	8,221	8,205	8,742	8,861	7,908	121,584
Equipment Wear Material & Tires	3,998	4,439	4,877	4,793	4,634	3,304	2,665	2,620	2,796	2,834	2,517	39,478
Diesel	9,377	10,547	11,819	11,479	11,014	7,895	6,493	6,532	6,958	7,055	6,309	95,480
Explosives - US\$ x 1,000	25,363	27,392	27,917	28,470	28,580	19,454	15,471	14,076	15,156	15,330	13,099	230,310
Explosives - Ore	2,272	2,399	2,445	2,195	2,416	2,434	2,367	2,433	2,304	2,420	2,143	25,829
Explosives - Waste	23,090	24,993	25,472	26,275	26,164	17,020	13,104	11,643	12,852	12,910	10,956	204,481
Workforce Total - US\$ x 1,000	10,714	11,606	12,697	12,334	11,933	9,544	8,883	8,975	9,270	9,344	8,828	114,128
Workforce Management	3,558	3,558	3,558	3,558	3,558	3,558	3,558	3,558	3,558	3,558	3,558	39,133
Workforce - Operation	4,913	5,547	6,254	6,001	5,747	4,115	3,644	3,735	3,934	4,006	3,626	51,522
Workforce - Maintenance	1,410	1,576	1,834	1,761	1,667	1,182	1,065	1,066	1,108	1,109	1,029	14,807
Workforce - Absenteeism + Vacation Team	834	925	1,051	1,015	961	689	616	616	671	671	616	8,666
Contractors Costs (20% Workforce) - US\$ x 1,000	2,143	2,321	2,539	2,467	2,387	1,909	1,777	1,795	1,854	1,869	1,766	22,826
Envirom. & Geotech. & Dewat. Costs - US\$ x 1,000	1,644	1,644	1,644	1,644	1,644	1,644	1,644	1,644	1,644	1,644	1,644	18,084
Environmental and Rehabilitation	1,500	1,500	1,500	1,500	1,500	1,500	1,500	1,500	1,500	1,500	1,500	16,500
Dewatering & Geotech.	144	144	144	144	144	144	144	144	144	144	144	1,584
Total Mining Costs - OPEX - US\$ x 1,000	65,321	71,462	76,590	75,916	74,293	53,875	45,154	43,848	46,420	46,936	42,072	641,888

Pre-Feasibility Study

21.2.4 Processing

The operating cost for the process plant and related infrastructure at the Project site is based on the estimated direct costs for processing at a nominal annual throughput of 3.65 Mt of ROM. The plant availability is assumed to be 95%, which incorporates both scheduled and unscheduled maintenance.

The process plant operating costs include manpower, reagents & consumables, power required for the process, and operational maintenance. The process plant and related infrastructure annual operating cost is estimated to be US\$ 32.83 M, equivalent to US\$ 8.99/t of plant feed. The details are summarized in Table 21-11.

Table 21-11: Process Plant Operating Cost

Type of Cost	ROM US\$/t	Avg. Cost US\$ M/y
Manpower	\$0.88	3.20
Power	\$1.66	6.07
Consumables	\$5.79	21.12
Maintenance	\$0.67	2.44
Total Processing Costs	\$8.99	32.83

21.2.4.1 Power

Power consumption estimates have been adopted from the electrical load analysis. The total estimated power consumption per annum is 111.3 MWh. Power supply costs were based on the ANEEL (National Agency of Electrical Energy) and the power market for the free consumer plus 25% ICMS for a total price of US\$0.07 kW/h. PIS/COFINS recoverable taxes are excluded from this figure.

Pre-Feasibility Study

21.2.4.2 Reagents and Consumables

The estimated annual reagent and consumables cost, including the freight, is US\$ 21.12 M, equivalent to US\$ 5.79/t of plant feed. The unit prices for supplies and consumables used in the operating cost estimate were provided by various potential suppliers completed during the pre-feasibility study based on Q3 2021.

The reagents and consumables costs for the process plant are summarized in Table 21-12.

Table 21-12: Process Plant Reagents and Consumables Costs

Category	Description	Total Cost (US\$ M/y)	Unit Cost (US\$/t ROM)
Process Consumables	Crusher Liners	0.56	0.15
	Mill Liners	2.31	0.63
	Grinding Media	9.28	2.54
Reagents	Calculated based on quantities and quotes	8.98	2.46
Total	Total Costs	21.12	5.79

21.2.4.3 Maintenance

The estimated annual maintenance cost is US\$ 2.44 M, equivalent to US\$ 0.67/t of plant feed. Process maintenance was factored assuming 5% of the direct mechanical and electrical equipment. The tax estimates on maintenance repair parts are split depending on whether they are sourced nationally (Brazil) or imported.

21.2.5 General and Administration

Operating costs for General and Administration (G&A) include items that are not captured in the mine or the process costs. These costs include items such as management and administration personnel labor, environmental monitoring, safety, medical, catering expenses, travel expenses, communications, shared equipment, emergency response, site-wide maintenance, insurance, legal fees, property taxes, as well as other miscellaneous office expenses.

The annual G&A costs are estimated annually at US\$ 5.74 M equivalent to US\$ 1.63/t of plant feed, as shown in Table 21-13.

Table 21-13: General and Administration

Description	Total Cost (US\$ M/y)	Unit Cost (US\$/t ROM)
Staff Labor	2.39	0.68
Power	0.58	0.17
General Expenses	2.01	0.57
Spares	0.76	0.22
Total Cost	5.74	1.63

Pre-Feasibility Study

22 ECONOMICAL ANALYSIS**22.1 Taxes****22.1.1 List of relevant taxes**

- FEDERAL TAXES
 - II: Import tax
 - IPI: Tax on manufactured products.
 - IRPJ: Income tax.
 - CSLL: Social Contribution on net income.
 - COFINS: Contribution for social security financing.
 - PIS: Contribution to the social integration plan.
 - CFEM: Financial compensation for mineral resources exploration.
- STATE LEVEL
 - ICMS: Tax on circulation of goods and services for interstate and intercity transportation and communication.
- MUNICIPAL LEVEL
 - ISSQN: Taxes upon services of any kind.

22.1.2 Tax regime

Income tax (IRPJ) was calculated according to Federal Law nº 9.430, from December 27th of 1996 rules.

Social Contribution (CSLL) was calculated according to Federal Law nº 7.689, from December 15th of 1988

Non-cumulative PIS was calculated according to Federal Law nº 10.637, from December 30th of 2020

Non-cumulative COFINS was calculated according to Federal Law nº 10.833, from December 29th of 2003

22.2 Fiscal Benefits at Federal Level**22.2.1 SUDAM – Income Tax Benefit (Government Grant)**

The Brazilian subsidiary is subject to corporate income tax rate of 25% which is applied to pre-tax profit. The company can apply to the Government Grant (tax incentive) granted by SUDAM (Superintendência do Desenvolvimento da Amazônia) based on Federal Law Nº 13,799 of January 3rd, 2019, in order to be able to reduce 75% of the income tax rate as tax incentive in a 10-year period from the year in which the Appraisal Certificate from SUDAM is issued.

Pre-Feasibility Study**22.2.2 Social Contribution**

The social contribution tax is 9% calculated based on net profit.

22.2.3 Refundable Tax

PIS and COFINS were offset against Federal Taxes based on PIS and COFINS non-cumulative rules.

22.3 Royalties**22.3.1 Royalty payable to the Federal Government – CFEM**

CFEM stands for Financial Compensation for Mineral Resources Exploration, the royalty rate for gold is currently 1.5% arising from the sale of the mineral product, less the sales taxes of the mineral product, transportation and insurance costs.

22.3.2 Private Royalties (NSR)

- Royalty to original vendor:

2% of the mineral production produced in the mineral right to be calculated based on Net Smelt Return (NSR).

- Royalty to Royal Gold:

1.5% of NSR is payable.

22.4 Depreciation

Depreciation of plant infrastructure and equipment was calculated in a simplified way, depreciating the investment in annual values over the mine life.

The Income Tax legislation allows for eventual tax losses calculated in previous periods to be offset against the profits subsequently calculated from the legal entity taxed by the Real Profit. The compensation for such losses is limited to 20% of the actual profit before compensation.

A Discounted Cash Flow (DCF), base case scenario was developed to assess the project based on economic-financial parameters, on the results of the mine scheduling and on the sustaining CAPEX and OPEX estimate.

The parameters used to develop this DCF are presented in Table 22-1.

Pre-Feasibility Study

Table 22-1 Selling Prices and Taxes

Selling Prices and Taxes	
Selling price	
Product	Sell Price (US\$/oz)
Product Au/oz	US\$ 1,550
Taxes	
CFEM	1.5%
INCOME TAX*	25.0%
CSLL	9.0%
Financial Parameters	
Discounted Rate	5.0% aa
NPV	Beginning of year
Royalties	
Surface Royalties	based on subsection 22.3

*Discount related to SUDAM tax benefit.

The Project is estimated to have a post-tax net present value of \$ 321 million, at a discount rate of 5% per year and an IRR of 28.0%. Table 22-2 presents the operating income statement and Table 22-3 present the Discounted Cash Flow (DCF) results. Table 22-4 presents a summary of the key metrics from the economic analysis.

Table 22-2 Operating income statement

OPERATING INCOME STATEMENT (US\$'000')

Description	Year - 2	Year -1	Year 1	Year 2	Year 3	Year 4	Year 5	Year 6	Year 7	Year 8	Year 9	Year 10	Year 11
Plant Feed - Ton x 1000	0	0	3,406	3,596	3,665	3,291	3,622	3,649	3,548	3,648	3,454	3,627	3,213
Au recovered by period - Oz	0	0	152,402	147,282	146,658	148,277	147,222	133,362	114,035	79,306	85,973	94,862	83,003
Gross Revenue	0	0	236,223	228,286	227,320	229,830	228,195	206,711	176,755	122,924	133,258	147,037	128,655
Deductions from Operating Revenue	0	0	0	0	0	0	0	0	0	0	0	0	0
Net Operating Revenue	0	0	236,223	228,286	227,320	229,830	228,195	206,711	176,755	122,924	133,258	147,037	128,655
Cash Cost	0	0	(96,071)	(103,905)	(109,676)	(105,635)	(106,990)	(86,770)	(77,142)	(76,716)	(77,199)	(79,269)	(70,741)
Freight / Refining	0	0	(1,981)	(1,915)	(1,907)	(1,928)	(1,914)	(1,734)	(1,482)	(1,031)	(1,118)	(1,233)	(1,079)
Depreciation and Exhaustion	0	0	(28,103)	(28,103)	(28,103)	(18,276)	(19,229)	(19,402)	(21,252)	(21,258)	(21,656)	(19,316)	(1,004)
Gross Profit	0	0	110,068	94,364	87,634	103,991	100,062	98,806	76,878	23,919	33,285	47,218	55,831
<i>Gross margin (without depreciation)</i>	<i>0.0%</i>	<i>0.0%</i>	<i>46.6%</i>	<i>41.3%</i>	<i>38.6%</i>	<i>45.2%</i>	<i>43.8%</i>	<i>47.8%</i>	<i>43.5%</i>	<i>19.5%</i>	<i>25.0%</i>	<i>32.1%</i>	<i>43.4%</i>
SG&A	0	0	(5,744)	(5,744)	(5,744)	(5,744)	(5,744)	(5,744)	(5,744)	(5,744)	(5,744)	(5,744)	(5,744)
SG&A - Depreciation	0	0	0	0	0	0	0	0	0	0	0	0	0
<i>SG & A / Net Revenue</i>	<i>0.0%</i>	<i>0.0%</i>	<i>2.4%</i>	<i>2.5%</i>	<i>2.5%</i>	<i>2.5%</i>	<i>2.5%</i>	<i>2.8%</i>	<i>3.2%</i>	<i>4.7%</i>	<i>4.3%</i>	<i>3.9%</i>	<i>4.5%</i>
CFEM	0	0	(3,543)	(3,424)	(3,410)	(3,447)	(3,423)	(3,101)	(2,651)	(1,844)	(1,999)	(2,206)	(1,930)
Royalties	0	0	(7,493)	(7,325)	(7,338)	(7,313)	(7,283)	(6,545)	(5,654)	(4,147)	(4,442)	(4,825)	(4,127)
Income before Income Tax / Social Contribution	0	0	93,287	77,870	71,143	87,487	83,612	83,416	62,829	12,185	21,100	34,444	44,030
Income Tax	0	0	(13,993)	(11,681)	(10,671)	(13,123)	(12,542)	(12,512)	(9,424)	(1,828)	(3,165)	(5,167)	(6,605)
Income Tax (above R\$ 60 thousand in the quarter)	0	0	(9,324)	(7,782)	(7,109)	(8,744)	(8,356)	(8,337)	(6,278)	(1,214)	(2,105)	(3,440)	(4,398)
Income Tax - Benefit	0	0	17,491	14,601	13,339	16,404	15,677	15,640	11,780	2,285	3,956	6,458	0
Social Contribution	0	0	(8,396)	(7,008)	(6,403)	(7,874)	(7,525)	(7,507)	(5,655)	(1,097)	(1,899)	(3,100)	(3,963)
Net Income	0	0	79,066	66,000	60,298	74,150	70,866	70,700	53,252	10,331	17,887	29,196	29,065
Net Margin	0.0%	0.0%	33.5%	28.9%	26.5%	32.3%	31.1%	34.2%	30.1%	8.4%	13.4%	19.9%	22.6%
EBITDA	0	0	121,390	105,973	99,246	105,763	102,841	102,818	84,081	33,443	42,757	53,760	45,034
EBITDA margin	0.0%	0.0%	51.4%	46.4%	43.7%	46.0%	45.1%	49.7%	47.6%	27.2%	32.1%	36.6%	35.0%
Income Tax			-6.24%	-6.24%	-6.24%	-6.24%	-6.24%	-6.24%	-6.24%	-6.21%	-6.23%	-6.24%	-24.99%

Table 22-3 Project cash flow

PROJECT CASH FLOW (US\$'000') - Without Leverage													
Description	Year - 2	Year -1	Year 1	Year 2	Year 3	Year 4	Year 5	Year 6	Year 7	Year 8	Year 9	Year 10	Year 11
EBIT	0	0	93,287	77,870	71,143	87,487	83,612	83,416	62,829	12,185	21,100	34,444	44,030
(+) Depreciation	0	0	28,103	28,103	28,103	18,276	19,229	19,402	21,252	21,258	21,656	19,316	1,004
(=) EBITDA	0	0	121,390	105,973	99,246	105,763	102,841	102,818	84,081	33,443	42,757	53,760	45,034
(-) CAPEX	(78,267)	(182,622)	0	0	(3,190)	(4,765)	(864)	(12,441)	(4,793)	(2,858)	(736)	(1,428)	0
(+/-) Working Capital Variation	0	0	(14,012)	(560)	(498)	374	(98)	2,177	1,371	978	(226)	(412)	10,904
(-) First Installment (João Américo)	(1,500)	0	0	0	0	0	0	0	0	0	0	0	0
(-) Mine Closure Cost	0	0	0	0	0	0	0	0	0	0	0	0	(5,000)
(+) Salvage Value	0	0	0	0	0	0	0	953	173	2,380	959	572	14,552
(-) Income Tax / Social Contribution	0	0	(14,222)	(11,870)	(10,844)	(13,337)	(12,746)	(12,716)	(9,577)	(1,853)	(3,213)	(5,248)	(14,965)
(+) CAPEX Tax Recovery	0	0	4,093	4,093	4,093	4,093	0	0	0	0	0	0	0
(=) Free Cash Flow to Firm (FCFF)	(79,767)	(182,622)	97,250	97,636	88,807	92,128	89,134	80,791	71,255	32,090	39,540	47,243	50,525
(=) Accumulated Free Cash Flow to Firm	(79,767)	(262,389)	(165,139)	(67,503)	21,304	113,432	202,565	283,356	354,611	386,701	426,242	473,485	524,010
CAPEX flow	(78,267)	(182,622)	0	0	(3,190)	(4,765)	(864)	(12,441)	(4,793)	(2,858)	(736)	(1,428)	0
Operational flow	(1,500)	0	97,250	97,636	91,996	96,893	89,998	93,232	76,048	34,948	40,276	48,671	50,525
Free Cash Flow (without taxes)	(79,767)	(182,622)	111,472	109,506	99,651	105,465	101,880	93,507	80,832	33,943	42,753	52,491	65,491
Accumulated Free Cash Flow (without taxes)	(79,767)	(262,389)	(150,917)	(4,411)	58,240	163,705	265,585	359,092	439,923	473,867	516,620	569,111	634,602

Pre-Feasibility Study

Table 22-4 Economical Analysis Summary

DISCOUNT RATE	%	5.00%
POST-TAX		
NET PRESENT VALUE - NPV	US\$ x 1000	321.0
PROJECT IRR	%	28.0%
SIMPLE PAYBACK (after start-up)	Years	2.8
PRETAX		
NET PRESENT VALUE - NPV (Pre-tax)	US\$ x 1000	399.1
PROJECT IRR (Pre-tax)	%	32.7%
SIMPLE PAYBACK (after start-up)	Years	2.4

22.5 Sensitivity Analysis

A sensitivity analysis was undertaken to evaluate the impact of the resulting economic indicators for the following attributes, within the cash flow:

- Discount Rate;
- Sell price
- OPEX
- CAPEX
- Exchange rate

The WACC, OPEX, NPV, was evaluated by varying its value from -20% to +20%, Figure 22-1 shows the sensitivity analysis developed by GE21.

Pre-Feasibility Study

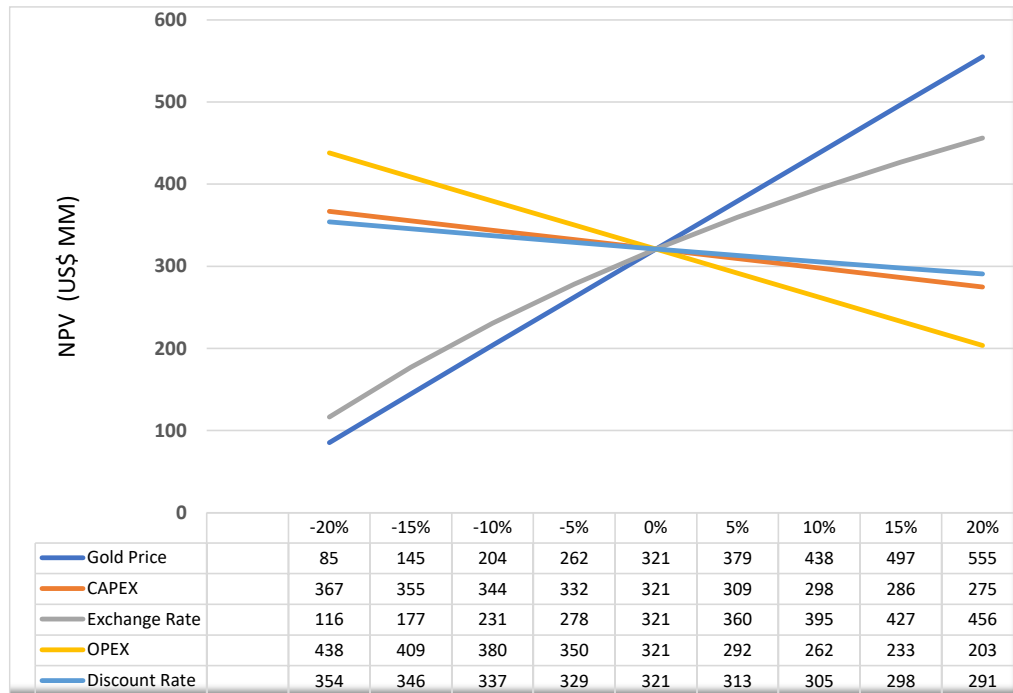

Figure 22-1 Sensitivity analysis

Pre-Feasibility Study**23 ADJACENT PROPERTIES**

There are no properties immediately adjacent to the Castelo de Sonhos Project. Regionally the Palito Mine Complex, that belongs to Serabi Gold PLC, is approximately 300km from Castelo de Sonhos Project and produces about 40,000 /oz per annum.

Pre-Feasibility Study

24 OTHER RELEVANT DATA INFORMATION

All relevant data known to the Qualified Persons are reported in the appropriate Sections. No other relevant data information must be disclosed.

Pre-Feasibility Study**25 INTERPRETATION AND CONCLUSIONS**

This PFS is based on a combination of geological, geotechnical and metallurgical studies which, taken together, establish that gold production from Castelo de Sonhos is both technically and economically feasible.

GE21 received a resource model for the Castelo de Sonhos project from TriStar and independently assessed, validated and revised it to be used in the reserves estimate provided in this document. The new, current resource block model has most of the resource in the confidence level of Indicated category. The QP. Leonardo de Moraes Soares considered the MIK method performed by CDS acceptable for application in the Mineral Resources Estimate.

The mine planning model adopted was considered as a “diluted” model, adding approximately 3.9% mass dilution and 4.5% grade dilution to the source model. GE21 developed appropriate parameters for pit optimization, in order to generate nested optimized pits that were then used a basis for interim and ultimate design pit.

The CDS processing plant will be fed with 3.65Mt of ROM/year with a gold production of 146 koz/year in Phase 1 (Years 1 through 6) and 91 koz/year in Phase 2 (Years 7 through 11).

Whole ore agitation leaching has been selected as the preferred process flowsheet for project development. The plant will include crushing, grinding, hybrid cyanidation and carbon in leach, carbon acid wash, pressure stripping, and thermal regeneration. Gold will be electrowon from loaded eluate. Metal deposited on stainless steel wool cathodes will be rinsed off, decanted and collected as “sludge” which will be dried and smelted to produce doré bars for shipment to third party refiners.

A Discounted Cash Flow scenario was developed to assess the project based on economic-financial parameters, on the results of the mine scheduling and on the Sustaining CAPEX and OPEX estimate.

The project estimates an NPV_(5%) for CDS of \$321million.

Pre-Feasibility Study**26 RECOMMENDATIONS**

GE21 recommends advancing the project to a feasibility study, which should consider the following recommendations:

- Perform a confirmatory campaign of density test work to improve the density of information across the deposit, including in the friable upper arenite that will account for much of the stripping along the high walls of the open pits.
- Continue to expand the total mineral resource with:
 - holes that extend current resources into adjacent areas where the deposits remain open along strike and down-dip.
 - holes that test resource potential in the interior of the plateau, particularly at depths beyond the reach of open-pit operations.
 - holes that infill 100 m drilling to improve the classification of resources from Inferred to Indicated.
 - perform a study based on a local reduction of drilling grid size and update on geostatistical modelling to improve the classification of resources from Indicated to Measured.
- Calculate the moisture and blasted swell effect analyses for ore and waste.
- Refine a grade control program.
- Detail Geotechnical analysis including a geotechnical oriented diamond drilling campaign and logging, including sampling collecting for tensile, compressive and shear strength tests.
- Perform supplementary geotechnical investigations of planned infrastructure sites including at waste pile areas; supplementary geochemical tests (ARD); large-scale waste rock and tailings co-disposal stockpile field test.
- To implement the hydrological and hydrogeological studies for the next phases of the project.
- To conduct a quotation for mining equipment including a full services contract for corrective and preventive maintenance services, including the supply of parts. Caterpillar, Komatsu, Liebherr, Mercedes, Volvo and Scania suppliers could be asked to submit proposals.

An estimate for the costs of the recommended items is shown below:

- Swell effect analysis tests at an estimated cost of US\$ 20,000.
- 1000 test works for density determination at an estimated cost of US\$ 20,000.
- Hydrological and hydrogeological studies at an estimated cost of US\$ 300,000.

Pre-Feasibility Study

- 38,000 meters of a new drilling campaign for the improvement of geological and grade estimate at an estimated cost of US\$ 4,600,000.
- Prepare a Feasibility Study at an estimated cost of US\$ 800,000.

Pre-Feasibility Study**27 REFERENCES**

- Alkmin, F.F. (2011), "Stratigraphy and structure of the Castelo dos Sonhos gold mineralization host rocks, southern Pará: Brazil", TriStar Gold Internal Report.
- CIM (2014), "Definition Standards on Mineral Resources and Mineral Reserves".
- CSA Global Canada Geosciences Ltd (2017), "Mineral resource estimate update on the Castelo de Sonhos gold project Pará State, Brazil", TriStar Gold National Instrument 43-101 Technical Report.
- Ebrahimi, A. (2013), "The Importance of Dilution Factor for Open Pit Mining Projects".
- Eglinton, B. (2015), "Supercontinent Cyclicality: Relevant Data, Constraints, Limitations and Aspects Requiring Particular Attention", Paper invited for presentation at the Fall 2015 meeting of the American Geophysical Union.
- Frimmel, H.E. (2005), "The case for a modified paleo-placer model for Witwatersrand gold", in SEG Newsletter, No. 60, p. 7-14.
- Frimmel, H. E. (2014), "A giant Mesoarchean crustal gold-enrichment episode: Possible causes and consequences for exploration", in Society of Economic Geologist Special Publication 18, p. 209-234.
- GE21 Consultoria Ltda (2018) "Castelo de Sonhos Gold Project, Pará State, Brazil, Independent Technical Report – Preliminary Economic Assessment", TriStar Gold National Instrument 43-101 Technical Report.
- Girard, R (2020), "Gold Grains Counting and Grade Estimation from RC Drilling Samples Using ARTGold™ Technology", Castelo de Sonhos, Brazil, 2020.
- Goovaerts, P. (1997) Geostatistics for Natural Resources Evaluation. Oxford University Press, New York.
- Karpeta, W.P. (2016), "The Geology of the Castelo de Sonhos Project, Pará, Brazil: An Initial Assessment", TriStar Gold Internal Report.
- Klein, E.L., Rodrigues, J.B., Queiroz, J.D.S., Roberto G. Oliveira, R.G., Guimarães, S.B. and Chaves, C.L. (2017), "Deposition and tectonic setting of the Palaeoproterozoic Castelo dos Sonhos metasedimentary formation, Tapajós Gold Province, Amazonian Craton, Brazil: age and isotopic constraints", International Geology Review, Volume 59, p.864-883.
- Koster E.H and Steel R. J. (1984), Sedimentology of gravels and conglomerates (pp.1-31) Chapter: Alluvial and coastal conglomerates: their significant features and some comments on gravelly mass-flow deposits Publisher: Canadian Society of Petroleum Geologists Memoir 10.

Pre-Feasibility Study

- Kroese, D.P., Brereton, T., Taimre, T. and Botev, Z. (2014), “Why the Monte Carlo method is so important today”, *Wiley Interdisciplinary Reviews: Computational Statistics*, (doi:10.1002/wics.1314)
- Lipson, R. (2016), “Castelo de Sonhos Geological Field Work”, TriStar Gold Internal Report.
- Mario E. Rossi, Clayton V. Deutsch (2013), “Mineral Resource Estimation”, Springer Science & Business Media, p. 152155.
- McGowan, J.H. and Groat, C.G. (1971) Van Horn Sandstone, West Texas: an alluvial fan model for mineral exploration. Texas Bureau Economic Geology Report No. 72, 57p.
- McPartland, J.S. (2017), “Preliminary Metallurgical and Comminution Testing – Castelo de Sonhos Drill Core Composites – MLI Job No. 4160”, McClelland Laboratories Inc.
- McPartland, J.S. (2020), “Report on Whole Ore Milling/Cyanidation Testing – MLI Job No. 4567”, McClelland Laboratories Inc.
- Mello, R. (2014), “Mineral Resources Estimation for the Castelo de Sonhos Project, Pará State - Brazil”, TriStar Gold National Instrument 43-101 Technical Report.
- *Mineral resource and ore reserve estimation, the AusIMM guide to good practice*. 2nd edition, Monograph 30. The Australasian Institute of Mining and Metallurgy, 2014.
- Queiroz, J.D.S. (2015), “Aspectos geológicos e metalogenéticos do depósito de ouro hospedado em metaconglomerados e metarenitos paleoproterozoicos Castelo de Sonhos, Província Tapajós, sudoeste do Pará”, MSc thesis, Universidade Federal do Pará - Belém.
- RBM Consultoria (2014), “Caracterizacao Tecnologica Em Uma Amostra De Minerio De Ouro”.
- Rossi, M.E., and Camacho, J.E. (2004) “Application of Geostatistical Conditional Simulations to Assess Resource Classification Schemes”, *CIM Bulletin*, v. 97, n. 1079.
- Srivastava, M. (2018), “Leachwell, Fire Assay and Metallic Screen Assays”, TriStar Internal Report.
- Srivastava, M. (2017), “Variability in Duplicates”, TriStar Internal Report.
- SRK, (2004), “An Independent Technical Report on the Tarkwa Gold Mine, Ghana”, National Instrument 43-101 Technical Report prepared for Gold Fields Limited and IAMGold Corporation.
- White, A. J. R., Robb, V. M., Robb, L. J. and Waters, D. J. (2010). “Portable Infrared Spectroscopy as a Tool for the Exploration of Gold Deposits in Tropical Terrains: A Case Study at the Damang Deposit, Ghana” in SEG Special Publication 15, p. 67-84.

Pre-Feasibility Study

- Froidevaux, R. (1992) “P-field simulation”, in Soares, A. (eds) *Geostatistics Troia, Quantitative Geology and Geostatistics*, v. 5, Springer, Dordrecht, (doi. 10.1007/978-94-011-1739-5_7)
- Rodriguez, P.C., Srivastava, M. (2021), “Mineral Resource Update for the Castelo de Sonhos Gold Project, Pará State, Brazil”, TriStar Gold National Instrument 43-101 Technical Report.
- TriStar Gold (2016), Exploration Target Range for the Castelo de Sonhos Gold Project, Pará State, Brazil, National Instrument 43-101 Technical Report filed on SEDAR.
- Verly, G., and Parker, H.M. (2021) “Conditional Simulation for Mineral Resource Classification and Mining Dilution Assessment from the Early 1990s to Now”, *Mathematical Geosciences*, v. 53, p. 279-300.